

SECTION 27 00 00 – COMMUNICATIONS

PART 1 - GENERAL

1.1 DESCRIPTION

- A. This document contains the General and Supplementary Conditions that are a part of the requirements for the work under this Division of the Specifications to install Telecommunications Systems and Components.
- B. The term "Telecommunications Systems and Components" are understood to include TELEPHONE, DATA, CATV systems/components and Radio (RF) systems and components when such systems and/or components are part of the Cal Poly Campus Project.
- C. The content in the Division 27 specification is based on national standards and guidelines for telecommunications systems, including those developed by the California State University Telecommunications Infrastructure Planning Standards (TIP), the Electronic Industry Association (EIA), Telecommunications Industry Association (TIA), Institute of Electrical and Electronic Engineers (IEEE) and Building Industry Consulting Services International (BICSI). Great emphasis is placed herein on the idea that taking guidance from such sources is generally more desirable than using specific manufacturer's proprietary designs which may quickly become outdated or may be incompatible with other needed equipment.
- D. To better clarify guidance, should a conflict between documents arise, the order of precedence shall be as follows:
 - 1. Cal Poly ITS, University Telecommunications Infrastructure Planning (UTIP) Standards
 - 2. This Division 27 specification
 - 3. CSU's "Telecommunications Infrastructure Planning Standards" document (TIP)
 - 4. Electronic Industry Association (EIA), Telecommunications Industry Association (TIA), Institute of Electrical and Electronic Engineers (IEEE)
 - 5. Building Industry Consulting Services International (BICSI)
- E. The precedence can be overridden in the case where an item is disallowed by an applicable building code and/or with the approval in writing of the Cal Poly

Designated Telecommunications Representative.

F. Referenced Individuals in this Document

1. Following is a list of the individuals referenced in this document
 - a. University: California Polytechnic State University
 - b. Design team: The facility planners, architects, consultants, information technology managers, or designers who are working on this project to develop the telecommunications design, drawings, and specifications.
 - c. Cal Poly Facilities Project Manager: The project manager who is assigned to this project by the Cal Poly Facilities Management and Development Department.
 - d. Contractor: The general contractor and all subcontractors working for the general contractor on this project.
 - e. Cal Poly ITS Telecom Group: The Cal Poly Information Technology Services department that will oversee all aspects of the telecommunications infrastructure included in this project.
 - f. Cal Poly Designated Telecommunications Representative: The individual that is assigned by the Cal Poly ITS Telecom Group to oversee and approve all aspects of this project. This is the only authorized person who can approve the Contractor's work. Approvals by another person is not allowed without written consent by the Cal Poly Designated Telecommunications Representative or written replacement of the Cal Poly Designated Telecommunications Representative by the Cal Poly ITS Telecom Group.

1.2 INTERDISCIPLINARY INFRASTRUCTURE

- A. Comments regarding infrastructure installed by other Specification sections:
1. The Division 27 specification includes comments and requirements for infrastructure that would be installed by contractors installing other Division Specification sections.
 2. The success of the Division 27 installation depends on infrastructure installed by other Specification sections such as grounding rods, grounding connection to building steel, MDF, IDF, or SDF room construction, electrical in rooms, low voltage pathways, etc.
 3. If the Division 27 Contractor identifies infrastructure that was not designed and installed as shown in this Division 27 specification, the Division 27 Contractor should contact the Cal Poly Designated Telecommunications Representative immediately.
 4. Division 27 cabling or equipment should not be installed within infrastructure that was not installed as described in this Division 27 specification without the express written consent of the Cal Poly Designated Telecommunications

Representative.

5. Other Division contractors installing low-voltage cable and infrastructure as part of their systems shall follow DIV 27 specifications, such as lighting, building management systems, etc.
- B. Interdisciplinary infrastructure to be included in the Division 27:
1. Division 27 drawings should show all low voltage cabling needed for data cabling, even the data cabling needed for other systems shown in other Specification sections such as security cameras, AV systems, card access panels, mechanical systems, etc.
 2. Whether shown in the Division 27 drawings or not, it is the responsibility of the Division 27 Contractor to confirm that the low voltage cabling needed for those other interdisciplinary systems has been included in the Division 27 scope of work.

1.3 QUALITY ASSURANCE

- A. Comply with the current applicable codes, ordinances, and regulations of the authority or authorities having jurisdiction, the rules, regulations, and requirements of the utility companies serving the project and the Universities insurance underwriter.
- B. Drawings, specifications, codes, and standards are minimum requirements. Where requirements differ, the most stringent apply.
- C. All equipment and installations shall meet or exceed minimum requirements of ADA, ANSI, ASTM, IEEE, TIP, NEC, NEMA, NFPA, OSHA, UL, and the State Fire Marshall.
- D. Contractors shall use the strictest manufacturer written recommendations, specifications, and the Cal Poly ITS, University Telecommunications Infrastructure Planning (UTIP) Standards Document.
- E. Should any change in drawings or specifications be required to comply with governing regulations, notify and receive written approval from the Cal Poly Designated Telecommunications Representative prior to submitting your bid.
- F. Execute work in strict accordance with the best practices of the trades in a thorough, substantial, workmanlike manner by competent workmen. Provide a competent, experienced, full-time Superintendent and Project Manager who are authorized to make decisions on behalf of the Contractor.
- G. All telecommunications technicians must have a manufacturer's certification for the Structured Cable System (SCS) components that they are installing as part of the Telecommunications Systems and Components or they must have an applicable BICSI certification.
- H. Provide all components of a complete system specified within all project documents, specifications, and drawings.

- I. All unused component parts from all system installations shall be delivered to the Cal Poly Designated Telecommunications Representative and shall not be disposed of or thrown away.

1.4 CODES, STANDARDS, AND GUIDELINES

- A. The references to the following codes and standards are meant to represent the most current and up-to-date revisions or printing as of the issue of this document. The Contractor is responsible for following the latest revision or printing (UON).
- B. ANSI/TIA/EIA-526 (Optical Power Loss Measurements of Installed Fiber Cable Plant to include OTDR)
- C. ANSI/TIA/EIA-568-C (Commercial Building Telecommunications Standard)
- D. ANSI/TIA/EIA-569-B (Commercial Building Standards for Telecommunications Pathways and Spaces)
- E. ANSI/TIA/EIA-598-C (Optical Fiber Cable Color Coding)
- F. ANSI/TIA/EIA-604 (Fiber Optic Connector Interchangeability Standard)
- G. ANSI/TIA/EIA-606-A (Administration Standard for the Telecommunications Infrastructure of Commercial Buildings)
- H. ANSI/TIA/EIA-607-A (Grounding & Bonding Requirements for Telecommunications in Commercial Buildings)
- I. ANSI/TIA/EIA-758-A (Customer-owned Outside Plant Telecommunications Cabling Standard)
- J. ANSI/TIA/EIA-854 (Full Duplex Ethernet Specification for 1000Mbps/s (1000BASE-TX) Operating over Category 6 Balanced Twisted-Pair Cabling)
- K. ANSI/TIA/EIA-862 (Building Automation Cabling Standard for Commercial Buildings)
- L. International Standards Organization/International Electro-technical Commission (ISO/IEC)
- M. Underwriters Laboratories (UL) Cable Certification and Follow Up Program
- N. National Electrical Manufacturers Association (NEMA)
- O. American Society for Testing Materials (ASTM)
- P. Institute of Electrical and Electronic Engineers (IEEE)
- Q. UL Testing Bulletin
- R. American National Standards Institute (ANSI)
- S. Telecommunications Distribution Methods Manual (BICSI)
- T. CSU's "Telecommunications Infrastructure Planning Standards" document (TIP)
- U. Cal Poly ITS, University Telecommunications Infrastructure Planning (UTIP) Standards

- V. NFPA 101 (NFPA 101 - Life Safety Code).
- W. NFPA 258 - Standard Test Method for Measuring Smoke Generated by Solid Materials.
- X. NFPA 70 - National Electrical Code
- Y. NFPA 72 National Fire Alarm & Signaling Code
- Z. CEC 2010 California Electrical Code (Title 24,
Part3) AA. The California Mechanical Code
- BB. IEEE's National Electrical Safety Code
- CC. ANSI C80.3 Specification for Zinc-coated Electrical Metallic
Tubing DD. ANSI/UL 797 Electrical Metallic Tubing
- EE. ANSI/ICEA S-83-596 - Fiber Optic Premises Distribution Cable Technical
Requirements FF. Federal Communications Commission (FCC) Part 15
- GG. Federal Communications Commission (FCC) Part
68 HH. NEMA VE1 Cable Tray Systems
- II. UL 497 Electrical Grounding and Bonding
Equipment JJ.UL 1479 Fire Tests of Through-Penetration
Fire Stops
- KK. ASTM E 814 Methods of Fire Tests of Through-Penetration Fire Stops
- LL. ASTM E 136 Test Method for Behavior of Materials in a Vertical Tube Furnace
at 750 degrees C
- MM. Rural Utility Services (RUS), Bulletin 1753F-201, Specifications for Acceptance
Tests and Measurements of Telephone Plant

1.5 SUBMITTALS

A. General

1. Review of submittals shall be for general compliance with the design concept and Contract Documents.
2. Comments or absence of comments shall not relieve the Contractor from compliance with the Contract Documents. The Contractor remains solely responsible for details and accuracy, for confirming and correlating all quantities and dimensions, for selecting fabrication processes, for techniques of construction, for performing the work in a safe manner, and for coordinating the work with that of other trades.
3. Submittals will be stamped as follows:

Stamp	Interpretation
-------	----------------

No Exceptions Noted	Fabrication, manufacture, or construction may proceed providing submittal complies with the Contract Documents.
Exceptions Noted <input type="checkbox"/> Resubmit for Record <input type="checkbox"/> No Resubmission Required	Fabrication, manufacture, or construction may proceed providing submittal complies with the Contract Documents and the Engineer's notations are complied with.
Revise and Resubmit	The submittal does not comply with the Contract Documents; do not proceed with fabrication, manufacture, or construction. The work and shop drawings are not permitted at the job site. Resubmit appropriate shop drawings.

4. No part of the work shall be started in the shop or in the field until the shop drawings and samples for that portion of the work have been submitted and accepted by the Cal Poly Designated Telecommunications Representative.
5. A minimum period of five working days, exclusive of transmittal time, shall be required in the Cal Poly Designated Telecommunications Representative's office each time a shop drawing, product data and/or samples shall be submitted for review. This time period shall be considered by the Contractor in the scheduling of the work.
6. Submit materials and equipment by manufacturer, trade name, and model number. Include copies of applicable brochure or catalog material.
7. Maintenance and operating manuals shall not be acceptable substitutes for shop drawings.
8. Identify each sheet of printed submittal pages (using arrows, underlining or circling) to show applicable sizes, types, model numbers, ratings, capacities and options actually being proposed. Cross out non-applicable information. Note specified features such as materials or paint finish.
9. Maintain a complete set of reviewed and stamped shop drawings and product data on site.

B. Samples

1. Samples as requested shall be physical examples that represent materials,

equipment or workmanship and establish standards by which the work will be judged. Samples shall not be returned to the Contractor.

C. Test Reports

1. Pre-Installation Testing Reports: Submit two sets of manufacturers or field-testing reports for those materials identified in the individual system Specification Sections as requiring that such reports shall be submitted.
2. Post-Installation Testing Reports: Submit a minimum of two sets of field-testing reports for those materials identified in the individual system Specification Sections as requiring that such reports shall be submitted.

D. Vender/Contractor/Supplier Information

1. Submit a complete typed list of all telecommunications infrastructure equipment manufacturers and material suppliers for the equipment proposed to be provided on this project, as well as names of all subcontractors.
2. Contractor must supply current manufacturer's certification for all employees involved in the installation of all materials contained as part of the Structured Cabling System.

E. Warranty info

1. Submit a copy of all relevant warranty information.

F. Product Documentation:

1. Documentation for submittals in the form of catalog cuts, manufacturer specifications, and other supporting printed material shall be bound in a single binder, tabbed, and separated by specification section, and submitted in its entirety for review and eventual delivery to the Cal Poly Designated Telecommunications Representative.

G. Shop Drawings

1. After the Contract is awarded, provide complete shop drawings as requested for each relevant section. Prior to submission, certify that the shop drawings shall be in compliance with the Contract Documents. Modify any work, which proceeds prior to receiving accepted shop drawings as required to comply with the Contract Documents and the shop drawings. The Cal Poly Designated Telecommunications Representative will provide detailed rack layouts specific to the project.
2. Shop drawings for each MDF, IDF, and SDF layout, specifically including details for wall-fields and rack mounting layouts shall be approved by a representative of the Cal Poly Designated Telecommunications Representative prior to installation. ~~See~~ See UTIP for typical room layouts.
3. For each room or area of the building containing telecommunications infrastructure equipment, submit the following:

- a. Floor plans, at not less than 1/8" scale, showing routing of telecommunications conduits, cable trays and other pathways.
- b. Riser diagrams showing types, quantities and schematic routing of all telecommunications backbone pathways, cabling and the PBB.
- c. Enlarged plan views and elevation layout drawings for each MDF, IDF, or SDF indicating the equipment in the exact location in which it is intended to be installed. These plans shall be of a scale not less than 1/4 inch = 1'-0". They shall be prepared in the following manner:
 - 1) Indicate the physical boundaries of the space including door swings and ceiling heights and ceiling types (as applicable).
 - 2) Illustrate all telecommunications hardware proposed to be contained therein. Include top and bottom elevations of all telecommunications hardware. The Drawings shall be prepared utilizing the dimensions contained in the individual equipment submittals. Indicate code and manufacturer's required clearances.
 - 3) Illustrate all other equipment therein such as conduits, detectors, luminaires, ducts, registers, pull boxes, wire-ways, electrical outlets, structural elements, etc.
 - 4) Illustrate concrete pads, curbs, etc.
 - 5) Indicate dimensions to confirm compliance with code-required clearances.
4. The work described in shop drawing submissions shall be carefully checked by all trades for clearances (including those required for maintenance and servicing), field conditions, maintenance of architectural conditions and coordination with other trades on the job.
5. Each submitted shop drawing shall include a certification that related job conditions have been checked by the Contractor and each Subcontractor and that conflicts do not exist.
6. The Contractor shall not be relieved of the responsibility for dimensions or errors that may be contained on submissions, or for deviations from the requirements of the Contract Documents. The noting of some errors but overlooking others does not grant the Contractor permission to proceed in error. Regardless of any information contained in the shop drawings, product data and samples, the Contract Documents govern the work and shall be neither waived nor superseded in any way by the review of shop drawings, product data and samples.
7. Inadequate or incomplete shop drawings, product data and/or samples

shall not be reviewed and shall be returned to the Contractor for resubmittal.

8. Indicate the following on the lower right-hand corner of each shop drawing and on the front cover of each product data brochure cover: The submittal identification number; title of the sheet or brochure; name and location of the project; names of the Architect, Engineer, Contractor, Subcontractor, manufacturer, and supplier; the date of submittal; and the date of each correction, version and revision. Number all pages and drawings in product data brochures consecutively from beginning to end. Unless the above information is included, the submittal shall be returned for re-submission. Resubmittals of product data or brochures shall include a cover letter summarizing the corrections made in response to the review comments.
9. The MDF, IDF, and SDF layout submittals and the related telecommunications equipment submittals shall be submitted concurrently. Failure to submit concurrently shall result in the immediate return of the submittal marked REVISE AND RESUBMIT.

1.6 IDENTIFICATION

- A. Also refer to Section 27 05 53.
- B. Label and identify each element as required for those individual system specification sections.
- C. Use examples in 27 00 02 - APPENDIX B Labeling-Design-Syntax for Shop Drawings and Submittals.

1.7 ABBREVIATIONS AND DEFINITIONS

A. ABBREVIATIONS

1.	ADA	Americans with Disabilities Act
2.	AFF	Above Finished Floor
3.	ANSI	American National Standards Institute
4.	ASTM	American Society for Testing and Materials
5.	BICSI	(Building Industry Consulting Service International)
6.	EIA	Electronic Industries Alliance
7.	ETL	Electrical Testing Laboratories, Inc.
8.	FCC	Federal Communications Commission

9.	FM	Factory Mutual
10.	IDF	Intermediate Distribution Frame, See UTIP for sample drawings
11.	ISO/IEC 11801 Ed.2:2002	
12.	IEEE	Institute of Electrical and Electronic Engineers
13.	LED	Light Emitting Diode
14.	MDF	Main Distribution Frame, See UTIP for sample drawings
15.	NEC	National Electric Code
16.	NEMA	National Electrical Manufacturers Association
17.	NFPA	National Fire Protection Association
18.	NRTL	Nationally Recognized Testing Laboratory
19.	OEM	Original Equipment Manufacturer
20.	OSHA	Occupational Safety and Health Administration
21.	PBB	Primary Bonding Busbar, See UTIP for samples
22.	SCC	Security Control Center
23.	SCS	Structured Cabling System
24.	SDF	Supplemental Distribution Frame, See UTIP for description
25.	TIA	Telecommunications Industries Association
26.	UL	Underwriters Laboratories
27.	UON	Unless Otherwise Noted

B. Telecommunications Definitions

1. **BACKBOARD:** Backboard generally refers to the A-C, fire-retardant, plywood sheeting lining the walls of the telecommunications facilities. Backboards may also refer to the entire wall-mounted assembly, including wire management and termination frames.
2. **CATV:** Cable Antenna Television System.
3. **CABLE PLANT:** Cable, conduit raceways, vaults, junction/pull boxes, rooms, racks, equipment, patch bays/blocks, and other infrastructure required to provide physical, electrical, optical connectivity between university buildings.
4. **CABLE TRAY:** Hardware designed and manufactured for horizontal pathway distribution of cable and inside wire from the MDF, IDF, or SDF to the wall plate or cable drop.
5. **DESIGNATION STRIPS:** Paper or plastic strips, usually contained in a clear or color tinted plastic carrier, designated for insertion into a termination frame. Designation strips are usually imprinted with the adjacent terminal number and are used to aid in locating a specific pair, group of pairs, or information

- outlet inserted into the termination frame, or for the purpose of delineating a termination field.
6. ENTRANCE CONDUIT: Conduit that connects the underground infrastructure with the building's MDF.
 7. HORIZONTAL CABLE: See STATION CABLE
 8. MPOE/DEMARK: Minimum Point of Entry, Utility Partnerships/Alternate Carrier and inaccessible or non-standard customer wiring located in or connected to an MDF.
 9. WIRE MANAGEMENT HARDWARE:
 - a. Fiber Management: Hardware designed and manufactured for the purpose of keeping fiber patch cords neat and orderly. Most termination frame manufacturers provide fiber management components designed to work in conjunction with their termination frames. Fiber management may also refer to other types of hardware for the purpose of securing fiber optic cable to the building.
 - b. Wire Management (Copper, Data, Network): Hardware designed and manufactured for the purpose of keeping cross-connect wire and patch cables neat and orderly. Most termination frame manufacturers provide wire management components designed to work in conjunction with their termination frames. Wire management may also refer to other types of hardware for the purpose of securing wire and cable to the building.
 10. OUTSIDE PLANT (OSP): Communications system components outside of the buildings (typically underground conduit and vaults, exterior/underground rated wire, cable, fittings, etc.).
 11. RISER CABLE: High volume cable (copper) that connects between the MDF and IDFs or SDFs located on the same or different floors. All riser cable is to be plenum rated.
 12. RISER CONDUIT: Conduit that connects between the MDF and IDFs or SDFs located on the same or different floors.
 13. RISER FIBER CABLE: Fiber Optic Cables that connects between the MDF and IDFs or SDFs located on the same or different floors. All Fiber Optic Cable to be plenum rated.
 14. ROOM TAXONOMY
 - a. Main Distribution Frame (MDF): The MDF is where the outside plant (OSP) cables connect (through protection devices and distribution cross-connects) to the telecommunications, data and CATV

- “backbone”. See the UTIP document for design aspects, sizing, use restrictions, and layout samples for the MDF.
- b. Intermediate Distribution Frame (IDF): IDFs are added telecommunication spaces to serve either more building floor space or other floors of a building. See the UTIP document for design aspects, sizing, use restrictions, and layout samples for IDFs.
 - c. Supplemental Distribution Frame (SDF): SDFs are special purpose spaces that serve very small number of cable drops, special building areas like pools or athletic areas, or are used to reduce long cables into specific rooms like computer labs. See the UTIP document for design aspects, sizing, and use restrictions for SDFs.
15. STATION CABLE: 4 pair, unshielded uniform twisted pair, category rated wire that connects the end user information faceplate or cable drop to the MDF, IDF ,or SDF. All station cable to be plenum rated.
 16. TELECOMMUNICATIONS GROUNDING/BONDING SYSTEM: ###
 - a. ### - BICSI.
 17. TELECOMM/DATA DEMARK: (Surface Mounted Conduit & Boxes Only and/or no Suspended Ceiling)
 - a. A pair of separately mounted 4-11/16” square, 2-1/4” deep electrical boxes. In one box terminate a run of data cable from the MDF, IDF, or SDF using a single (or more if necessary) RJ45 jack, mounted in an appropriate faceplate. In the other box terminate cable(s) that shall be used to connect directly to a piece of manufactured equipment or a non-ITS supported network. To complete the cable run(s) use a “male RJ45” to “male RJ45” jumper plugged into each faceplate. (See Fig. #166 in 27 00 02 - APPENDIX B Labeling-Design-Syntax).
 18. TELECOMM/DATA DEMARK: (In-wall Conduit and Back Boxes with a Suspended Ceiling)
 - a. Conduit and wiring shall be installed to a standard, in-wall 4-11/16” square, 2-1/4” deep electrical box. The port connectors for cables to be connected directly to user equipment shall be pushed back into the back box and an extension cable shall be attached and the extension cable shall be run to the area above the hung ceiling where it will be coiled for customer use. The empty faceplate holes shall be filled with snap-in blank fillers. (See Fig. #167 in 27 00 02 - APPENDIX B Labeling-Design-Syntax)

1.8 WARRANTY

- A. Submit a single guarantee stating that the work is in accordance with the Contract Documents. The warranty shall include all labor to replace any defective components as well as the component replacement at current market price. Guarantee work against faulty and improper material and workmanship for a period of one year from the date of final acceptance by the University and/or the Cal Poly ITS Telecom Group, except where guarantees or warranties for longer terms shall be provided or specified herein, the longer term shall apply. Correct any deficiencies, which occur during the guarantee period, within 24 hours of notification, without additional cost to the University, and to the satisfaction of the Cal Poly Designated Telecommunications Representative. Obtain similar guarantees from subcontractors, manufacturers, suppliers, and sub-trade specialists.
- B. Structured Cabling System (SCS) Manufacturers Extended Warranty
 - 1. Installation contractor shall have current manufacturer's certification for all materials contained as part of the SCS. All employees shall have current certifications for the materials they are installing.
 - 2. Documentation proving the cabling system's compliance to the End-to-End Link Performance recommendations, as listed in ANSI/TIA/EIA-568 shall be provided by the Contractor prior to the structured cabling system being installed.
 - 3. The cabling system shall conform to the current issue of industry standard ANSI/TIA/EIA-568.
 - a. All performance requirements of this document shall be followed. As well, workmanship and installation methods used shall be equal to or better than that found in the BICSI (Building Industry Consulting Service International) ITSI (Information Transport Systems Installation) manual and the Cal Poly ITS, University Telecommunications Infrastructure Planning (UTIP) Standards.
 - 4. The University demands strict adherence to the performance specifications listed in ANSI/TIA/EIA-568 series standards.
 - 5. Manufacturer shall maintain ISO Quality Control registration for the facilities that manufacture the product used in this cabling system.

PART 2 – PRODUCTS

2.1 EQUIPMENT AND MATERIALS

A. SECTION 27 06 00 - SCHEDULES FOR COMMUNICATIONS

- 1. It is recommended that the reader examine Section 27 06 00 - Schedules for Communications before continuing.

2. Section 27 06 00, Schedules for Communications presents the Cal Poly ITS Telecom Group's pre-approved Product/Material Listing by Division 27 Section number. In this specification set product/material shall be specified by reference to the Product/Materials Schedule contained in Section 27 06 00.
 3. The Contractor shall supply a complete and functioning system; if a product/material required for this project is not listed in Section 27 06 00 - Schedules for Communications, Products and Materials Schedule, it shall be furnished by Contractor with submittal approval by the Cal Poly Designated Telecommunications Representative.
- B. Use only products listed for their intended use by a Nationally Recognized Testing Laboratory, except products for which no relevant standards exist.
 - C. Provide products and materials that are new, clean, free of defects, and free of damage and corrosion.
 - D. Products and materials shall not contain asbestos, PCB, or any other material, which shall be considered hazardous by the Department of Environmental Protection or any other authority having jurisdiction.
 - E. Maintain uniformity of manufacturer for equipment used in similar applications and sizes.
 - F. Follow manufacturer's instructions for installing, connecting, and adjusting equipment. Provide a copy of such instructions at the equipment during installation.
 - G. Enclosures for Telecommunications Systems and Components equipment installed in mechanical equipment rooms shall be NEMA type 1 with gasket. Enclosures for telecommunications infrastructure equipment installed outdoors shall be NEMA type 4.
 - H. Ship and store all products and materials in a manner that will protect them from damage, weather and entry of debris. If items are damaged, do not install, but take immediate steps to obtain a replacement. Repairs of damaged goods shall only be permitted with prior written permission of the Cal Poly Designated Telecommunications Representative.
 - I. Part numbers and product codes in these specifications shall be correct as of the time of writing. Manufacturers may, however, change part numbers and product codes on short notice. In cases where part numbers or product codes differ from technical specifications for a particular product, provide products that meet the minimum technical specifications of the products in the specifications. The contractor shall notify the Cal Poly Designated Telecommunications Representative of any product code and or part number changes on the material list submittal.
 - J. Product Consistency: Any given item of equipment or material shall be the

product of one manufacturer throughout the project. Multiple manufacturers of any one item will not be permitted, unless specifically noted otherwise on approved drawings or contract documents.

2.2 SPECIAL TOOLS

- A. Deliver to Cal Poly Designated Telecommunications Representative two complete sets of all special tools and small equipment items needed for proper ongoing operation, adjustment, and maintenance of cabling and equipment installed under this work.
- B. All tools to be new and still in manufacturers packaging. The cost for these tools is to be included within the bid price for this work.
- C. The terms "special tools" and "small equipment items" is meant to include such items as punch down tools, connector assembly tools, etc. with each individual item having a retail replacement cost not exceeding five hundred dollars (\$500.00). It is NOT meant to include common hand tools such as standard screwdrivers, pliers, wrenches, etc.
- D. Submit the tool list along with the bid for this work. Include add/delete unit pricing for all tools on the list.

2.3 SUBSTITUTIONS

- A. Contract Documents shall be based on equipment manufacturers as called out in the Specifications and indicated on the Drawings. Acceptance of substitute equipment manufacturers shall not relieve Contractor of the responsibility to provide equipment and materials, which meet the performance as stated or implied in the Contract Documents.
- B. Submit proposals to provide substitute materials or equipment, in writing, with sufficient lead-time for review prior to the date equipment is ordered to maintain projectschedule.
- C. Substitutions that increase the cost of the work and related trades shall not be permitted.
- D. Proposals for substitutions shall include the following information:
 - 1. A description of the difference between the Contract Document requirements and that of the substitution, the comparative features of each, and the effect of the change on the end result performance. Include the impact of all changes on other contractors and acknowledge the inclusion of additional costs to the other trades.
 - 2. Schematic drawings and details.
 - 3. List of revisions to the Contract Documents that must be made if the substitution is accepted.
 - 4. Estimate of costs the University may incur in implementing the substitution,

such as test, evaluation, operating and support costs.

5. Statement of the time by which a Contract modification accepting the substitution must be issued, noting any effect on the Contract completion time or the delivery schedule.
 6. A statement indicating the reduction to the Contract price if the Cal Poly Designated Telecommunications Representative accepts the substitution. Include required modifications to all related trades.
- E. Final acceptance of Telecommunications Systems and Components designs, and substitutions shall be as follows:
1. Final acceptance/approval of all Telecommunications Systems and Components designs and substitutions shall be at the sole discretion of the Cal Poly Designated Telecommunications Representative.

PART 3 – EXECUTION

3.1 GENERAL

A. Work Included

1. Provide labor and materials required to install, test, and place into operation the telecommunications infrastructure systems as called for in the Contract Documents, and in accordance with applicable codes and regulations.
2. Provide labor, materials, and accessories required to provide complete, operating telecommunications infrastructure systems.
3. Labor, materials, or accessories not specifically called for in the Contract Documents, but required to provide complete, operating infrastructure systems shall be provided without additional cost to the University.

B. Fees and Permits

1. Pay all required fees and obtain all required permits related to the telecommunications infrastructure installation.
2. Pay royalties or fees in connection with the use of patented devices and systems.
3. Provide controlled inspection where required by the authority having jurisdiction or by these specifications.

C. Coordination of work

1. The Contract Documents establish scope, materials, and quality, but are not detailed installation instructions. Drawings are diagrammatic.

2. Coordinate work with related trades and furnish, in writing, any information necessary to permit the work of related trades to be installed satisfactorily and with the least possible conflict or delay.
3. The telecommunications infrastructure drawings show the general arrangement of equipment and appurtenances. Follow the appropriate drawings as closely as the actual construction and the work of other trades will permit. Provide offsets, fittings, and accessories, which may be required but not shown on the Drawings. Investigate the site, and review drawings of other trades to determine conditions affecting the work and provide such work and accessories as may be required to accommodate such conditions.
4. The locations of cable termination fields, faceplates, patch panels, equipment racks and other equipment indicated on the Drawings are approximately correct, but they are understood to be subject to such revision as may be found necessary or desirable at the time the work is installed in consequence of increase or reduction of the number of faceplates, or in order to meet field conditions, or to coordinate with modular requirements of ceilings, or to simplify the work, or for other legitimate causes. The final designs shall be accepted by the Cal Poly Designated Telecommunications Representative prior to installation.
5. Exercise particular caution with reference to the location of outlets/faceplates, racks, blocks, patch panels, control panels, switches, etc., and have precise and definite locations accepted by the Cal Poly Designated Telecommunications Representative before proceeding with the installation.
6. The Drawings show only the general run of raceways and approximate locations of faceplates. Any significant changes in location of faceplates, cabinets, etc., necessary in order to meet field conditions shall be brought to the immediate attention of the Cal Poly Designated Telecommunications Representative for review before such alterations are made. Modifications shall be made at no additional cost to the University.
7. Verify with the Cal Poly Designated Telecommunications Representative the exact location and mounting height of faceplates and equipment not dimensionally located on the Drawings. For power distribution to equipment located in equipment racks see 27 00 02 - APPENDIX B Labeling-Design-Syntax.
8. Faceplate/cable labels in the form of alpha/numeric characters are used where shown to indicate the faceplate and cable designation numbers in cable termination fields (terminal blocks and/or patch panels). Show the actual faceplate/cable numbers on the as-built Record Drawings, on the associated typed termination field labels and in the printed and computer readable cabling schedules. Where faceplate/cable- numbering information is not indicated, request clarification from the Cal Poly Designated

Telecommunications Representative.

9. Wherever work interconnects with work of other trades, coordinate with other trades to ensure that they have the information necessary so that they may properly install the necessary connections and equipment. Identify items (remote ballast, pull boxes, etc.) requiring access in order that the Ceiling Trade will know where to install access doors and panels.
10. Furnish and set sleeves for passage of telecommunications risers through structural masonry and concrete walls and floors and elsewhere as required for the proper protection of each telecommunications riser passing through building surfaces.
11. Provide appropriate re-enterable firestop materials around all pipes, conduits, ducts, sleeves, etc. which pass through rated walls, partitions, and floors.
12. Provide detailed information on openings and holes required in precast members for telecommunications work.
13. Provide required supports and hangers for conduit and equipment, designed so as not to exceed allowable loadings of structures.
14. Examine and compare the Contract Drawings and Specifications with the Drawings and Specifications of other trades and report any discrepancies between them to the Cal Poly Designated Telecommunications Representative and obtain written instructions for changes necessary in the work. Install and coordinate the work in cooperation with other related trades. Before installation, make proper provisions to avoid interferences.
15. Before commencing work, examine adjoining work on which this work is in any way affected and report conditions, which prevent performance of the work. Become thoroughly familiar with actual existing conditions to which connections must be made or which must be changed or altered.
16. Adjust location of conduits, panels, equipment, etc., to accommodate the work to prevent interferences, both anticipated and encountered. Determine the exact route and location of each conduit prior to fabrication.
 - a. Right-of-Way: Lines which pitch shall have the right-of-way over those which do not pitch.
 - b. For example: condensate, steam, and plumbing drains normally have right-of-way. Lines whose elevations cannot be changed have right-of-way over lines whose elevations can be changed.
 - c. Provide offsets, transitions and changes in direction of conduit as required to maintain proper headroom and pitch on sloping lines.
17. In cases of doubt as to the work intended, or in the event of need for

explanation, request supplementary instructions from the Cal Poly Designated Telecommunications Representative.

18. Coordinate with Cal Poly Designated Telecommunications Representative for access into existing campus telecommunication spaces.

D. Cutting and Patching

1. Where cutting, channeling, chasing, or drilling of floors, walls, partitions, ceilings or other surfaces shall be necessary for the proper installation, support or anchorage of conduit or other equipment, layout the work carefully in advance. Repair any damage to the building, piping, equipment and/or defaced finished plaster, woodwork, metalwork, etc. using skilled tradespeople of the trades required at no additional cost to the University.
2. Do not cut, channel, chase or drill unfinished masonry, tile, etc., unless permission from the Cal Poly Designated Telecommunications Representative is obtained. If permission is granted, perform this work in a manner acceptable to the Cal Poly Designated Telecommunications Representative.
3. Where conduit or equipment is mounted on a painted finished surface, or a surface to be painted, paint to match the surface. Cold galvanize bare metal whenever support channels are cut.
 - a. Provide slots, chases, openings and recesses through floors, walls, ceilings, and roofs as required. Where these openings are not provided, provide cutting and patching to accommodate penetrations at no additional cost to the University.

E. Cleaning Up

1. Avoid accumulation of debris, boxes, loose materials, crates, etc., resulting from the installation of this work. Remove from the premises each day all debris, boxes, etc., and keep the premises clean and free of dust and debris.
2. Clean all fixtures and equipment at the completion of the project. Wipe clean exposed lighting fixture reflectors and trim pieces with a non-abrasive cloth just prior to occupancy.
3. All MDF, IDF, and SDF spaces shall be thoroughly vacuumed and wiped clean prior to bringing online and at the completion of the project. Equipment shall be opened for observation by the Cal Poly Designated Telecommunications Representative as required.

F. Delivery, Drayage and Hauling

1. Provide drayage, hauling, hoisting, shoring and placement in the building of equipment specified and be responsible for the timely delivery and installation of equipment as required by the construction schedule. If any item of equipment is received prior to the time that it is required, the Contractor shall be responsible for its proper storage and protection until

the time it is required. Pay for all costs of demurrage or storage.

2. If equipment is not delivered or installed at the project site in a timely manner as required by the project construction schedule, the Contractor shall be responsible for resulting disassembly, re-assembly, manufacturer's supervision, shoring, general construction modification, delays, overtime costs, etc. at no additional cost to the University.

G. Equipment and Material Protection

1. Protect the work, equipment, and material of other trades from damage by work or workmen of this trade and correct damaged caused without additional cost to the University.
2. It is the contractor's responsibility for work, materials, and equipment until finally inspected, tested, and accepted. Protect work against theft, injury, or damage, and carefully store material and equipment received on site, which is not immediately installed. Close open ends of work with temporary covers or plugs during construction to prevent entry of obstructing material. Cover and protect equipment and materials from damage due to water, spray-on fireproofing, construction debris, etc.
3. Provided adequate means for fully protecting finished parts of materials and equipment against damage from whatever cause during the progress of the work until final acceptance. Protect materials and equipment in storage and during construction in such a manner that no finished surfaces will be damaged or marred and are kept clean and dry. Do not install damaged items; take immediate steps to obtain replacement or repair.

3.2 QUANTITIES

A. N/A

3.3 INSTALLATION

A. Mounting Heights

1. Mounting heights shall conform to ADA requirements.
2. Contractor responsible for the physical mounting of devices must have knowledge and understanding of ADA requirements.
3. Mounting heights shall be from floor to center of outlet, unless otherwise noted. Verify exact locations and mounting heights with the Cal Poly Designated Telecommunications Representative before installation.
4. Wall mounted devices requiring operational access shall be mounted a minimum of 15 inches above finished floor to bottom of device and a maximum of 48 inches above finished floor to the operating mechanism.

B. Waterproofing

1. Avoid, if possible, the penetration of any waterproof membranes such as roofs, machine room floors, basement walls, and the like. If such penetration is necessary, make penetration prior to the waterproofing and furnish all sleeves or pitch-pockets required. Contact the Cal Poly Designated Telecommunications Representative and the Cal Poly Facilities Project Manager and obtain written permission from the Cal Poly Facilities Project Manager before penetrating any waterproof membrane, even where such penetration is shown on the Drawings.
2. Restore waterproofing integrity of walls or surfaces after they have been penetrated without additional cost to the University.

C. Supports

1. Support work in accordance with the strictest manufacturer written recommendation per code or the best industry practice. Provide supports, hangers, auxiliary structural members, and supplemental hardware required for support of the work.
2. Provide supporting frames or racks extending from floor slab to ceiling slab for work indicated as being supported from walls where the walls are incapable of supporting the weight. Provide such frames or racks in MDF, IDF, or SDF rooms.
3. Provide supporting frames or racks for equipment, which is installed in a freestanding position meeting Seismic Zone 4 requirements.
4. Supporting frames or racks shall be plumb and square with parallel side rails of standard angle, standard channel, or specialty support system steel members, rigidly bolted or welded together and adequately braced to form a substantial structure. Racks shall be of ample size to assure a workmanlike arrangement of all equipment mounted on them.
5. Adequate support of equipment (including faceplate, back, pull and junction boxes and fittings) shall not depend on electric conduits, raceways, or cables for support.
6. Telecommunications equipment shall not rest on or depend for support on suspended ceiling media. Provide independent support of telecommunications equipment. Do not attach to supports provided for ductwork, piping, or work of other trades.
7. Provide required supports and hangers for conduit, equipment, etc., so that loading will not exceed allowable loadings of structure. Telecommunications equipment and supports shall not come in contact with the work of other trades.

D. Fastenings

1. Fasten equipment to building structure in accordance with the strictest manufacturer written recommendation, per code or the best industry

- practice and while meeting Seismic Zone 4 requirements.
2. Where weight applied to the attachment points is 100 pounds or less, conform to the following as a minimum:
 - a. Wood: Wood screws.
 - b. Concrete and solid masonry: Bolts and expansion shields.
 - c. Hollow construction: Toggle bolts.
 - d. Solid metal: Machine screws in tapped holes or with welded studs.
 - e. Steel decking or sub-floor: Fastenings as specified below for applied weights more than 100 pounds.
 3. Where weight applied to building attachment points exceeds 100 pounds, but is 300 pounds or less, conform to the following as a minimum:
 - a. At concrete slabs provide 24-inch x 24-inch x ½ inch steel fishplates on top with through bolts. Fishplate assemblies shall be chased in and grouted flush with the top of slab screed line, where no fill is to be applied.
 - b. At steel decking or sub-floor for all fastenings, provide through bolts or threaded rods.
 - c. The tops of bolts or rods shall be set at least one inch below the top fill screed line and grouted in. Suitable washers shall be used under bolt heads or nuts. In cases where the decking or sub-floor manufacturer produces specialty hangers to work with his decking or sub-floor such hangers shall be provided.
 4. Where weight applied to building attachment points exceeds 300 pounds, coordinate with, and obtain the approval of the Cal Poly Designated Telecommunications Representative and conform to the following as a minimum:
 - a. Provide suitable auxiliary channel or angle iron bridging between building structural steel elements to establish fastening points. Bridging members shall be suitably welded or clamped to building steel. Provide threaded rods or bolts to attach to bridging members.
 5. For items, which are shown as being ceiling mounted at locations where fastening to the building construction element above is not possible, provide suitable auxiliary channel or angle iron bridging tying to the building structural elements.

6. Wall mounted equipment may be directly secured to wall by means of steel bolts. Groups or arrays of equipment may be mounted on adequately sized steel angles, channels, or bars.

E. Equipment pads and Anchor Bolts

1. Provide concrete pads under all floor-mounted telecommunications equipment where specifically required by the Specifications or shown on the Drawings. Equipment pads shall conform to the shape of the piece of equipment it serves with a minimum 1-inch margin around the equipment and supports. Pads shall be a minimum of 4 inches high and made of a minimum 28 day, 2500psi concrete reinforced with 6-inch x 6-inch 6/6-gauge welded wire mesh. Trowel tops and sides of pad to smooth finishes, equal to those of the floors, with all external corners bull-nosed to a $\frac{3}{4}$ inch radius. Shop drawings stamped NO EXCEPTIONS NOTED shall be used for dimensional guidance in sizing pads.
2. Provide galvanized anchor bolts for all equipment placed on concrete equipment pads, inertia blocks, or on concrete slabs. Provide bolts of the size and number recommended by the manufacturer of the equipment and locate by means of suitable templates. Equipment installed on vibration isolators shall be secured to the isolator. Secure the isolator to the floor, pad, or support as recommended by the vibration isolation manufacturer.
3. Where equipment is mounted on gypsum board partitions, the mounting screws shall pass through the gypsum board and securely attach to the partition studs. As an alternative, the mounting screws may pass through the gypsum board and be securely attached to 6 inches square, 18-gauge galvanized metal back plates, which are attached to the gypsum board with an approved non-flammable adhesive. Toggle bolts installed in gypsum board partitions are not acceptable.

3.4 GROUNDING & BONDING

- A. See individual sections for specific details.
- B. Refer to Section 27 05 26 for additional details.

3.5 TESTING

- A. Comply with the project construction schedule for the date of final performance and acceptance testing, and complete work sufficiently in advance of the Contract completion date to permit the execution of the testing prior to occupancy and Contract Closeout. Complete any adjustments and/or alterations, which the final acceptance tests indicate as necessary for the proper functioning of all equipment prior to the completion date. Refer to Specification Section 27 08 13 and 27 08 23 for extent of testing required.
- B. Provide a detailed schedule of completion indicating when each system is to be

completed and outlining when field-testing will be performed. Submit completion schedule for review within six months after the notice to proceed by Cal Poly Designated Telecommunications Representative has been given. Update this schedule periodically as the project progresses.

3.6 ACCEPTANCE

- A. Perform all tests required by local authorities, in addition to tests specified herein.
- B. Technicians shall be ready with all necessary tools, test equipment, and supplies necessary to troubleshoot and correct cabling system faults.
- C. Upon receipt of the Contractor's documentation of cable testing, the Cal Poly Designated Telecommunications Representative will review/observe the installation and randomly request tests of the cables/wires installed. Once the testing has been completed and the Cal Poly Designated Telecommunications Representative is satisfied that all work is in accordance with the Contract Documents, the Cal Poly Designated Telecommunications Representative will notify the Contractor or Cal Poly Facilities Project Manager in writing.
- D. Specific system acceptance requirements are listed in the appropriate specification section.
- E. Final Punch List
 - 1. Prior to the Final Punch list, certify that all Telecommunications Systems and Components and equipment are complete, operational, and are in compliance with the Contract Documents.
 - 2. Any deficiencies noted on the Final Punch list shall be expeditiously corrected and certified in writing.
- F. Operating and Maintenance manuals
 - 1. Provide Operating and Maintenance Manuals and Training of maintenance personnel for equipment and materials furnished under each Division.
 - 2. Maintenance manuals shall include complete cleaning and servicing data compiled in a clear and easily understandable format. Show model numbers of each piece of equipment, complete lists of replacement parts, capacity ratings, and actual loads.

3.7 RECORD (AS-BUILT) DRAWINGS

- A. Record dimensions clearly and accurately to delineate the work as installed; suitably identify locations of all equipment by at least two dimensions to permanent structures. In addition, mark the Record Drawings to show the precise location of concealed work and equipment, including concealed or embedded raceways and cables and all changes and deviations in the Telecommunications Systems and Components work form that shown on the Contract Documents. All faceplates and Wireless Access Points shall be indicated with label IDs

1. This requirement shall not be used as authorization to make changes in the layout or work. In a neat and accurate manner, provide a complete record of all revisions of the original drawings, as actually installed. The cost for these documents shall be included in the Contract. Submit drawings in AutoCAD and PDF format on CD for review. After review, make necessary changes to documents and then deliver electronic copies of the final documentation to the Cal Poly Designated Telecommunications Representative.
 - a. Submit electronic copies of the final record drawings in AutoCAD and PDF format.
 - b. Submit electronic copies of the as-built telecommunications cabling schedules as comma delimited ASCII format files (or other mutually acceptable media and format).
 - c. Submit electronic copies of final test results for all cabling systems.

END OF SECTION

SECTION 27 00 02 – APPENDIX B Labeling-Design-Syntax

PART 1 - General

The following information is provided to further define the end results that the Cal Poly ITS Telecom Group shall use to evaluate Division 27 and related work performed on the University Campus.

Figure number labeling of various items and locations:



Figure 101: Backboard label to be stenciled on appropriate MDF/IDF/SCF wall (Building 171A, Room 21 – West Wall) in every telecom space.



Figure 102: Hard-line CATV Cable label between MDF and MDF (Building 171A-Room 21 to Building 171A-Room 217).



Figure 103: Labeling of a fiber shelf in a rack (Fiber- Multimode-Building 2 to Building 14-Room 103- Multimode strands 1 to 24).

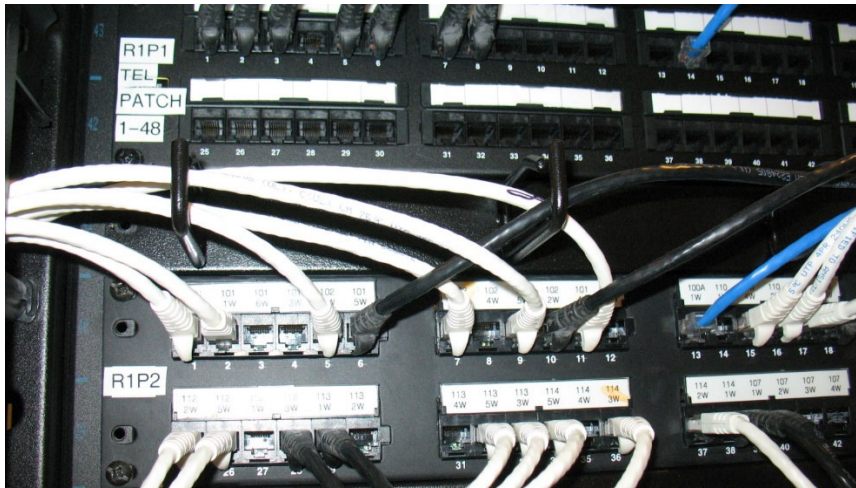

Figure 104: Patch panel labeling, R1P1, 1-48 phone and R1P2 (Rack 1, Patch Panel 2) data.

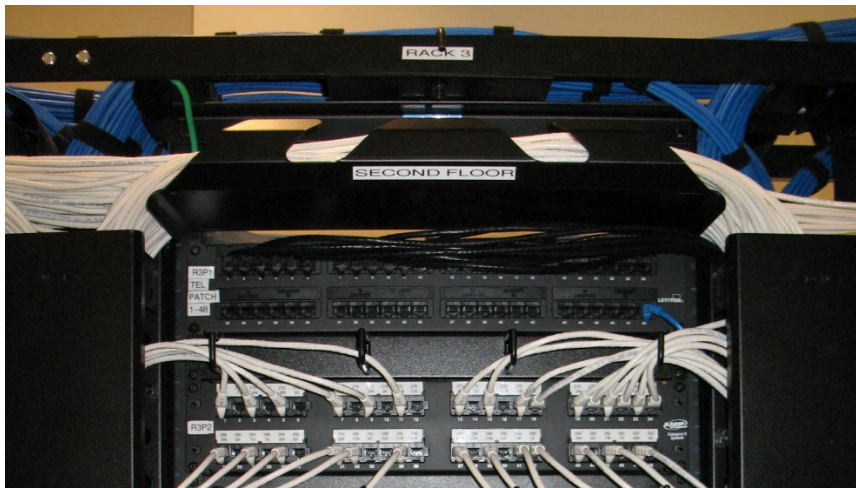

Figure 105: Rack labeling is affixed to the ladder racking above and centered on the rack. Floor location is affixed to the cable trough mounted at the top of each rack.



Figure 106: Protector labeling for a cable pairs 1 through 100 that goes from building 20B, room 100 (only room in building) to building 180, room 106.



Figure 107: Structured Cable, CAT 6, labeled with the faceplate room and port served.

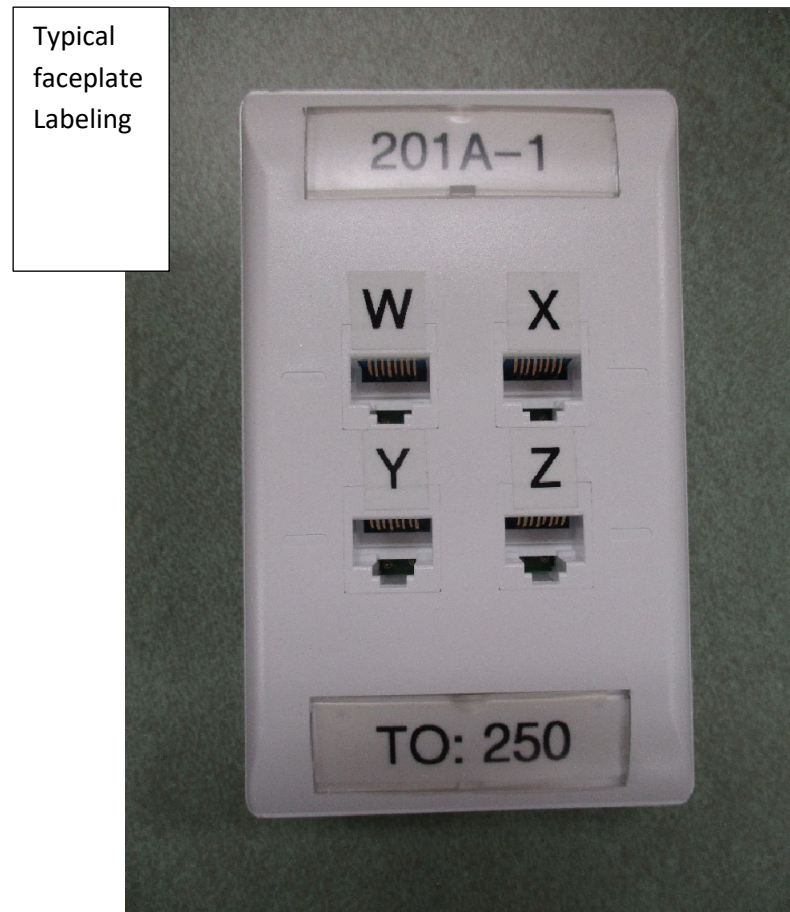

Figure 108: Two 4 port faceplates in the most common configurations found on campus. The upper label identifies the specific faceplate within a room. A number such as 204A-01 would mean, when entering room 204A, which is a room within room 204, starting on your left and going around the room, faceplate 204A-01 would be the first faceplate you should come to in that room. The lower label indicates the room number of the TR/ER that supports the jacks installed in the faceplate. The wiring connected to the rear of the connectors/jacks (see Figure 107) should have labels identifying which port they serve; “W” (upper left),”X” (upper right),”Y” (lower left) or “Z” (lower right).

**LABELING STANDARDS
FACEPLATES**

Use this format to label Faceplates, Campus wide.

FACEPLATES NEED THREE TYPES OF LABELS ON THEM:

- The Top Label indicates the Room and Faceplate location Number.
- The Lower Label indicates the Telecommunications Space the Cables go to.
- Be sure to label the Jacks (WXYZ) properly for Angled and non-Angled Faceplates. In some Angled-style Faceplates, the Jacks are “up-side-down.”
- The U, V, W, X, Y and Z Jacks should always be in the same relative position. If the Faceplate needs to be positioned on its side, turn it 90 degrees counter-clockwise (the “top” now on the left).
- All labels must be **mechanically produced**.

Examples: Here are some examples of various Faceplate configurations.

Angled 4 Port

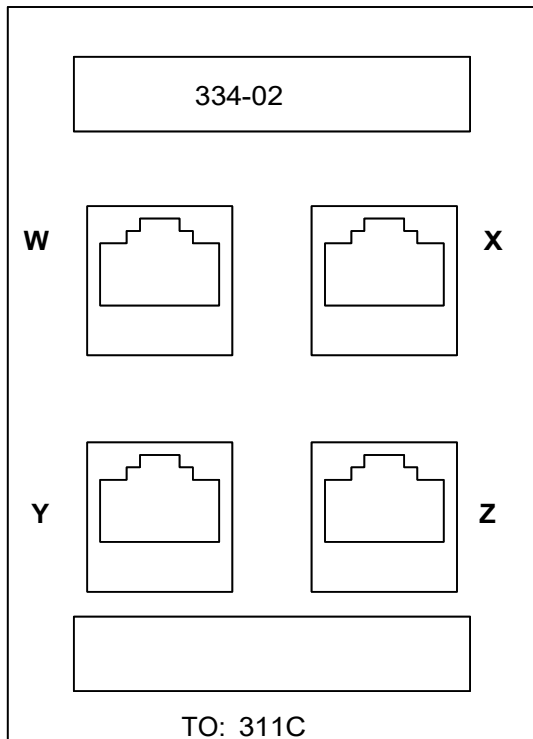

Figure
109

Straight 4 Port

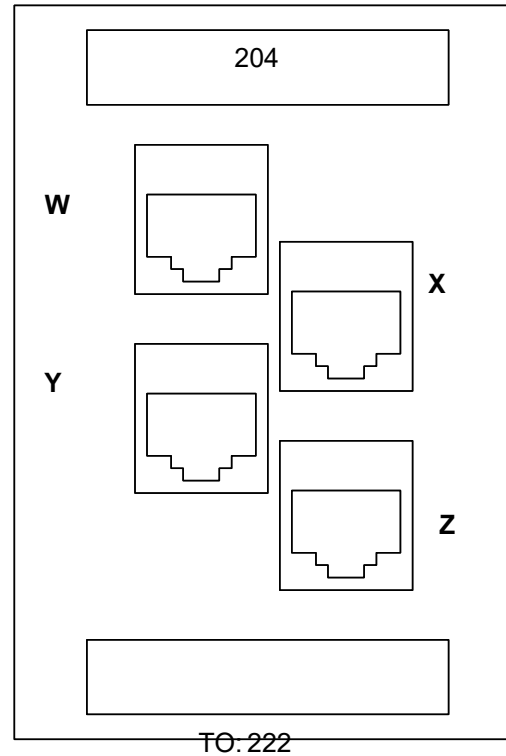

Figure
110

Straight 3 Port with Cable TV

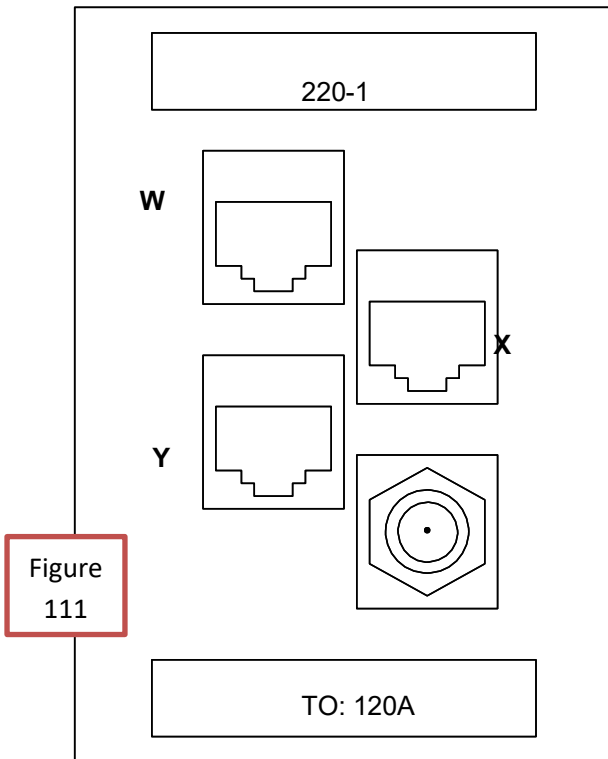

Figure
111

Straight 2 Port

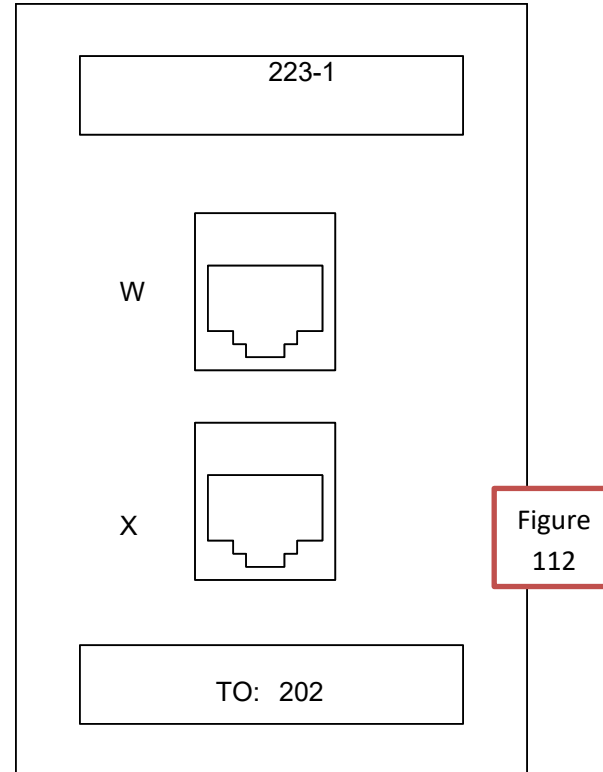

Figure
112

Angled 3 Port

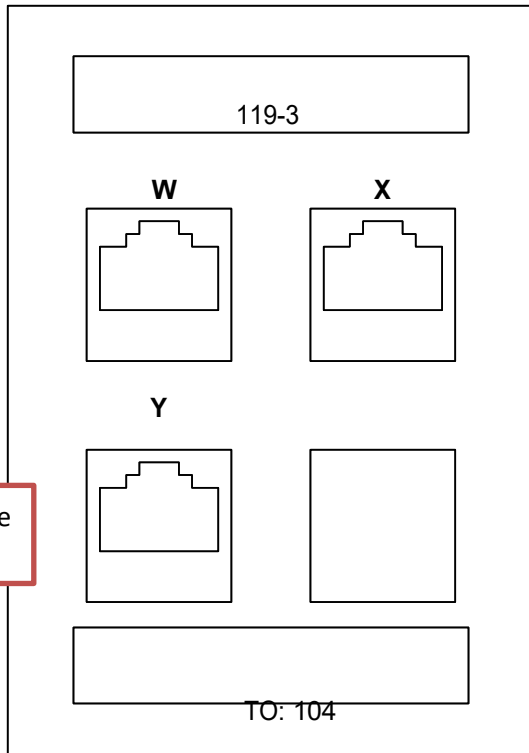

Figure
113

Straight 6 Port

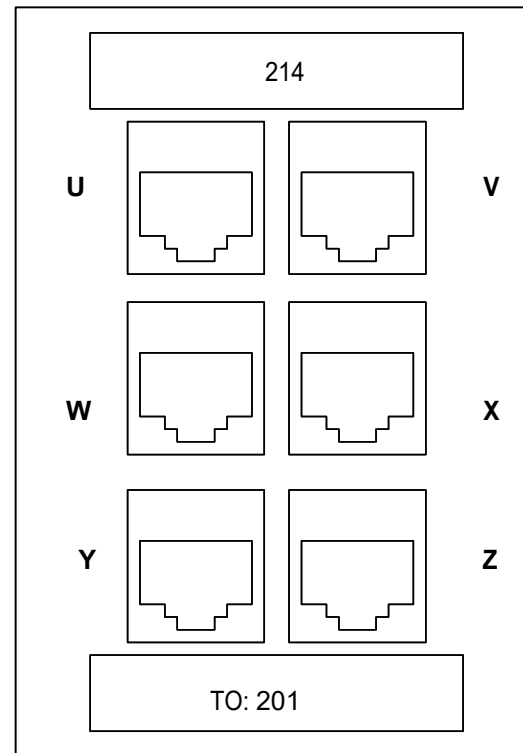
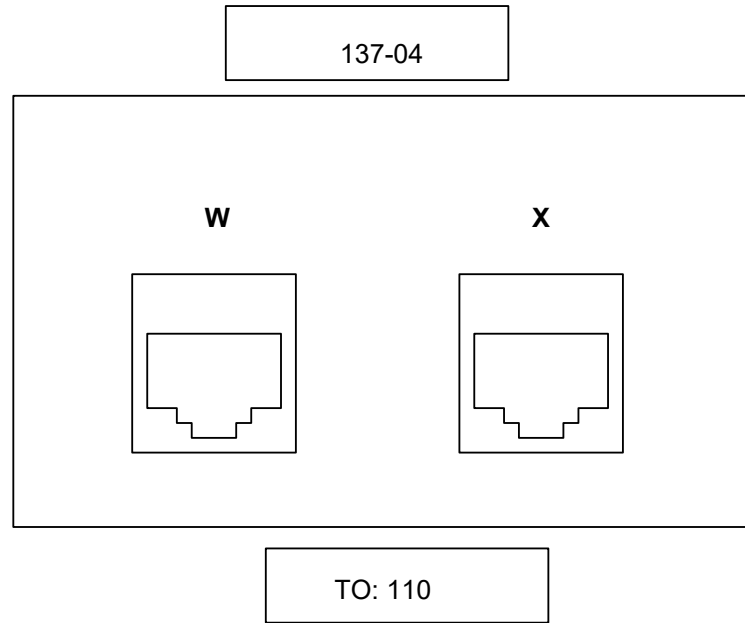

Figure
114

Modular Furniture 2 Port



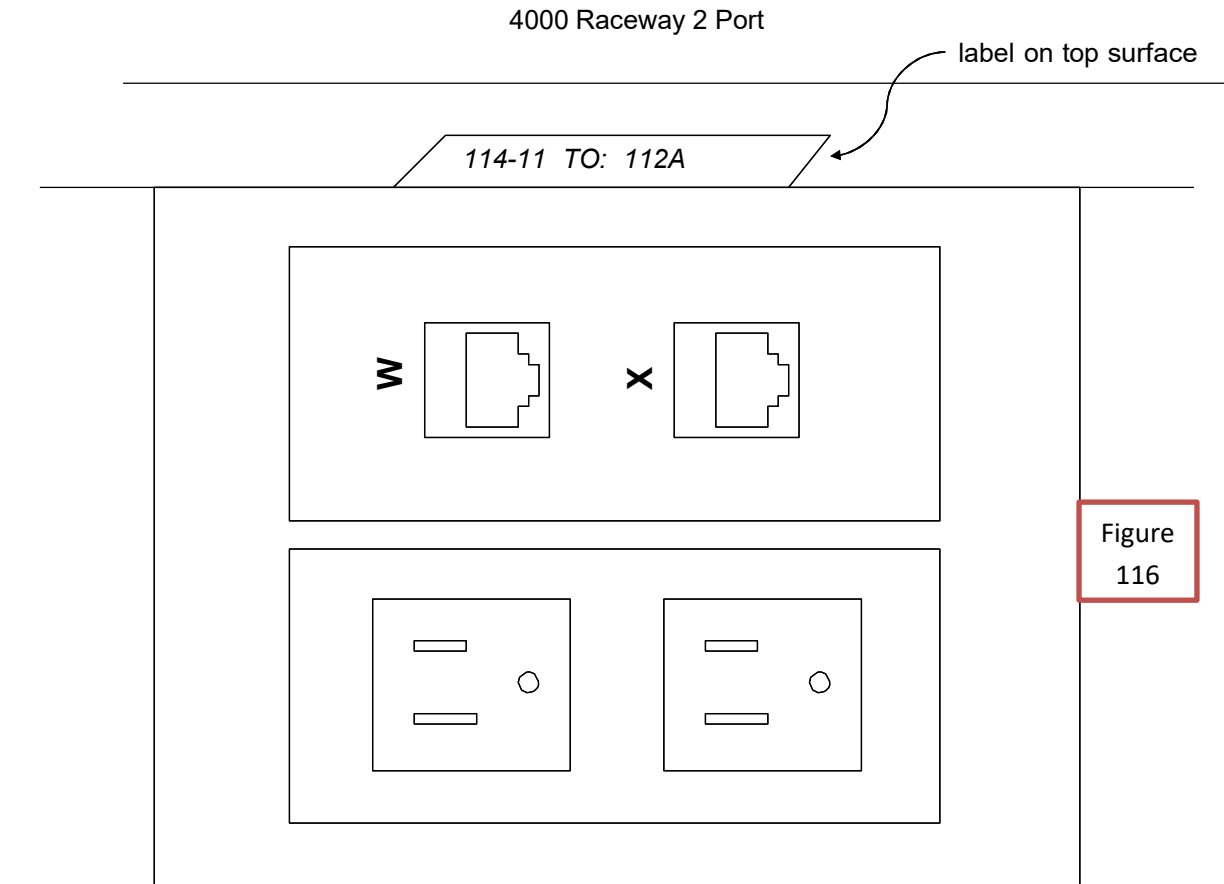

Figure
116

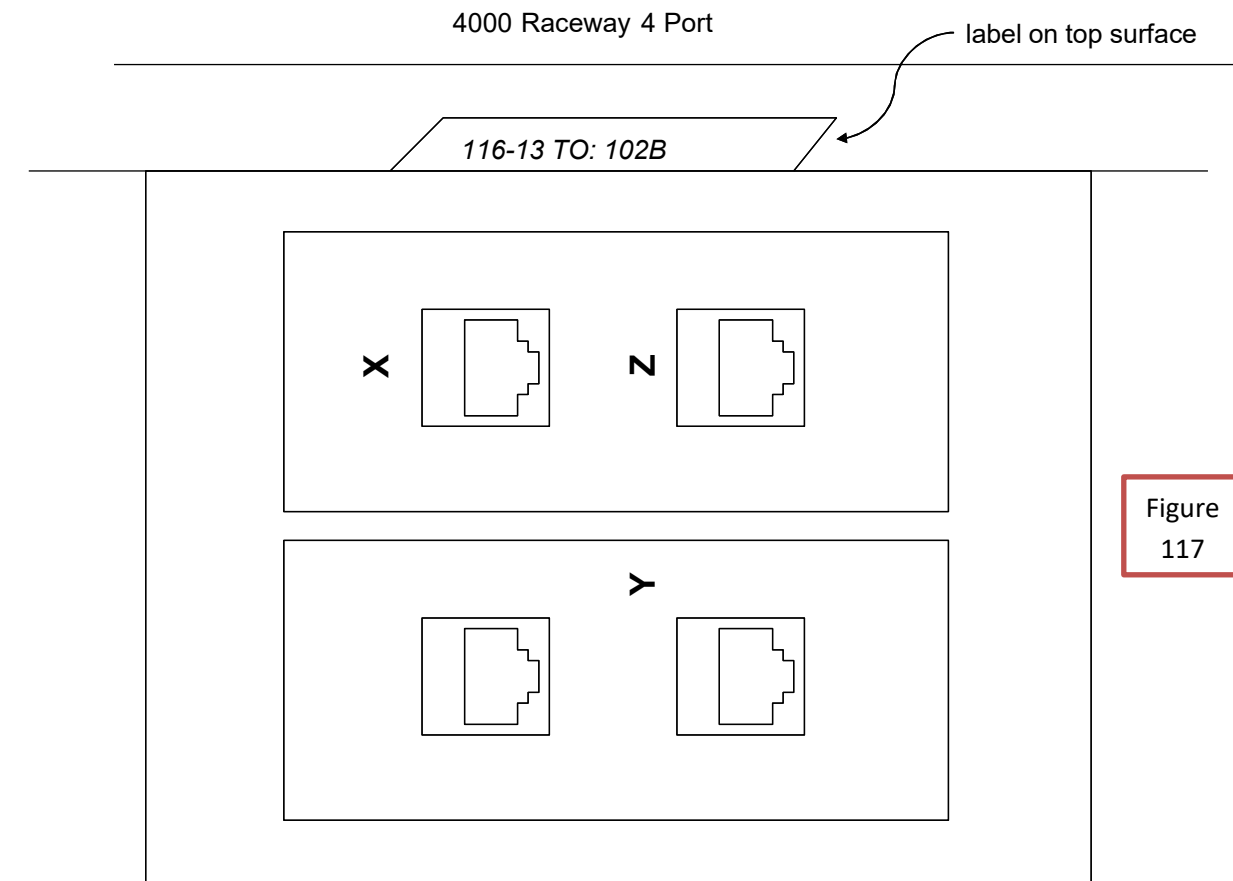

Figure
117

Straight 3 Port

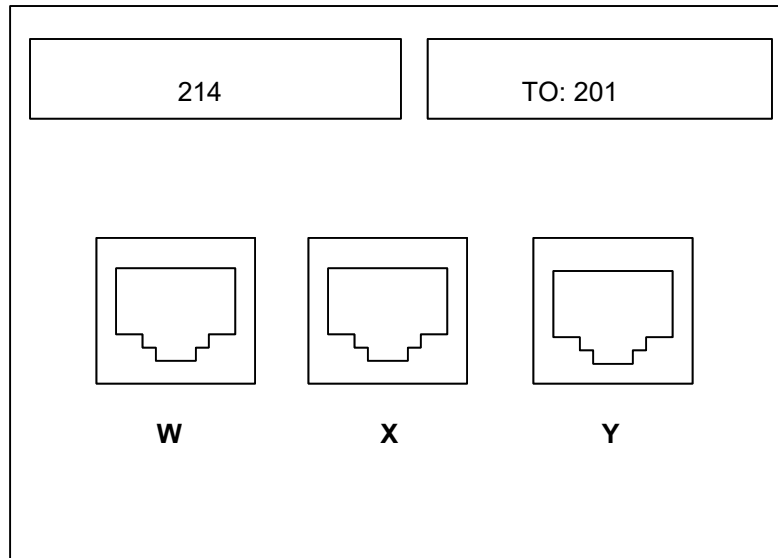
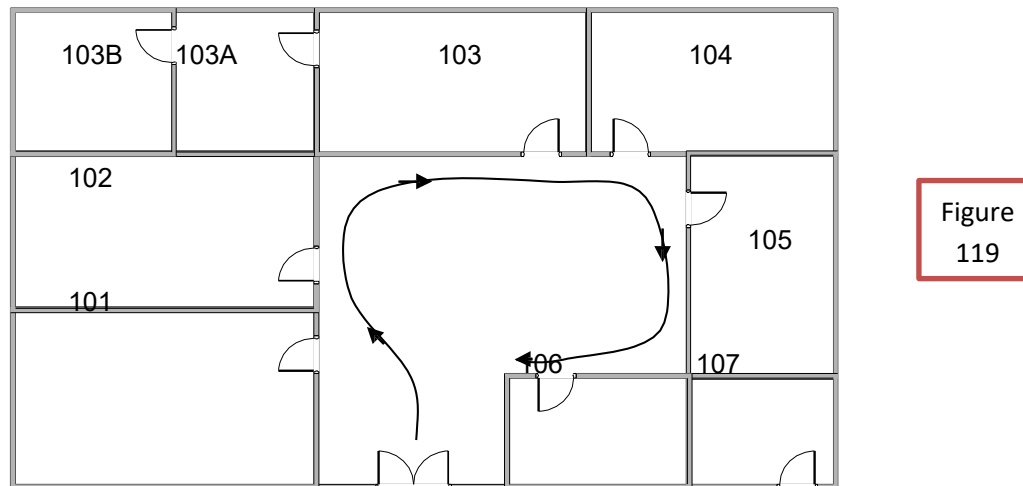

Figure
118

CAL POLY I.T.S. ROOM & FACEPLATE NUMBERING SCHEME

FIGURE 1 - ROOM NUMBERING



LEVEL AND ROOM NUMBERS SHALL BE PROVIDED BY CAL POLY FACILITIES PLANNING.

1. ALL ROOMS ON SAME ELEVATION LEVEL SHALL HAVE COMMON PRIMARY DIGIT, I.E., ALL FIRST LEVEL FLOORS ARE "1XX", SECOND LEVEL ARE "2XX", ETC.
2. ROOMS ARE NUMBERED FROM MAIN ENTRANCE IN A CLOCK-WISE PATTERN. ROOMS WHICH ARE ACCESSIBLE ONLY THRU ANOTHER ROOM ARE NUMBERED 'A'-'B'-'C', ETC. OF THE OUTER ROOM NUMBER (E.G., 103A, 103B, ETC).
3. EXTERIOR ROOMS ARE NUMBERED FOLLOWING HIGHEST NUMBERED INTERIOR ROOM.

FIGURE 2 – FACEPLATE NUMBERING

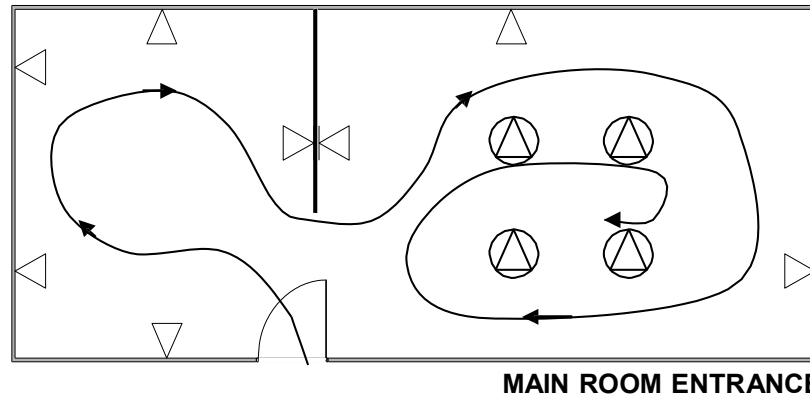

Figure
120

1. IN ANY GIVEN NUMBERED ROOM, FACEPLATES ON THE WALLS SHALL BE NUMBERED IN A CLOCK-WISE PATTERN BEGINNING FROM THE MAIN ENTRANCE OF THAT ROOM.
2. AFTER NUMBERING ALL FACEPLATES ON WALLS, THEN NUMBER FACEPLATES ON TELE- POLES, FLOOR MONUMENTS OR OTHER "ISLAND" LOCATIONS BY SPIRALLING IN CLOCKWISE TOWARDS THE CENTER OF THE ROOM.
3. REFER TO FACEPLACE LABELING SHEET FOR COMPLETE NUMBER/LABEL SYNTAX.

Location Numbering:

Signal Man Holes: **“SMH”** followed by a two-digit number, plus a letter, if required. Signal Pull Holes: **“SPH”** followed by a two-digit number, plus a letter, if required. Signal Pull Boxes: **“SPB”** followed by a two-digit number, plus a letter, if required. Pedestals: **“PED”** followed by a two-digit number, plus a letter, if required.

Buildings: **“B”** followed by a three digit Building number and then a letter where appropriate. See examples below.

Rooms: **“B”** for Building followed by a three digit Building number with letter if needed, then a “ - “ and a three digit Room number with letter if needed.

Backboards: If there is only a Backboard on one wall of a Room, no designation is needed. If more than one Backboard exists, then they must be differentiated with a **W, E, N** or **S** for **West, East, North** or **South** wall location.

Location Numbering Examples:

- Signal Man Hole / Pull Hole / Pull Box Numbers: **SMH05, SPH84, SPB103**
- Pedestal Numbers: **PED05, PED11**
- Building Numbers: **B001, B133, B043A**
- Room Numbers: **B001-207, B117T-102, B047-021K, B052-F004**

Room Connection Point Numbering:

Rack Panel Ports: **-RaPbPtxx** is a **Rack (a), Panel (b)** and **Port (xx)**

Faceplate Jacks: **-aU, aV, aW, aX, aY** or **aZ** are for Jacks on a Faceplate where “a” is the number of the Faceplate counting clockwise around the Room from the Main Entrance.

Note: All of these connection points shall be preceded by a Building and Room designation.

Room Connection Point Numbering Examples:

- Port Numbers: **002-004-R1P2Pt16**, Port 16, in Panel 2, on Rack 1, in Room 004, Building 002.
- Faceplate Jack Numbers: **002-016C-3W**, is the “W” jack on the third Faceplate in Room 016C of Building 002

Conduit Numbering:

Conduits are designated by their Source and Destination locations, Sequence Number of the Conduit in that bank of Conduits and then its Diameter in 1/100ths of an inch.

The order is standardized to have the Lower Numbered Pedestal (PED) first for Pedestal-to-Pedestal Conduits, the Lower Numbered Signal Man Hole (SMH) first for SMH-to-SMH Conduits, the Pedestal first for Pedestal-to-SMH Conduits and the SMH first for SMH-to-Building Conduits.

The order sequences where **PED** = Pedestal, **SMH** = Signal Man Hole, **SPH** = Signal Pull Hole, **SPB** = Signal Pull Box, and **B** = Building are:

PED before **SMH**, **SPH**, **SPB** and **B** **SMH** before **SPH**, **SPB** or **B**
SPH before **SPB** of **B** **SPB** before **B**

The syntax is **SMHxx/SMHyy/Dzz-aaa** where xx and yy are the **Signal Man Hole** numbers, zz is the number of the Conduit in its duct bank and aaa is the diameter of the Conduit in 100ths of an inch.

Conduit Numbering Examples:

- **PED01/SMH13A/D02-400**, is the second Conduit from Pedestal 01 to Signal Man Hole 13A and is 4" in diameter.
- **SMH10/SMH11/D03-300**, is the third Conduit in the Signal Man Hole 10 to Signal Man Hole 11 Duct bank and it is 3" in diameter.
- **SPH02/B108/D03-400**, is the third Conduit from Signal Pull Hole number 02 to Building 108 and it is 4" in diameter.

Cable Numbering:

Cables are identified by their Source and Destination locations. THE ORDER IS IMPORTANT. The Source is the Pedestal for Pedestal-to-Building cables; the Lower Numbered Pedestal or Building for Pedestal-to-Pedestal or Building-to-Building cables; and the Lower Numbered Room for Riser or Station Cables in the same Building.

Outside Plant Cables (OSP):

Twisted Pair Copper Cable Examples:

- **PED04/PED07**, Pedestal 04 to Pedestal 07, Pedestal 04 is the Source and Pedestal 07 is the Destination.
- **PED05/B124-117A**, Pedestal 05 to Building 124-Room 117A, Pedestal 05 is the Source.
- **B002-004/B060-101A**, Cable from Building 002 Room 004 to Building 060 Room 101A.

Fiber Optic Cable Examples:

- **FMB115-000/B124-225A** is a Fiber Optic cable between Building 115 Room 000 and Building 124 Room 225A.
- “**FM**” before any cable designator indicates a **Multimode** Fiber Optic cable; • “**FS**” is a **Single mode** Fiber.
- **FSPED03/PED08-2** where the “-2” indicates a Second Cable of Multiple cables between the same two end points.

Coaxial Cable Examples:

- **CPED02/PED03-8** is the Eighth Coaxial Cable between Pedestal 02 and Pedestal 03. A “**C**” before any cable designates a Coaxial cable.

Note: Buildings have 3-digit Numbers plus a Letter, if required, and Pedestals have 2- digits plus a Letter, if required.

Riser and Station Cable Numbering:

Copper Cable Examples:

- **B010-118/B010-218** is a Riser Cable between Rooms 118 and 218 in Building 010.
- **B002-004E/B002-004-S** is a Cable between the East Backboard in Building 002 Room 004 and the South Backboard.
- **B002-004S/B002-004-R1P10-02** is the second Cable from the South Backboard in Building 002 Room 004 to the Number 10 Patch Panel on Rack 1 in Building 002 Room 004.
- **B002-004-R1P1Pt16/B002-016C-1W** is a Station Cable from Rack 1, Panel 1, Port 16 in 002-004 to the “W” Jack on the first (of two or more) Faceplate in Building 002 Room 016C.

Fiber Cable Examples:

- **FMB021-123/B021-202** is a Multimode Fiber Optic Cable from in Building 021 Room 123 to in Building 021 Room 202.
- **FSB001-501B/B014-103** is a Single mode Fiber Optic Cable from Building 001 Room 501B to Building 014 Room 103.

LABELING STANDARDS
BACKBOARDS AND PUNCH BLOCKS

Use this Standard to label Backboards and Punch Blocks in Telecommunications Spaces.

BACKBOARDS: *BUILDING-ROOM-WALL*

-This Label shall be written with lettering stencils at the top of each installed Backboard.

Example:

-Building 107, Room 100D, South Wall: **BD107-100D-SOUTH**

-Building 053A, Room 100, West Wall **BD053A-100-WEST**

PUNCH BLOCKS:

-Punch Blocks are referenced by their Backboard Number followed by an individual Block Designation Number, with numbering beginning over with each Wall / Backboard in the Telecommunications Space.

-66M-1 Blocks shall be numbered independent of each other from left to right, top to bottom. An exception is when blocks are stacked directly on top of one another. They shall then be numbered in columns.

Example:
Typical Backboard Layout:

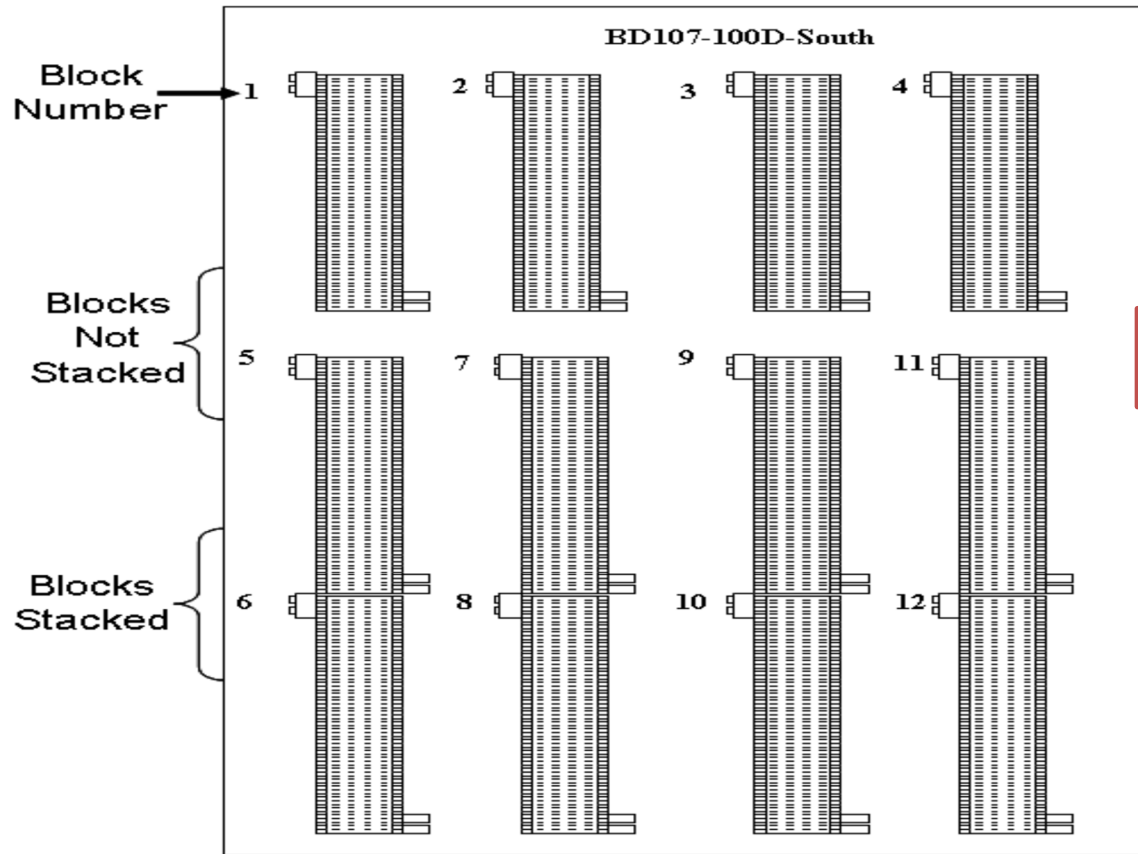
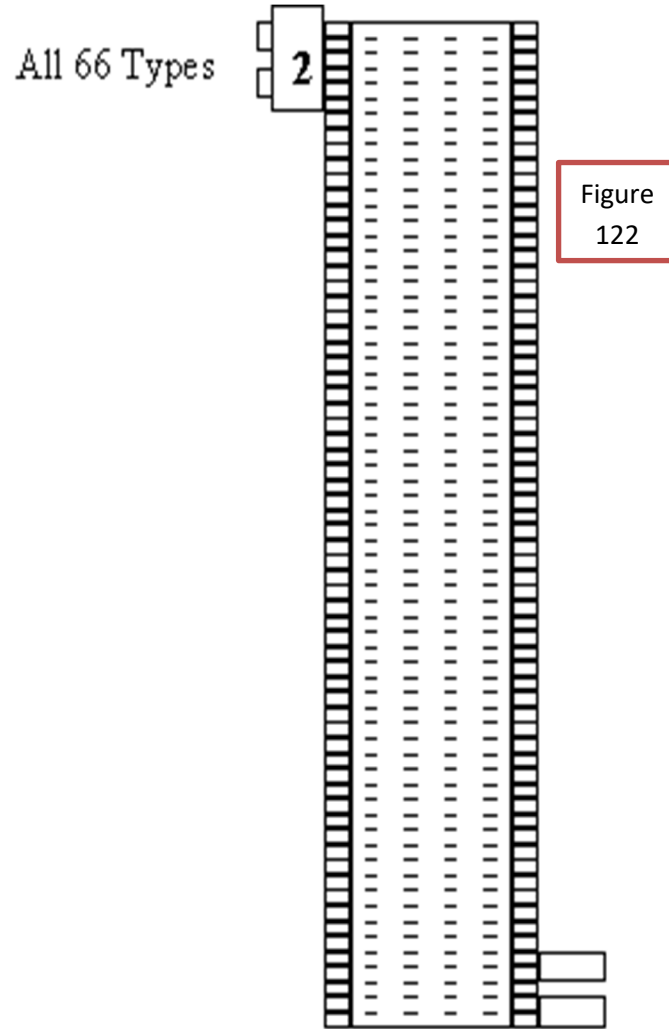

Figure
121

-Example of 66M-1 Block Label Positioning:



LABELING STANDARDS

RACKS AND PATCH PANELS

This standard should be used for labeling Racks and Patch Panels.

RACKS: *RACK #* **Examples:** **RACK 1, RACK 2, RACK 3**, etc.

-Free-standing Racks shall be numbered and labeled from the wall outward, that is, the Rack touching the wall of the Telecommunications Space shall be numbered "RACK 1", and the next Rack out from the wall shall be numbered "RACK2", etc.

-Ideally, the Rack immediately to your left is RACK ONE when viewed from the Racks' front side. With Racks against the right-hand wall of the Telecommunications Space, the numbering will be reversed, but will allow ascending numbers to be used as more Racks are added.

-Wall-Mounted Racks shall be numbered and labeled in ascending numerical order in a clock-wise pattern around the Telecommunications Space, beginning at the main entrance.

-The Label shall be placed at the top of the Rack, if it can be clearly seen. If obscured from view, the label shall be placed on ladder raceway, centered directly above the Rack.

-All labels shall be mechanically produced.

PATCH PANELS: *RACK # PANEL #* **Examples:** **R1P1, R1P2, R2P2**, etc.

-Place the Patch Panel Labels centered on the extreme left and right edges on each type of Patch Panel, where space is available. Do not cover individual Port Labeling areas with the Patch Panel number Labels.

-Start at the top of the Rack and label sequentially downward.

-Do not count Horizontal Wire Management, which shall be between each Panel and / or Active Device, plus one each at the extreme top and bottom of all rack equipment.

-Do not count as Panels any Active Devices, such as Hubs, Switches, Routers, UPS's, etc.

-Patch Panels are normally at the top of a Rack while Active Devices are toward the bottom.

-If there are pre-existing Panels (which are already labeled), new Patch Panels are numbered higher since they have been installed later. In other words, do not change the labels of existing Patch Panels just because they are below the new ones that you are installing.

-All labels shall be mechanically produced.

Example: Rack Numbering and Labeling

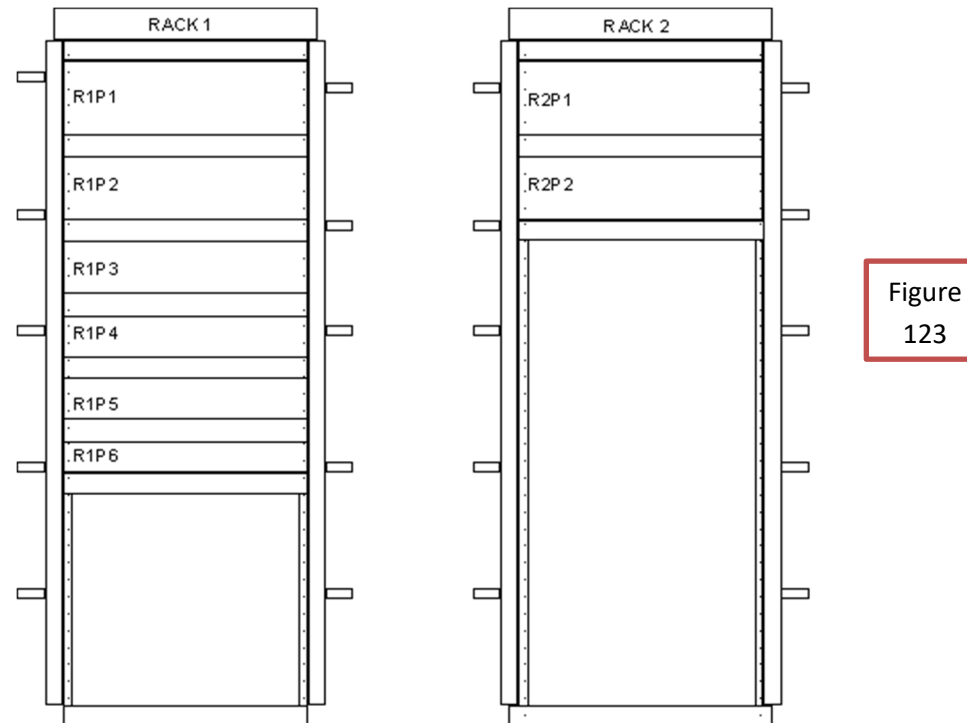

PATCH PANEL PORT LABELS:

Templates for Patch Panel Labels are available at: 'S:\ITS\CCS\TECH\Documentation\AllCircuit Documentation Sheets\All Templates for Documentation'.

-Each individual Port Label shall consist of the Room and Faceplate / Jack Number that Port connects to. Style of Labels shall match Patch Panel and will vary by manufacturer.

-Individual Ports on a Patch Panel are named: **Rack#Panel#Port##: R1P1Pt01, R2P3Pt18.**

-All Patch Panel Labels shall be mechanically produced.

Example:

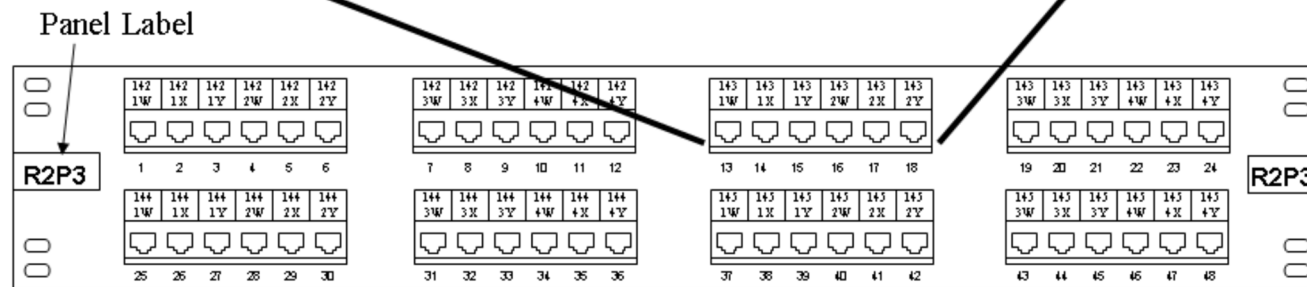
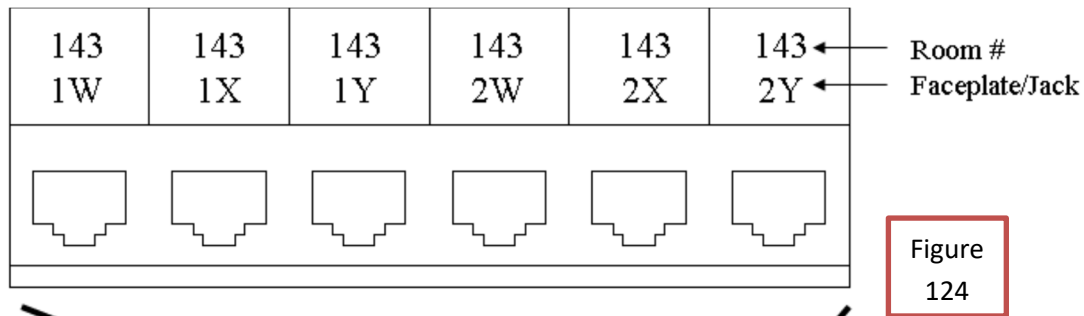

CAMPUS STANDARD POSITIONS OF ITEMS IN TELECOMM RACK: Generic Rack Layout with 1 Rack

Figure
125

FOR FIBER OPTIC TERMINATION BOXES:
PLACE CAMPUS FIBER BACKBONE CABLE FIRST. REMAINING CABLES FOLLOW IN **ASCENDING NUMERICAL ORDER** BY BUILDING/ROOM NUMBER.

FOR ALL FIBER CABLES WITH A COMMON END POINT, PLACE MM FIRST, SM SECOND.

ADD OR LEAVE 25% FREE FOR FUTURE GROWTH.

IDEAL COMPONENT LAYOUT IN SINGLE RACKS SHALL HAVE:

1. ONE RACK UNIT OPEN AT THE TOP (TO CLEAR THE "J" HOOKS).
2. FIBER OPTIC TERMINATIONS (BOX, PANELS, SHELVES, ETC.).
3. COPPER PATCH PANELS, EACH SEPARATED BY A DOUBLE WIRE-MANAGEMENT UNIT.
4. ACTIVE DEVICES (HUBS, SWITCHES, ROUTERS, ETC.)
5. RACK SHELVES SHOULD BE ATTACHED AT THE LOWEST RACK UNIT FOR ITEMS SUCH AS U.P.S.'s, P.C.'s, SERVERS, ETC.

VERTICAL WIRE MANAGEMENT, FRONT & BACK STYLE BOTH SIDES OF EACH RACK. TYP.

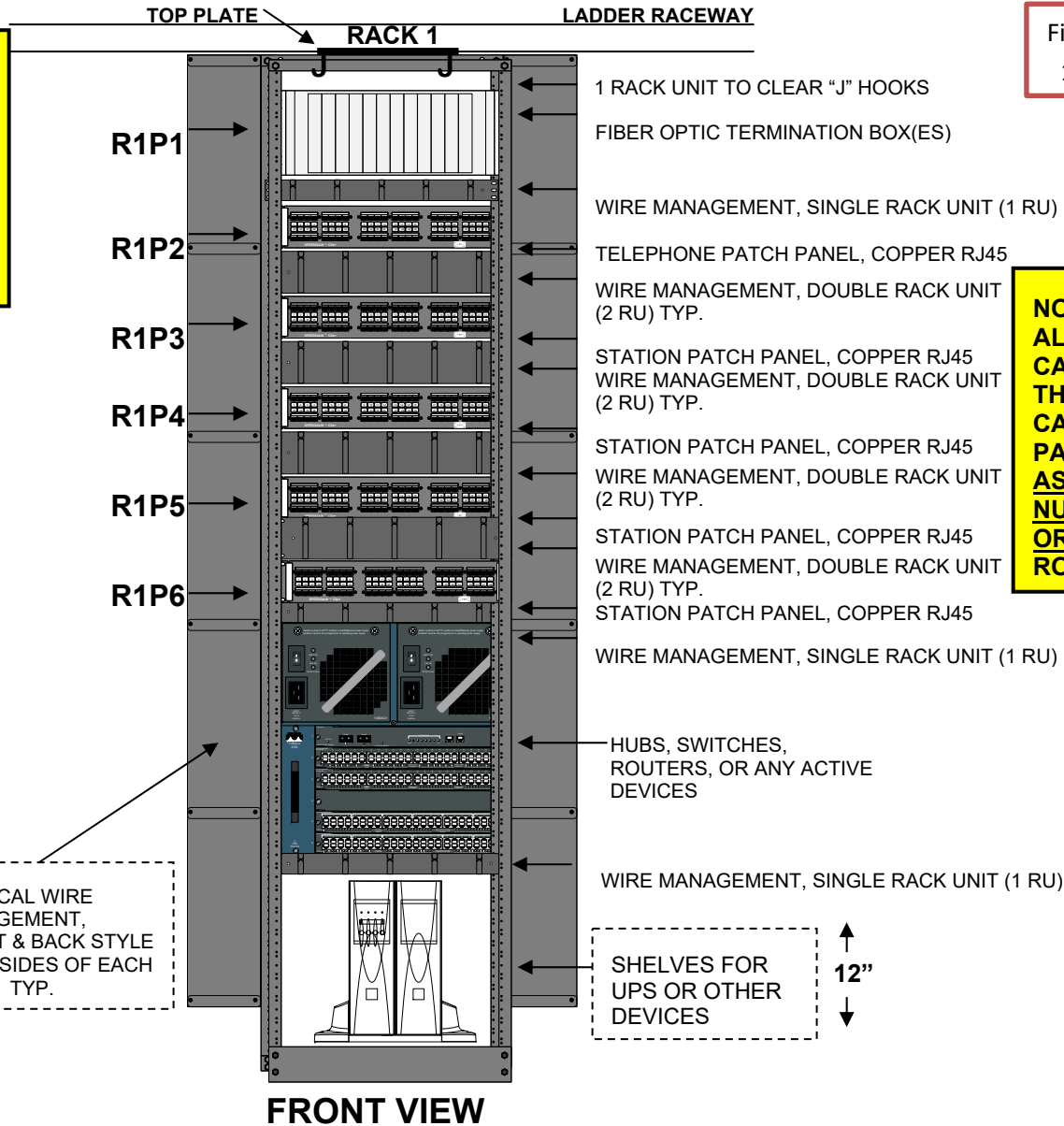

NOTE: PLACE ALL STATION CABLES INTO THE STATION CABLE PATCH PANELS IN ASCENDING NUMERICAL ORDER BY ROOM.

CAMPUS STANDARD POSITIONS OF ITEMS IN TELECOMM RACK: Generic Rack Layout with 2 Racks

Figure 126

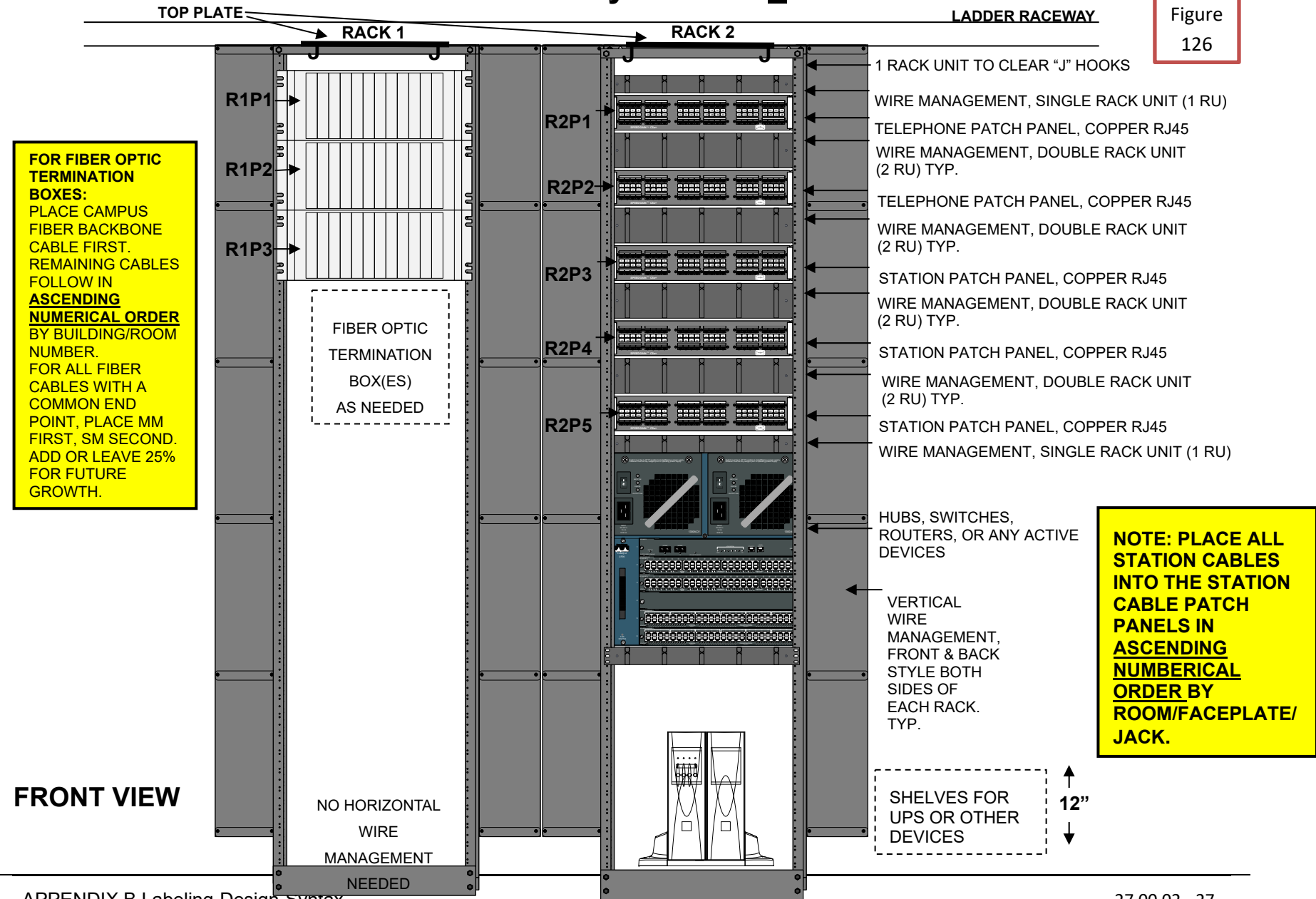

CAMPUS STANDARD POSITIONS OF ITEMS IN TELECOMM RACK: Generic Rack Layout with 3 Racks

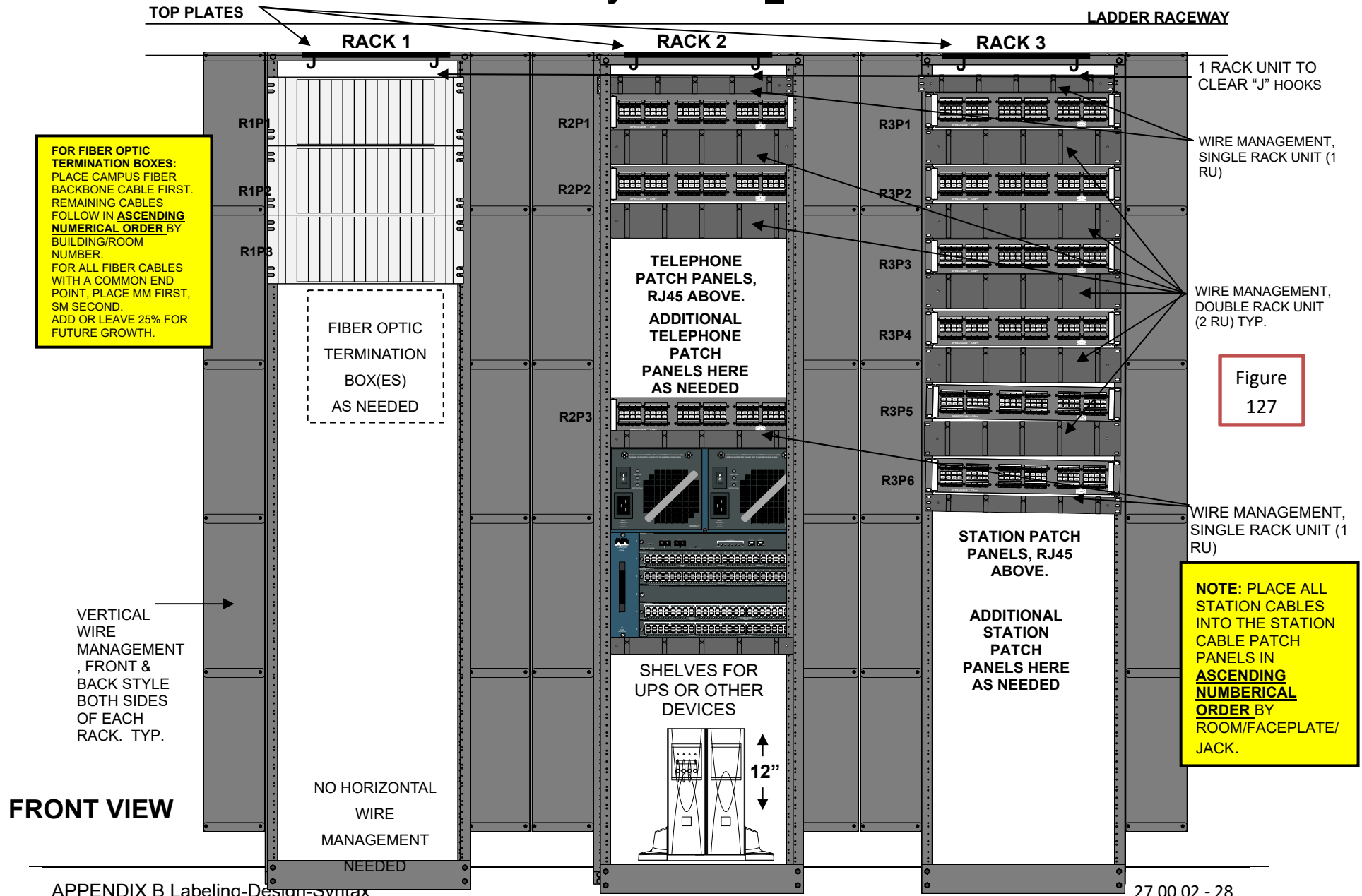

CAMPUS STANDARD POSITIONS OF ITEMS IN TELECOMM RACK

Generic Rack Layout with 4 Racks

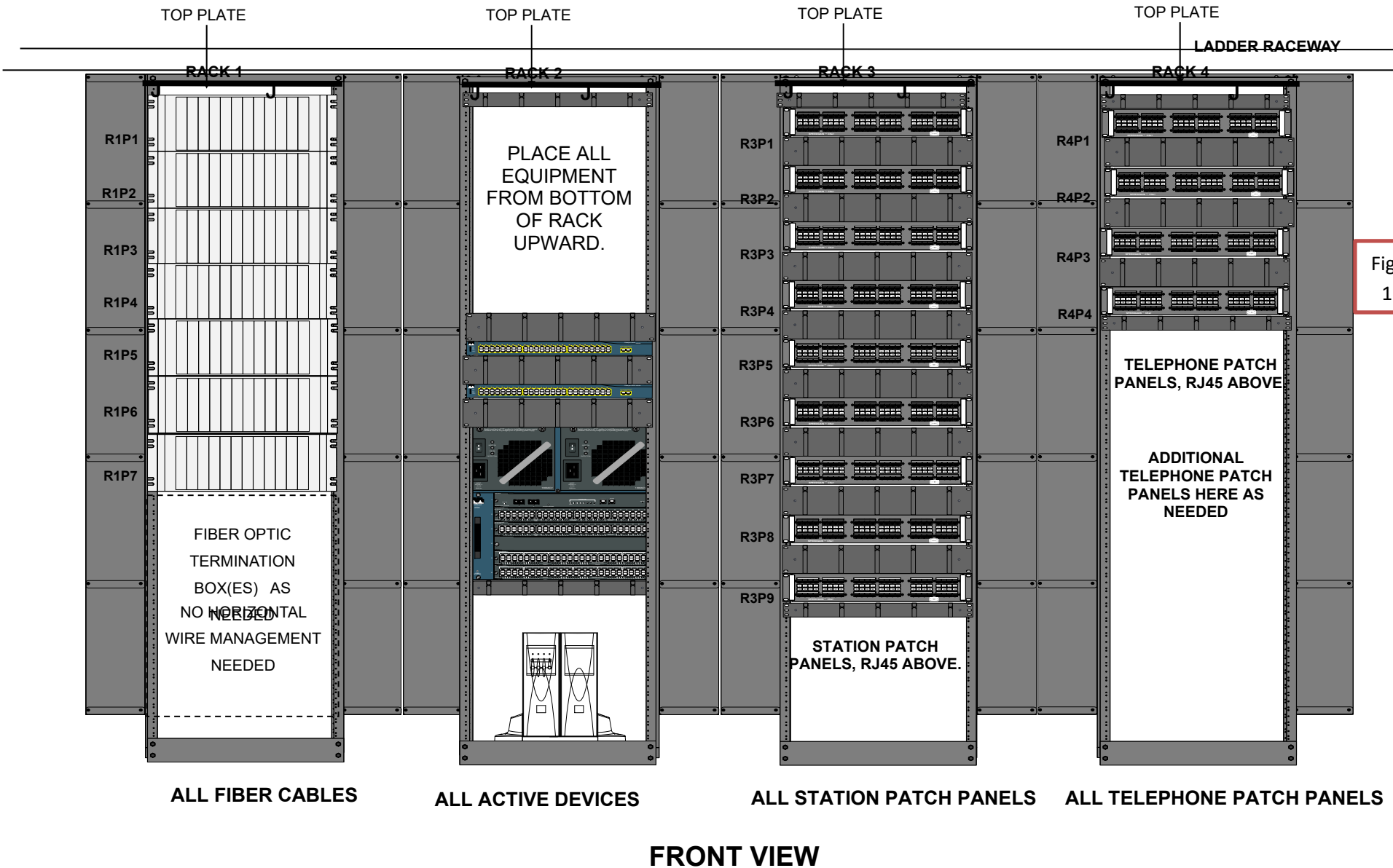

Figure 128

RACK NUMBERING & POSITION IN TELECOMM ROOMS

NUMBER RACKS FROM WALL OUTWARD, AS INDICATED.
ALIGN RACKS WITH LONG AXIS OF RECTANGULAR ROOMS.

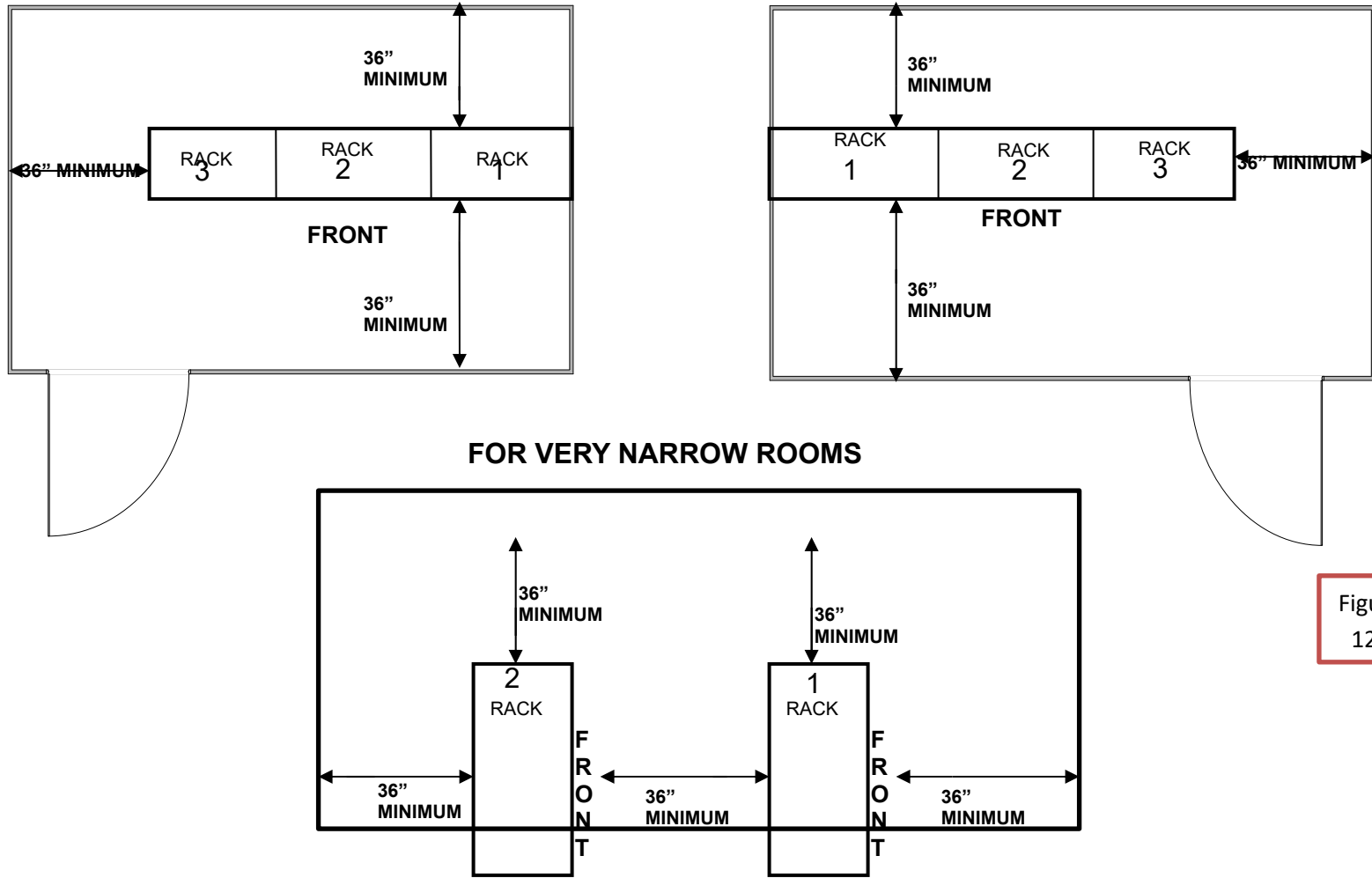
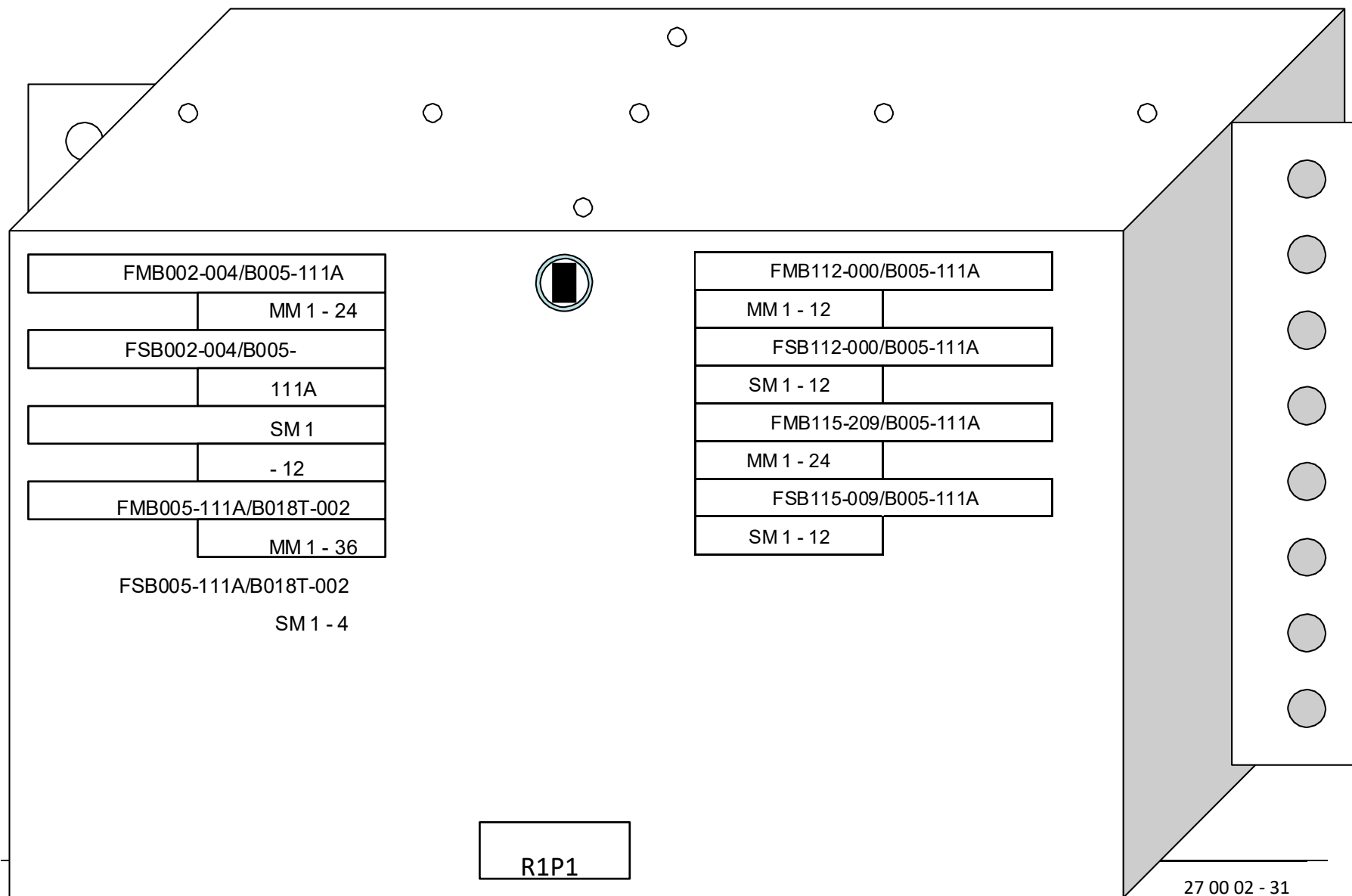

Figure
129

NOTE: THE "FRONT" AND "REAR" 36" DISTANCE RELATES TO THAT OF THE FURTHEST EXTENDING EQUIPMENT

FIGURE 130. FIBER OPTIC CABLE TERMINATION SHELF-EXTERNAL LABELING

Figure
130



**FIBER COLOR - ORDER FOR PATCH PANEL BULKHEAD VARIANTS
BULKHEAD POSITION NOMENCLATURE**

**ITEM 1 - VERTICAL - VEIUED FROM
FRONT**

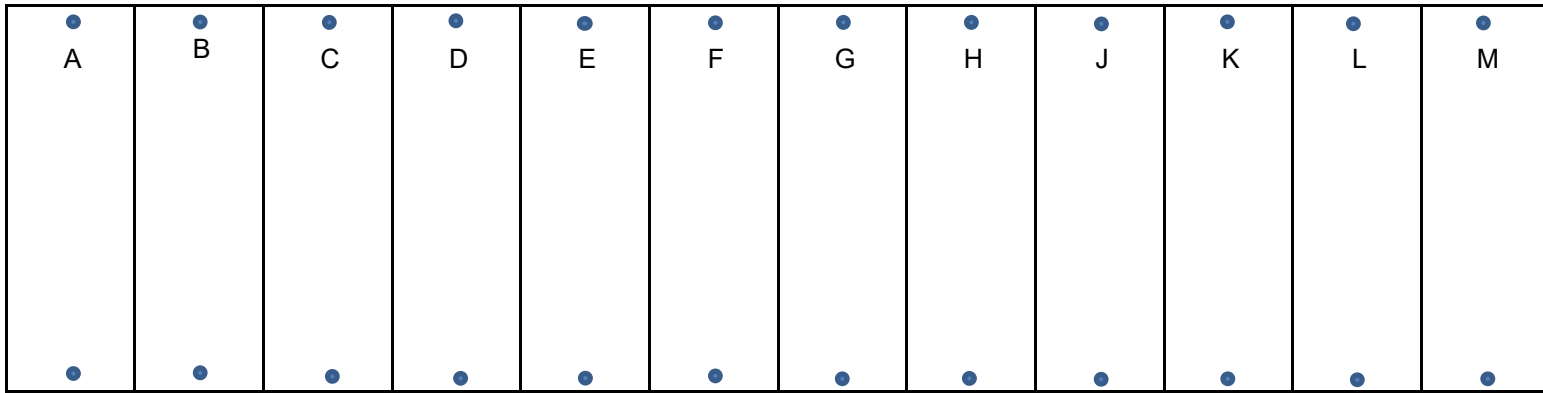

ITEM 2 - HORIZONTAL - VEIUED FROM FRONT



Figure
131

ITEM 3 - HORIZONTAL - VEIUED FROM FRONT

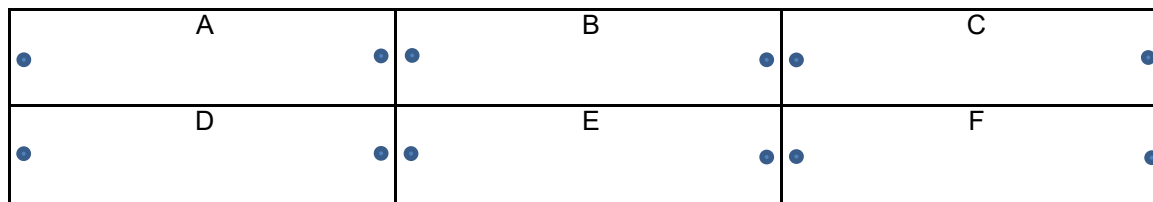



Figure
132

Battery back-up configurations vary. Consult with the Cal Poly ITS Telecomm group for the proper configuration for each project.



Figure
133

Power wiring for equipment installed/mounted in two post racks in every TR/ER shall be mounted to the ladder racking above and to the rear of the racks and done so in such a way as to not block the use of any rack unit locations.



Figure
134

Show is the proper method for providing CATV coax cable for future use.

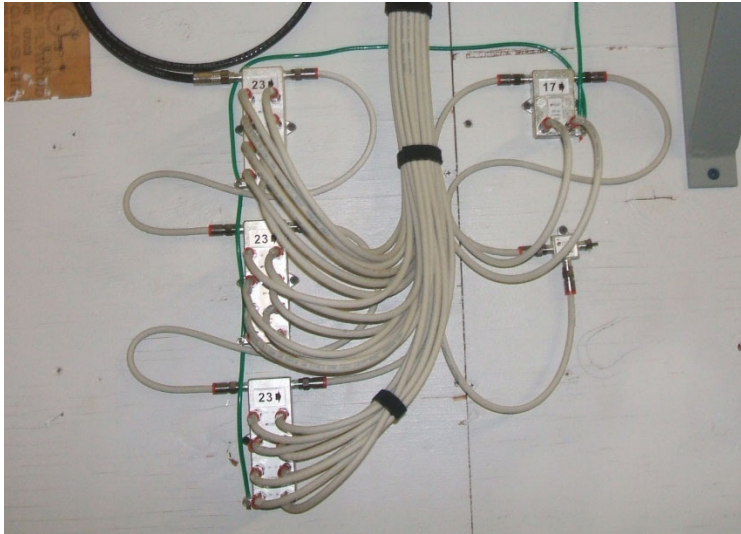

Figure
135

Dress CATV connections neatly on the TR/ER rear wall (opposite the wall containing the telecomm66 “block field”). Be sure to leave an adequate slack loop in every TR/ER.



Figure
136

Seal conduits (including bushings) containing cables properly. Conduits must be re-enterable and where required, sealed using a UL approved methodology to maintain required fire ratings. Non-fire rated sealing shown above.



Figure
137

Seal empty conduits using compression plugs as shown.



Figure
138

Conduits penetrating fire rated walls shall be sealed using materials approved by the State Fire Marshal. Where possible use removable pillows for sealing conduits to make them easier to re-enter if necessary in the future.

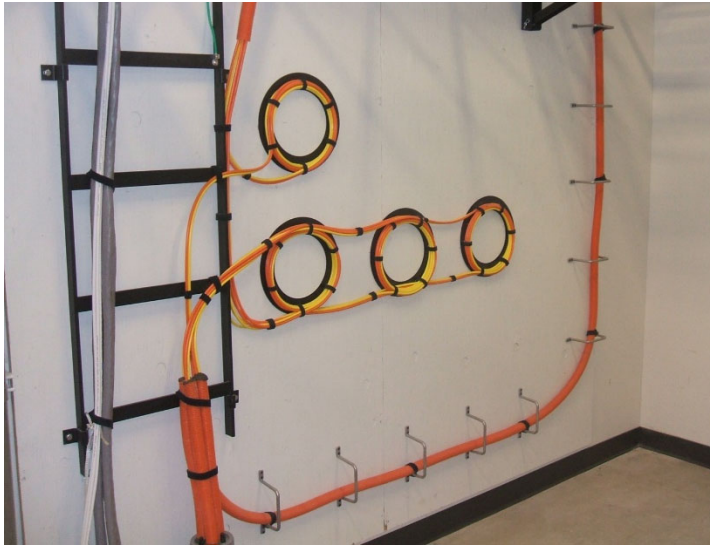

Figure
139

Shown is the proper method for providing fiber optic cable slack loop in a TR/ER.

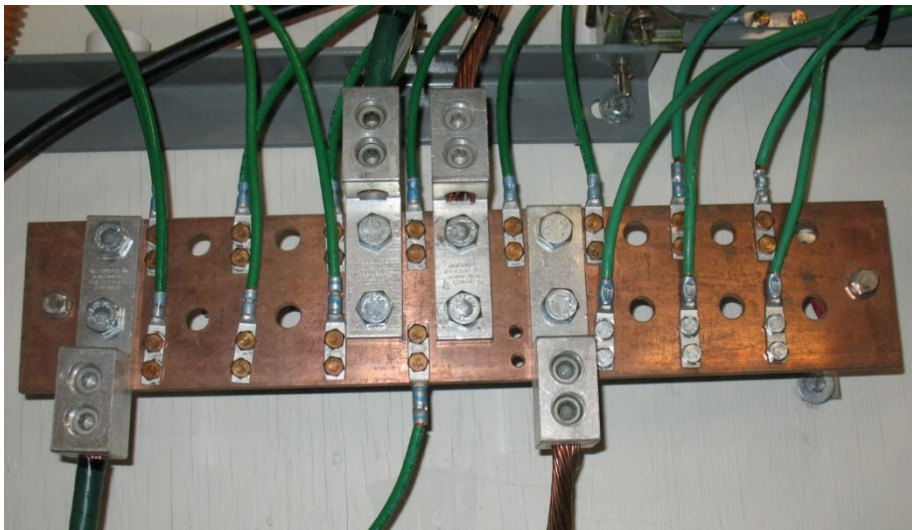

Figure
140

Proper UL Listed grounding busbar. Note that all connections require the use of two-hole mounting lugs. Also note that the large lugs are incorrect and should use crimped-on type lugs to be correct. Use only permanently attached lugs for ground connections.



Figure
141

All ladder racking, cable tray and equipment racks must be properly bonded and grounded. Use star washers on painted surfaces as well as scraping away any paint to assure a good ground connection.



Figure
142

Protectors shall be used any time phone lines leave the drip line of the building and again when they enter their new destination. Protectors must be grounded and bonded using a minimum #6 copper ground wire.



Figure
143

Telephone punch-down, 66 blocks shall be mounted to the back board on the (front) wall across from the front of the equipment racks. The “block-field” wall shall also be across from the (rear) wall containing the CATV connections.

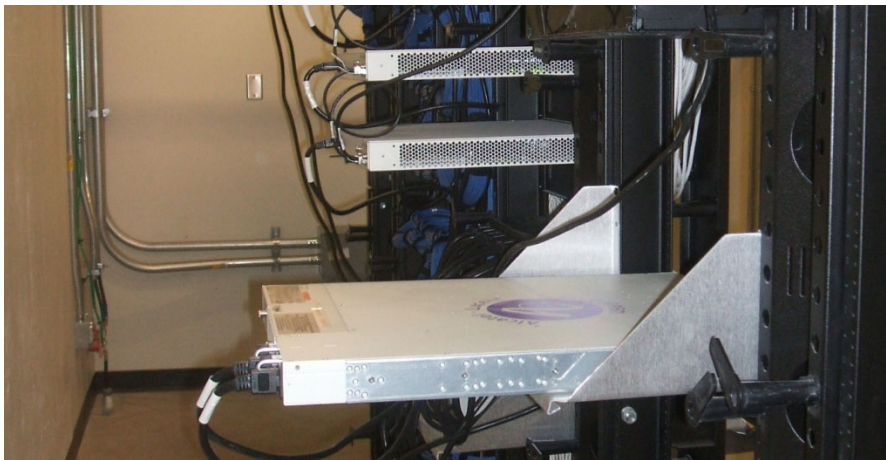

Figure
144

Equipment racks shall be mounted side-by-side in a straight line, starting a minimum of 2” from the nearest wall; be plumb, level and square; and allow a minimum of 36” of clear working space behind and in front all mounted equipment. Racks shall be individually grounded to the grounding buss bar found in each TR/ER.



Figure
145

Equipment racks shall be made of bare aluminum and include 12” of double-sided vertical wire management between racks and 6” double-sided vertical wire management on each end. Covers for the wire management shall also be provided. Ladder rack (18”) shall be installed above all equipment racks.



Figure
146

Back board in the EFs/TRs/ERs shall leave the fire rating stamp visible at all times. The balance of the back board shall be painted with 2 coats of a white paint.

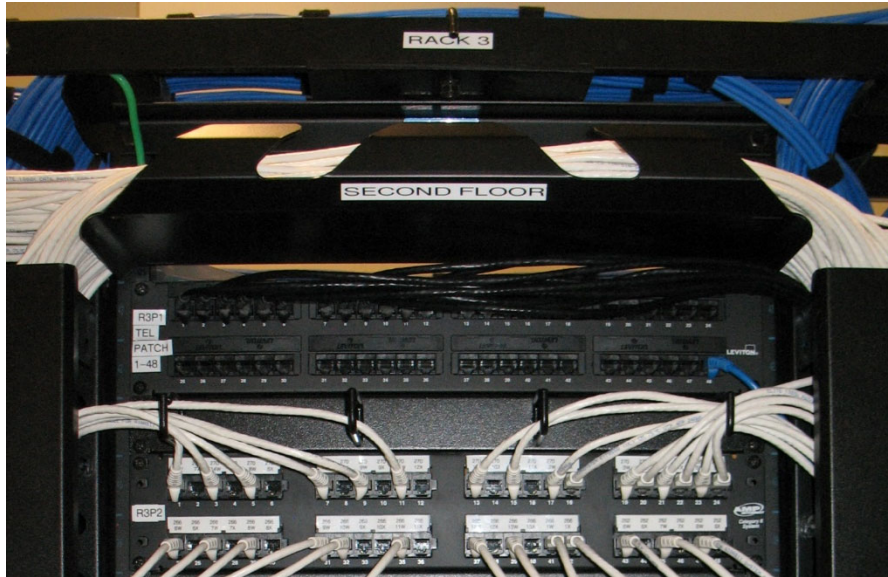

Figure
147

Rack cabinets and patch panels shall be labeled using permanent white labels with black lettering.

Telecomm Room Design Considerations and Requirements

This is the area of the TR/ER that is best suited to house the required telephone protectors. This would be the location where incoming OSP (Outside Plant Cable) is terminated before becoming inside, riser UTP (Unshielded Twisted Pair) used for voice/telephone connectivity within a structure. The protector provides protection against short circuits, voltage spikes and other anomalies that could cause damage to the sensitive electronics that handle today's heavy telephone traffic.

This is the area of the TR/ER that is best suited to house the required "66 block", telephone punch block field. Wiring, coming from the protectors mounted nearby, must be punched down on blocks to mate with wiring that comes from the telecomm patch panels in the equipment racks. Once the phone signal is available at a jack on the patch panel, it can, via a short patch cable, be connected to the structured (CAT 6) patch panel cabling that finally routes the signal to the modular jack on the faceplate in the room where the phone is located.

This is the area of the TR/ER that is best suited to locate the required Telecomm Grounding Busbar (TGB). The busbar assembly is a UL listed assembly to which all telecom, data and CATV equipment and pathways must be connected and which is connected to the Main Telecomm Grounding Busbar (TMGB) in the ER. Bonding together all equipment and pathways creates an entire system at the same ground potential, thereby reducing the possibility of "noise" or ground potential differences that can cause a system to fail or work incorrectly.

This is the area of the TR/ER that is best suited to house CATV equipment and components if required. CATV is provided to a project or building on fiber optic cable. If multiple buildings are involved, the CATV signal will arrive from the "head end" on fiber to an optical splitter where it will be split and forwarded on by fiber to a "fiber node" in the building it will serve. The node converts the information from fiber optic to copper coax cable. In the ER/TR the building's copper based signal is then run through a series of splitters and taps to finally provide the signal that arrives at the "F" connector in the room where TV viewing is desired.

NOTES:

1. Be sure that the equipment compliment for the room is defined so that 3' of clearance can be provided in front and behind the farthest protruding rack mounted equipment.
2. The door must be a minimum of 3' wide and open into a public space (not a living, storage, office or classroom space).
3. Leave a minimum 2" gap between the wall and the first rack (for future cabling).
4. One light fixture (minimum) shall be battery/emergency power backed-up.
5. Power distribution for rack-mounted equipment shall be attached to the ladder racking above the rack (see Figure 133 in Appendix B)

This is the area of the EF/TR/ER that we require the location of conduits (with bushings) entering the EF/TR/ER from the floor/slab. OSP/UTP (CAT 3 twisted-pair) telephone cable will typically be connected/spliced, within a splice case, to ARMM, plenum rated, wiring for distribution throughout the building. The conduits shall enter the room within 3" of the associated wall. As the OSP cabling could be terminated on a protector or spliced and run within the building to the ER, submit shop drawings to the ITS Telecomm group in advance showing the proposed method of CAT 3 cable distribution for approval.

This is the area of the TR/ER that is best suited to house the required electrical power distribution panel that controls all circuits housed within the EF/TR/ER. Never install the panel in the middle of a wall as it will waste too much space. Breakers for the AC unit that cools the room must also be housed in this panel. A close association of the power panel to the entry door allows for easier resetting of a breaker by an electrician, with or without room lighting available.

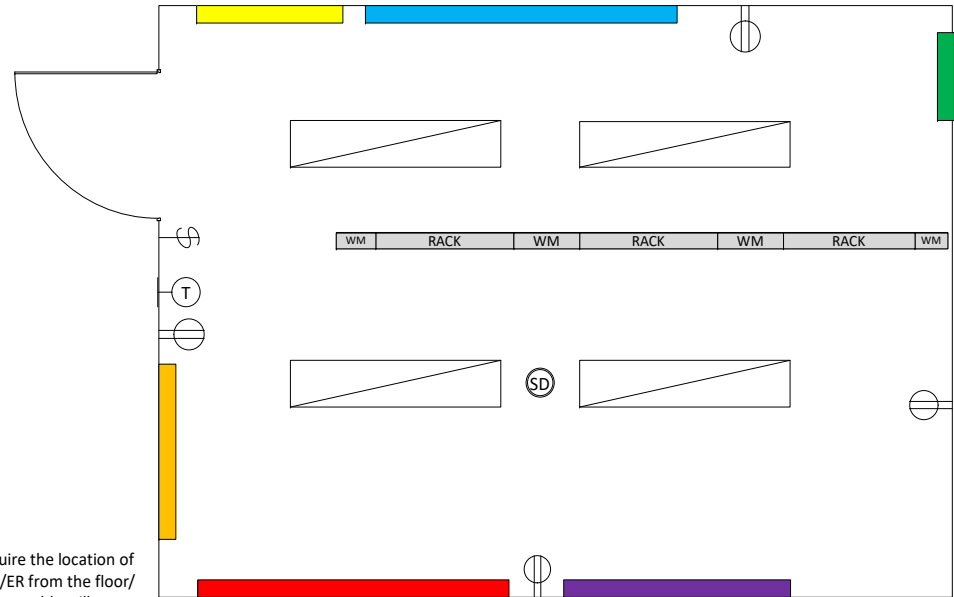

The Design, Construction and Approval Process

When a construction or remodeling project is deemed necessary and the planning process begins, the ITS Telecomm group should be contacted and your communications needs discussed. The CSU System, through the Cal Poly ITS Telecomm group, has the desire and obligation to help you plan for your current and future needs as they pertain to Telecommunications Systems and Services. Technology is constantly changing and the CSU System is mandating changes and equipment refreshes at times and in ways you may not be aware.

The cost of construction is of course important, but the cost of maintaining and servicing is also substantial and on-going. We will work with you to develop a system design and equipment suggestions in the areas of Telephone, Data, CATV, WIFI and Radio Communications Systems that will be cost-effective over the long-term. The earlier we are involved the better and more comprehensive the result will be.

To offer the greatest level of support we can, the Cal Poly ITS Telecomm group has developed a **Telecommunications Standard Document (TCD)** for the Cal Poly Campus. It is the most definitive document describing how to do all things Telecomm on campus. The TCD is available on-line 24/7 at www.calpolyitstelecomm.edu. This 4 page "Cheat Sheet", the Labeling, Design and Syntax Standards, the Campus Building Numbering and Naming Listing and more are available for download or printing at your convenience. The documents and data provided will be used by us to evaluate if the work done meets the developed standards. If you have any questions you can contact **Tech Services** at (805) 756-7315. If we do not hear from you we will assume that you fully understand the expectations and requirements of the CSU System and the Cal Poly ITS Telecomm group.

We look forward to working with you to create the greatest value for all parties.

Figure
148



Figure
149

Provide adequate power in every TR/ER. The power panel shall control all circuits within the TR/ER only. ERs shall have a 225 amp, 208 volt AC, 3 phase power panel and TRs shall have a 125 amp, 208 volt, 3-phase power panel.



Figure
150

Wireless Access Points can usually be mounted indoors vertically on a wall or horizontally on the ceiling. All WAPs are to be labeled in a manner similar to the WAP shown above.



Figure
151

WAPS can be mounted outdoors in a protective, weather-tight enclosure attached to a building.



Figure
152

Code Blue/ Talk-A-Phone phones are typically located in bollards throughout the Campus.



Figure
153

Code Blue/ Talk-A-Phone phones also come in a wall mount version where circumstances require wall mounting.



Figure
154

Building/Project Main Equipment Rooms shall be supported by generator/automatic transfer power backup, systems if available.



Figure
155

Above is a typical “Local” backup generator system using natural gas as a clean fuel source. The generator feeds power to the automatic transfer switch thereby providing emergency power to critical equipment.



Figure
156

Shown is a steel Communications Signal Pull Hole cover provided for the Poly Canyon Village Student Housing Project. This is a sample of the type of manhole cover required for Signal Pull Holes (manholes).



Figure
157

Above is a blowup of the nomenclature style to be used when providing Signal Pull Hole (manholes) covers.

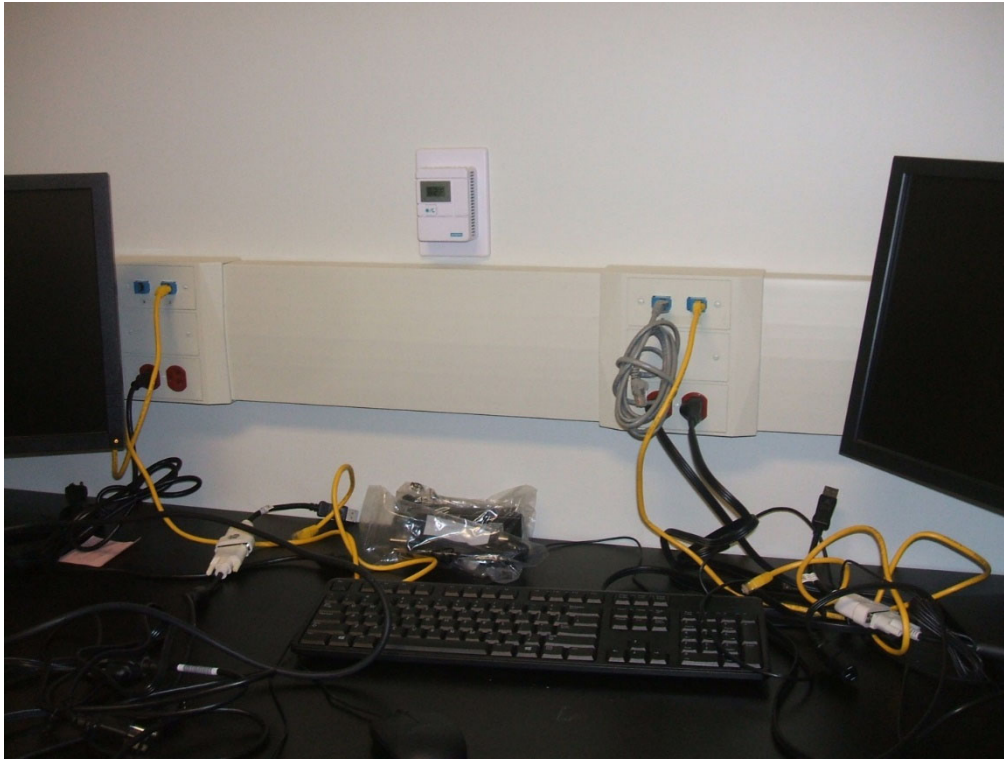
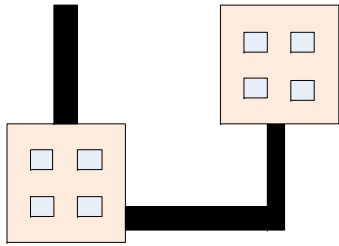

Figure
158

Above is shown Wiremold 4000 Series surface mount raceway as it is typically used in workbench/lab situations.

Figure
159

Daisy Chaining Boxes – Not Allowed



Installing modular jacks in a faceplate and extending additional cable to another back box is not allowed

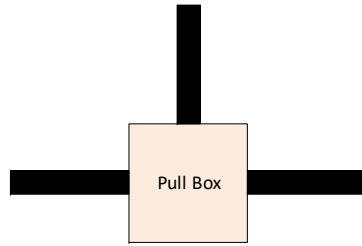

Splitting a bundle of structured cable in a Pull Box is not allowed

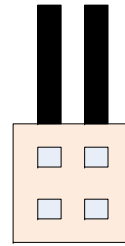

Using a faceplate back box as a pass through pull box for cable to other boxes is not allowed

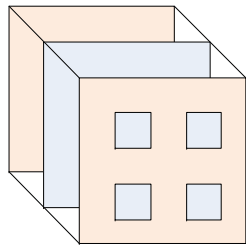

Back-to-Back, "through box" installation, in a wall is not allowed

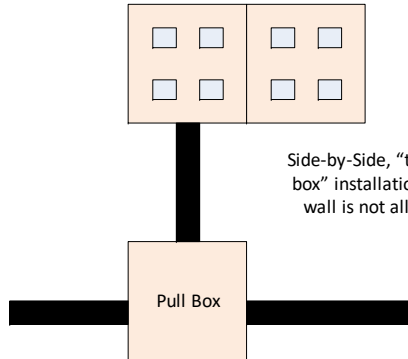

Side-by-Side, "through box" installation, in a wall is not allowed

Notes:
All conduit to be no smaller than 1 1/4"
All back boxes to be no smaller than 4 11/16", 2 1/4" deep

Correct Wiring Method

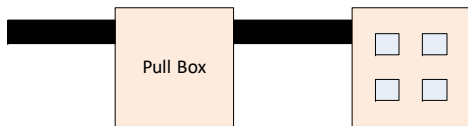

Installing a cable through a Conduit (and if necessary a) Pull Box to a single faceplate Back Box is the only approved method of installing structured cable in a wall

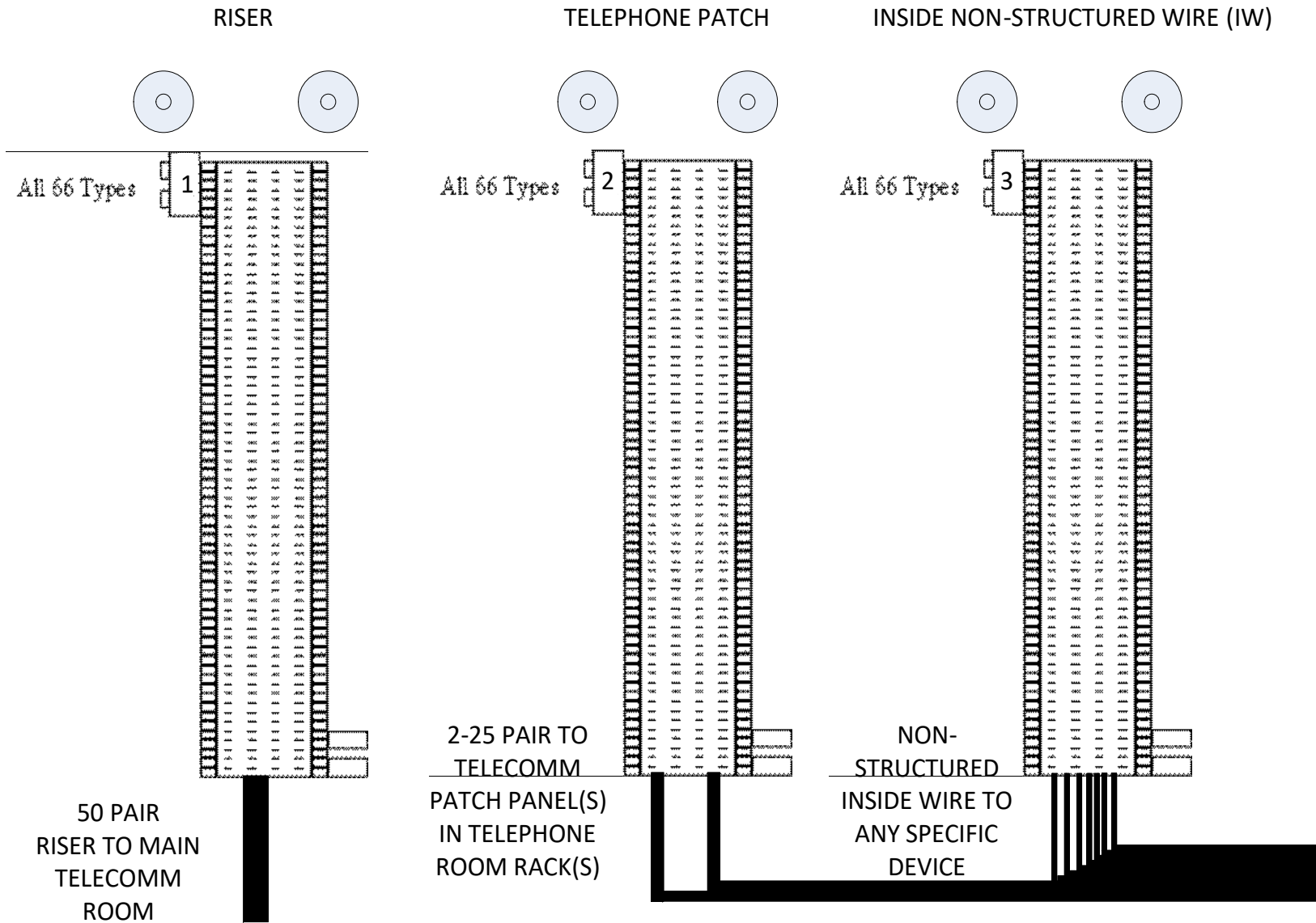
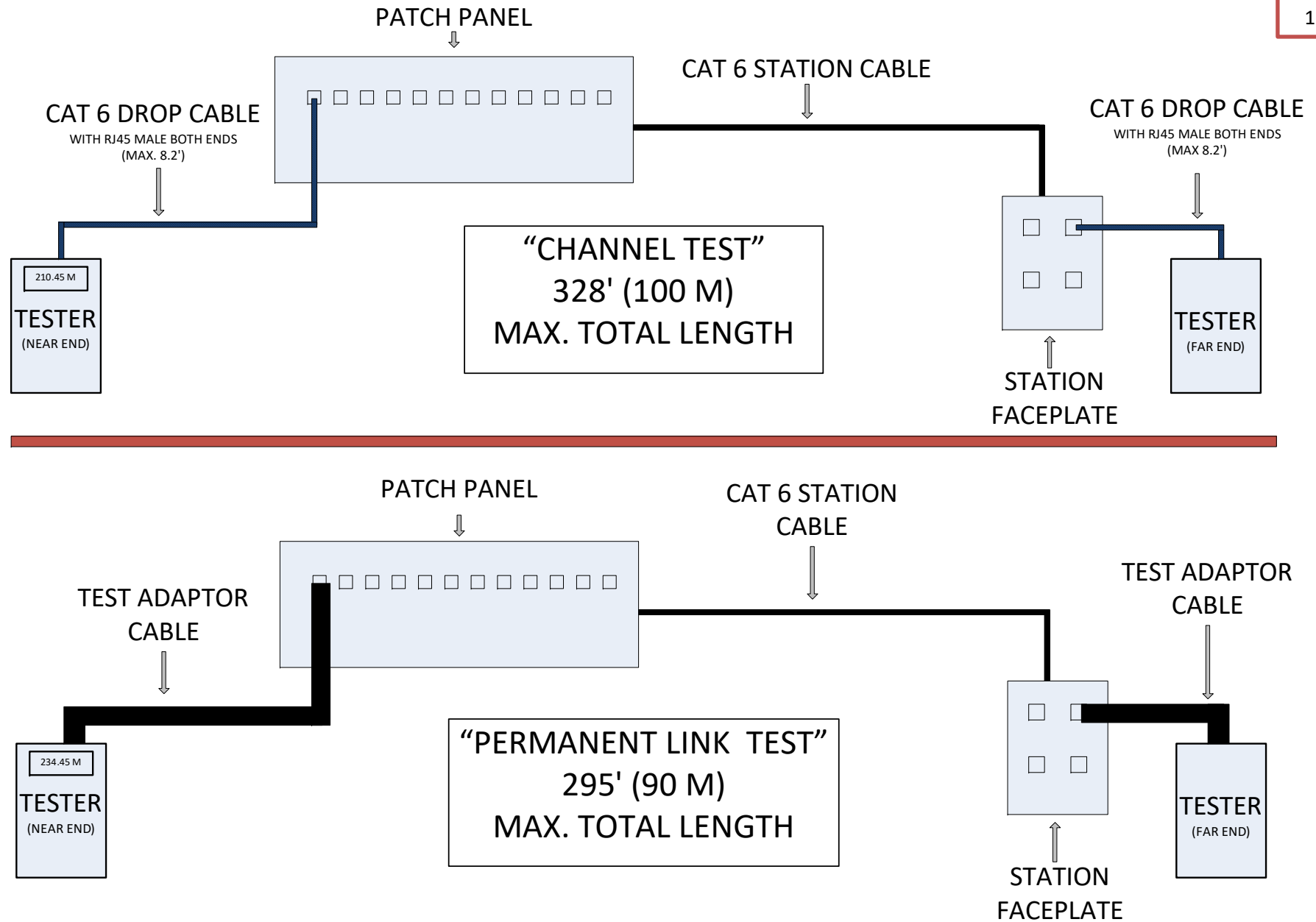

Figure
160

Telecomm back board wiring methodology, typical throughout Campus. Submit shop drawings to the ITS Telecomm group for approval before starting work.

Figure
161



MODE – CONDITIONING CABLE

TOTAL LENGTH – 3 METERS

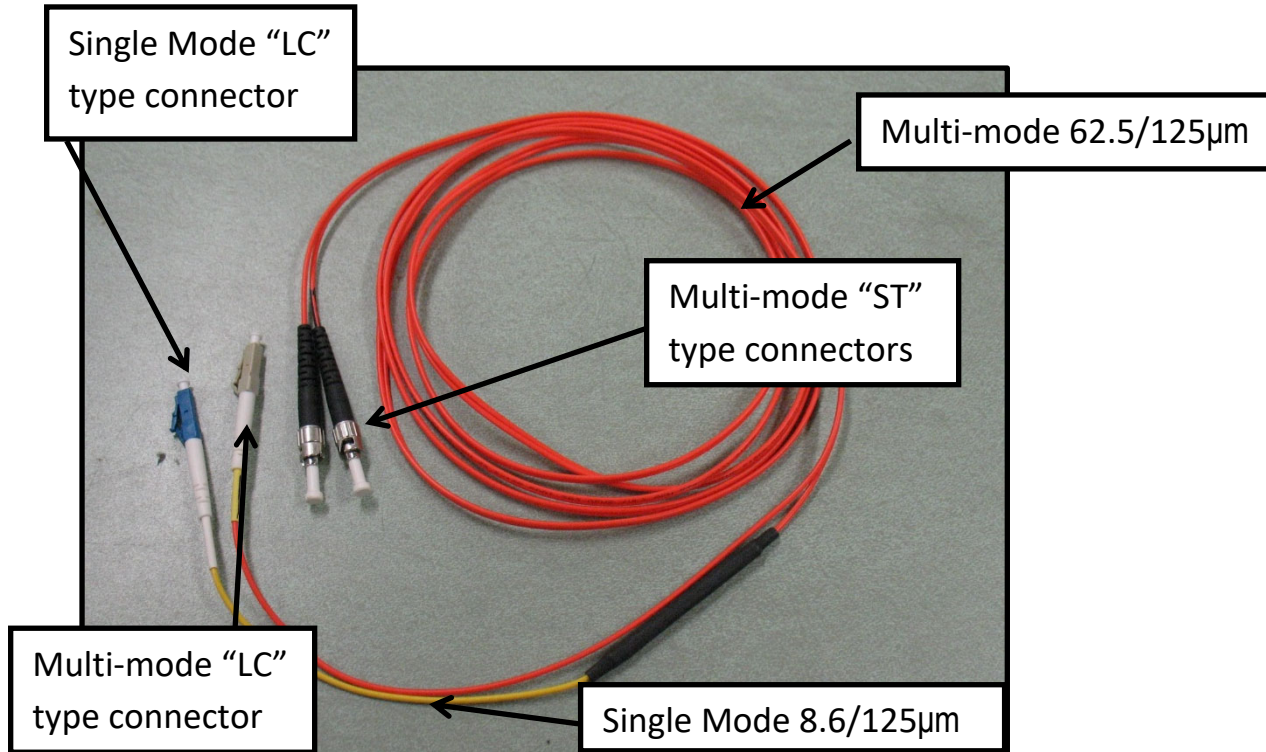

Figure
162

SINGLE-MODE PIGTAILS

Bundle of 12 colors with "SC-upc" connectors & ceramic

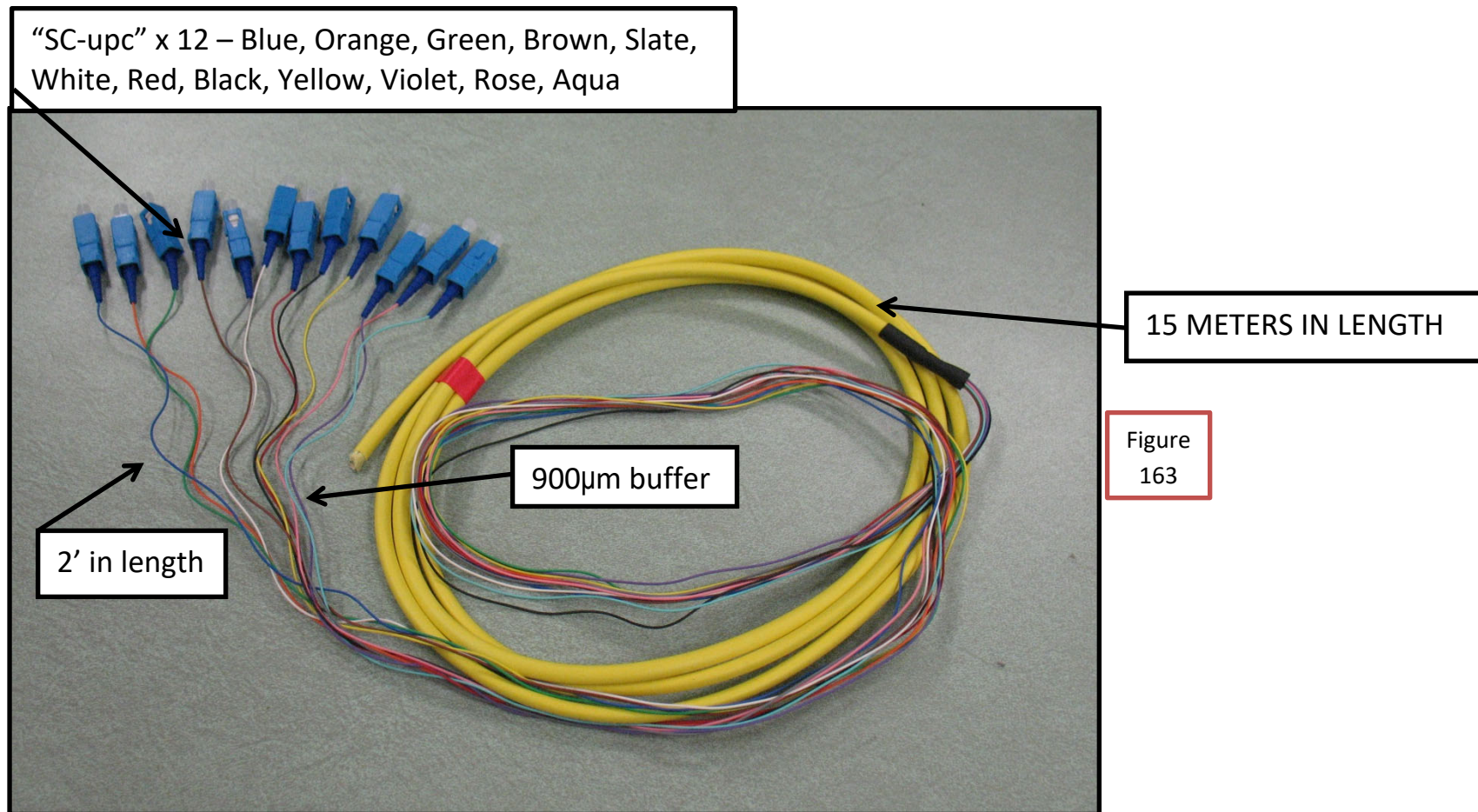



Figure
164

Telecomm Grounding Busbar (TGB) properly terminated using bare ground wire.



Figure
165

Above shows the typical vault hardware to be installed in Telecommunications Manholes (SPHs).



Figure
166

Shown is the proper method for installing a Cal Poly ITS Telecomm network connection in an, exposed hard ceiling, surface mounted, exposed conduit “DEMARK” environment that separates ITS Telecomm wiring/infrastructure from “customer” wiring/infrastructure. This wiring method establishes a way to quickly and easily detach customer wiring/equipment from the Structured Cabling System in an accessible location for the performance of functional testing in event of failure.

**INSTALLING A CUSTOMER OBSTRUCTED NETWORK CONNECTION (DEMARK)
IN A SPACE WITH HUNG CEILING, IN-WALL CONDUITS AND BACK BOXES & AN
INACCESSIBLE USER FACEPLATE FOR DIRECT CONNECTION TO USER EQUIPMENT**

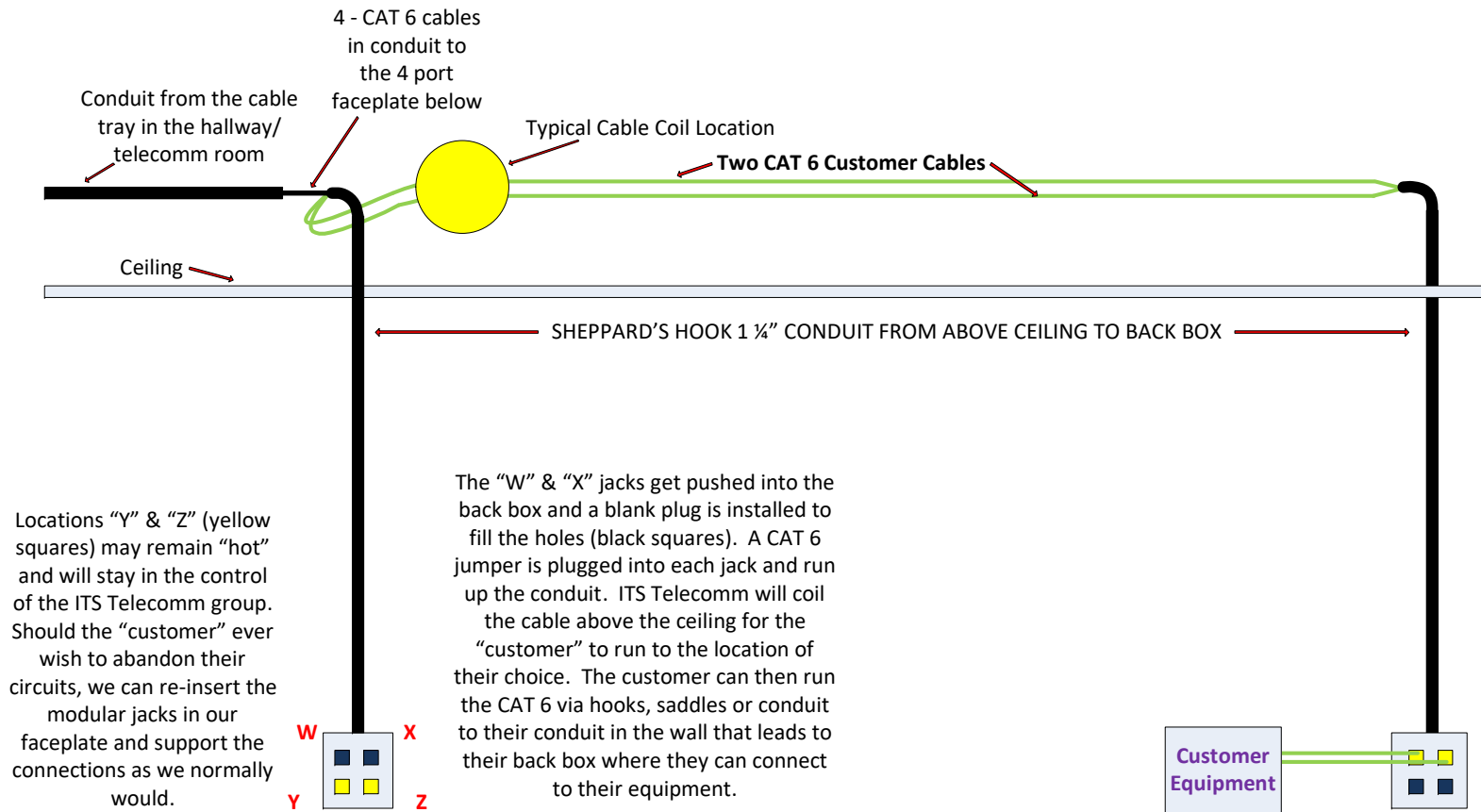

Figure 167



Orange-White
Orange
Brown-White
Brown

Above and below show both sides of a CAT 6 modular jack terminated to the ANSI/TIS-568-C.0 Termination Standard. **The Cal Poly Campus uses the T568A wiring scheme.**

Figure
168



Blue-White
Blue
Green-White
Green

SECTION 27 00 10 – LIST OF DIVISION 27 SECTIONS

PART 1 - GENERAL

1.1 DESCRIPTION

- A. The following is a list of the Division 27 Specification Sections written by the ITS Telecomm group to establish the Telecommunications Standards Document for the California Polytechnic State University, San Luis Obispo.
- B. Section List:

SECTION	DESCRIPTION
27 00 00	Communications – General & Supplemental Terms & Conditions
27 00 02	APPENDIX B Labeling-Design-Syntax
27 00 10	List of Division 27 Sections
27 05 26	Grounding and Bonding for Communications Systems
27 05 33	Conduits and Backboxes for Communications Systems
27 05 36	Cable Trays for Communications Systems
27 05 37	Firestopping Systems for Communications Cabling
27 05 39	Surface Raceways for Communications Systems
27 05 43	Underground Ducts and Raceways for Communications Systems
27 05 53	Identification for Communications Systems
27 06 00	Schedules for Communications
27 08 13	Testing of Copper Cables
27 08 23	Testing of Fiber Optic Cables
27 11 00	Communications Equipment Room Fittings
27 11 13	Communications Entrance Protection
27 11 16	Communications Cabinets, Racks, Frames and Enclosures
27 11 19	Communications Termination Blocks and Patch Panels
27 11 20	Communications Fiber Termination and Patch Panels
27 11 23	Communications Cable Management and Ladder Rack
27 13 13	Communications Copper Backbone Cabling
27 13 14	Communications Copper OSP Cabling
27 13 23	Communications Optical Fiber Backbone Cabling
27 13 24	Communications Optical Fiber OSP Cabling
27 15 13	Structured Cable System
27 15 14	Audio-Visual Station Cables

27 15 23	Fiber Optic Station Cables
27 15 43	Communications Faceplates and Modules
27 20 10	Wireless Access System (WIFI)
27 32 16	Wireless Transceivers (RF/Two-Way Radio)
27 32 26	Emergency Telephones (Blue Phones)
27 40 10	Cable Antenna Television System (CATV)

SECTION 27 05 26 – GROUNDING AND BONDING FOR COMMUNICATIONS SYSTEMS

PART 1 - GENERAL

1.1 DESCRIPTION

- A. The work covered by this section of the Specifications includes all labor necessary to perform and complete such construction, all materials and equipment incorporated or to be incorporated in such construction and all services, facilities, tools and equipment necessary or used to perform a complete installation of the Telecommunications Systems and Components. The work of this section shall include, but is not limited to, the following:
1. Install a telecommunication's grounding and bonding infrastructure.
 2. Grounding shall extend from the vault system to the PBB.
 3. Grounding shall extend from the main building grounding bus bar to the PBB.
 4. Bonding of all ladder rack segments, conduit, pull boxes, junction boxes, equipment racks/frames for use in support of the telecommunications infrastructure. All bonding and grounding shall terminate on the ground bar in the nearest MDF, IDF, or SDF.
 5. Bond all metallic/armored cable sheaths and associated protectors to the ground bars in each MDF, IDF, or SDF.
 6. Bond all Vaults, Signal holes, Pull Holes and Pull Boxes to the common grounding system.
 7. All ground wires shall be terminated using the proper two-hole, compression type, copper lugs

1.2 QUALITY ASSURANCE

- A. Refer to Section 27 00 00 for general details.

1.3 CODES, STANDARDS, AND GUIDELINES

- A. Except as modified by governing codes and by the Contract Documents, comply with the applicable provisions and recommendations in Section 27 00 00.
- B. The University Telecommunication Infrastructure Planning (UTIP) Standards document and section 27 00 02 - APPENDIX B Labeling-Design-Syntax.

1.4 SUBMITTALS

- A. Refer to Section 27 00 00 for general details.
- B. Shop Drawings:
 - 1. Shop drawings shall show the locations where grounding backbone conductors are to be run and where they are to be attached to ground bars (SBB and PBB) within each MDF, IDF, or SDF.
- C. Submit the complete list of materials proposed for this work in accordance with Section 27 00 00.
- D. Submit Manufacturer's Cut Sheets for the following:
 - 1. Any products not specifically listed in the PRODUCTS section shall require a submittal of the manufacturer's cut sheets and approval by the Cal Poly Designated Telecommunications Representative.

1.5 IDENTIFICATION

- A. Each backbone grounding conductor larger than #6 AWG shall be labeled with its far end destination at every instance where it attaches to a ground bar or ground rod. Labels shall be outdoor rated, 1" wide, nylon labels with black lettering at each endpoint and in each manhole or pull box.
- B. Refer to Section 27 05 53 for additional details.

1.6 DEFINITIONS

- A. The Bonding Conductor for Telecommunications (BCT): The BCT shall bond the SBB to the TBB and bond the PBB to the service equipment (building main power) ground.
- B. The Primary Bonding Busbar (PBB): The PBB is usually located in the building MDF and serves as the dedicated extension of the building grounding electrode system for the Telecommunications Systems and Components. The PBB also serves as the central attachment point for telecommunications bonding backbones (TBB) and equipment and is located such that it is accessible to telecommunications personnel.
- C. The Secondary Bonding Busbar (SBB): The SBB is the common central point of connection for telecommunications systems and equipment in the location served by that IDF, or SDF.
- D. The Telecommunications Bonding Backbone (TBB): A TBB is a conductor that interconnects all SBB's with the PBB. A TBB's basic function is to reduce or equalize potential differences between Telecommunications Systems and

Components bonded to it. A TBB is not intended to serve as the only conductor providing a ground fault current return path.

- E. The Telecommunications Bonding Backbone Interconnecting Bonding Conductor (TBBIBC): Whenever two or more vertical TBBs are used within a multistory building, the TBB shall be bonded together with a TBB interconnecting bonding conductor (TBBIBC) at the top floor (at a minimum).

1.7 WARRANTY

- A. Refer to Section 27 00 00 for general

details. PART 2 - PRODUCTS

2.1 PRODUCT CONSISTENCY

- A. Any given item of equipment or material shall be the product of one manufacturer throughout the facility. Multiple manufacturers of any one item will not be permitted.

2.2 APPROVED MANUFACTURERS AND MATERIAL

- A. See Section 27 06 00 – Schedules for Communications for approved manufacturers and material to be supplied for this section.

2.3 METALLIC CABLE SPECIFICATIONS

- A. Ground Wire for Telecommunications Backbone (TBB):
 1. Non-Insulated grounding wire with a minimum conductor size of Number 3/0 AWG copper wire (or as indicated on drawings).
 2. Wire must be UL listed.
- B. Bonding Conductor for Telecommunications (Bonding the SBB to the TBB):
 1. Insulated grounding wire with a minimum conductor size of Number 1/0 AWG copper wire, with PVC insulation.
 2. Must be UL listed.
 3. Cable jacket marking: Must be legible and shall contain the following information:
 - a. Manufacturer's name.
 - b. Copper Conductor Gauge.
 - c. UL listing.
 4. Cable jacket shall be green with black lettering.
- C. Ground Wire for connections within an MDF, IDF, or SDF:

1. Insulated grounding wire with a minimum conductor size of Number 6 AWG copper wire, with PVC insulation.
 2. Must be UL listed.
 3. Cable jacket marking: Must be legible and shall contain the following information:
 - a. Manufacturer's name.
 - b. Copper Conductor Gauge.
 - c. UL listing.
 4. Cable jacket shall be green with black lettering. (See Fig. #140 in 27 00 02 - APPENDIX B Labeling-Design-Syntax)
- D. Ground Wire for connections underground
1. Non-Insulated stranded grounding wire with a minimum conductor size of Number 2 AWG copper wire.
 2. Must be UL listed.
- 2.4 COMPRESSION LUG CONNECTORS
- A. Compression Lug Connector (Attaching #6 AWG ground wire to SBB or PBB):
1. Copper Two-Hole Lug, Straight Long Barrel
 2. 1/4" Bolt Size, 5/8" Hole Spacing
 3. Twin clamping elements for cable; two holes for attachment to grounding bar, cooper viewing hole type lug, etc.
- B. Compression Lug Connector (Attaching #6 AWG ground wire to Conduits, Racks, Cable Runway, Cable Tray, other Grounded Telecom room elements):
1. Copper Two-Hole Lug, Straight Long Barrel
 2. 3/8" Bolt Size,
 3. Twin clamping elements for cable, cooper viewing hole type lug
- C. Compression Lug Connector (Attaching #1/0 AWG or larger ground wire to SBB or PBB):
1. Copper Two-Hole Lug, Straight Long Barrel
 2. 3/8" Bolt Size, 1" Hole Spacing
 3. Twin clamping elements for cable; two holes for attachment to grounding bar, etc.

- D. Compression Lug Connector (Attaching #3/0 AWG or larger ground wire to SBB or PBB):
 - 1. Copper Two-Hole Lug, Straight Long Barrel
 - 2. 3/8" Bolt Size, 1" Hole Spacing
 - 3. Twin clamping elements for cable; two holes for attachment to grounding bar, etc.
- E. Cable to cable connector: Heavy duty, permanent connection by exothermic weld between two or more copper conductors (#2 AWG and larger); splice "T" or cross, as indicated on the drawings and as required.
 - 1. Exothermic welding reusable graphite mold for cable-to-cable connection.

2.5 BUSBARS

- A. PBB (Telecommunications Main Grounding Busbar)
- B. The PBB shall:
 - 1. Be a predrilled copper busbar provided with holes for use with standard sized lugs.
 - 2. Have minimum dimensions of 1/4 in. thick x 4 in. wide x 20 in. long.
 - 3. Be UL listed or by another nationally recognized testing laboratory.
 - 4. Provided with insulators to electrically isolate busbar from mounting surface.
 - 5. Provided with a minimum of 2 in. clearance from wall or other mounting surfaces for access.
 - 6. Have a hole pattern for attaching grounding lugs that meets the requirements of ANSI-J-STD - 607-C and shall accept 27 lugs with 5/8" (15.8 mm) hole centers and 3 lugs with 1" (25.4 mm) hole centers.
- C. SBB (Telecommunications Grounding Busbar)
- D. The SBB shall:
 - 1. Be a predrilled copper busbar provided with holes for use with standard sized lugs.
 - 2. Have minimum dimensions of 1/4 in. thick x 2 in. wide x 12 in. long.
 - 3. Be UL listed or by another nationally recognized testing laboratory.
 - 4. Be provided with insulators to electrically isolate busbar from mounting surface.

5. Be provided with a minimum of 2 in. clearance from wall or other mounting surfaces for access.
6. Have a hole pattern for attaching grounding lugs that meets the requirements of ANSI-J-STD - 607-A and shall accept 15 lugs with 5/8" (15.8 mm) hole centers and 3 lugs with 1" (25.4 mm) hole centers.

2.6 GROUND RODS

- A. Ground Rod (In Underground Vaults & Manholes)
 1. Solid copper clad steel
 2. 3/4" diameter by 10' length
- B. Ground Rod (In Underground Pull Holes & Pull Boxes)
 1. Solid copper clad steel
 2. 5/8" diameter by 8' length
- C. Ground Rod Attachment
 1. Exothermic welding reusable graphite mold for cable-to-ground rod connection.
 2. Terminate cable to ground rod, #2 AWG to rod

3/4" PART 3- EXECUTION

3.1 GENERAL

- A. The Contractor shall install each ground conductor (wire) as an uninterrupted conductor section between the designated termination points, unless otherwise directed by the installation specifications. There shall be no splices or mechanical couplers installed between the wire points of origin and termination except as shown on the Drawings and/or specified herein.
- B. Unless otherwise noted, all ground wires shall be routed through the telecommunications cable management pathways so as to achieve a "coupled bonding conductor" effect.
- C. Do not install ground bars until after their installation location has been approved by the Cal Poly Designated Telecommunications Representative.

3.2 QUANTITIES

- A. Quantities of ground wires, bonding components, etc. shown on the drawings are illustrative only and are meant to indicate the general configuration of the work. The Contractor is responsible for providing the correct quantities of materials to construct a grounding and bonding system that meets the intent

of these Specifications and the relevant codes.

3.3 INSTALLATION

A. Cable & Wire Installation

1. Required Grounding Connections:

- a. Provide and install one individual #6 AWG ground wire from each equipment rack/frame (installed under this work) to the SBB in the room. Each conductor is to be "home run"; do not "daisy chain" the connections, unless specifically indicated on the drawings.
- b. Provide and install one individual #6 AWG ground wire from the overhead cable runway (installed under this work) to the SBB in the MDF, IDF, or SDF.
- c. Install one individual #6 AWG ground to each cable tray entering the MDF, IDF, or SDF.
- d. Install one individual #6 AWG ground to each cable shielded termination. Install one individual #6 AWG ground to each entrance protector.
- e. Install one individual #6 AWG ground to each metal conduit or sleeve.

B. Busbar Installation

1. Wall-Mount Busbars

- a. Attach busbar to the wall with appropriate hardware according to the Manufacturer's installation instructions.
- b. Conductor connections to the PBB or SBB shall be made with two-hole bolt-on compression lugs, with lock washers, sized to fit the busbar and the conductors.
- c. The Wall-Mount Busbar assembly shall be mounted @ 18" AFF, on the wall perpendicular to the rack row farthest from the entry door and close to or in a corner. (See the Fig. # 148 in 27 00 02 - APPENDIX B Labeling-Design-Syntax)

C. Ground Terminal Block

- a. Every rack and cabinet shall be separately bonded to the PBB or SBB.
- b. Minimum bonding connection to racks and cabinets shall be made with a rack-mount two-hole ground terminal block sized to fit the conductor and rack, installed on the rear of the rack, at the top,

according to manufacturer recommendations.

- c. Remove paint between rack/cabinet and terminal block, clean surface and use antioxidant between the rack and the terminal block to help prevent corrosion at the bond.

3.4 GROUNDING AND BONDING

- A. See appropriate sections of this document for details.

3.5 TESTING

- A. The Contractor shall test all metallic wires and cables installed under these Specifications.
- B. Using a multimeter, test continuity of each system element to ground (SBB or PBB) for a maximum resistance of 1Ω (Ohm).

3.6 ACCEPTANCE

- A. Upon receipt of the Contractor's documentation of testing, the Cal Poly Designated Telecommunications Representative will review/observe the installation and may randomly request tests of the cables/wires installed. Once the testing has been completed and the Cal Poly Designated Telecommunications Representative is satisfied that all work is in accordance with the Contract Documents, the representative will notify the Contractor and/or the Cal Poly Facilities Project Manager in writing or via email.

3.7 RECORD (AS-BUILT) DRAWINGS

- A. The Project Record Drawings shall show the types and locations of installed grounding and bonding conductors.

END OF SECTION

SECTION 27 05 33 – CONDUITS AND BACKBOXES FOR COMMUNICATIONS SYSTEMS

PART 1 - GENERAL

1.1 DESCRIPTION

A. The work covered by this section of the Specifications includes all labor necessary to perform and complete such construction, all materials and equipment incorporated or to be incorporated in such construction and all services, facilities, tools and equipment necessary or used to perform a complete installation of the Telecommunications Systems and Components. The work of this section shall include, but is not limited to, the following:

B. Conduit and boxes in accordance with the Contract Documents.

1.2 QUALITY ASSURANCE

A. Refer to Section 27 00 00 for general details.

1.3 CODES, STANDARDS, AND GUIDELINES

A. Except as modified by governing codes and by the Contract Documents, comply with the applicable provisions and recommendations in Section 27 00 00.

B. The University Telecommunication Infrastructure Planning (UTIP) Standards document and section 27 00 02 - APPENDIX B Labeling-Design-Syntax.

1.4 SUBMITTALS

A. Refer to Section 27 00 00 for general details.

B. Shop Drawings:

1. Coordinated conduit layout drawings, 1/8" scale, minimum. Show routing of all telecommunications conduits.
2. Show locations of all telecommunications pull or termination (faceplate) back boxes and include faceplate IDs.

C. Submit Manufacturer's Cut Sheets for the following:

1. Any products not specifically listed in the PRODUCTS section shall require a submittal of the manufacturer's cut sheets and approval by the Cal Poly Designated Telecommunications Representative.

1.5 IDENTIFICATION

- A. Label both ends of any conduit 2" or larger noting destination.
- B. Refer to Section 27 05 53 for additional details.

1.6 DEFINITIONS

- A. All conduit and pull boxes shall be sized to allow for a future cable plant expansion of 60%.
- B. All pathways are to be continuous, accessible, viable and useable upon completion of construction.
- C. All pathways shall have no more than (2) 90-degree bends without a pull point
- D. Minimum conduit size for communications conduit is 1 ¼ ".

1.7 WARRANTY

- A. Refer to Section 27 00 00 for general

details. PART 2 - PRODUCTS

2.1 PRODUCT CONSISTENCY

- A. Any given item of equipment or material shall be the product of one manufacturer throughout the facility. Multiple manufacturers of any one item will not be permitted.

2.2 APPROVED MANUFACTURERS AND MATERIAL

- A. See Section 27 06 00 – Schedules for Communications for approved manufacturers and material to be supplied for this section.

2.3 CONDUIT AND FITTINGS (with bushings on all ends)

- A. Rigid Metal Conduit (RMC):
 - 1. Rigid conduit, heavy wall, threaded ends.
 - 2. Threaded type fittings.
- B. Intermediate Metallic Conduit (IMC):
 - 1. Rigid conduit, thinner wall, threaded ends.
 - 2. Threaded type fittings.
- C. Electrical Metallic Tubing (EMT):
 - 1. Continuous, seamless steel tubing galvanized or sherardized on exterior, coated on interior with smooth hard finish of lacquer, varnish or enamel.
 - 2. Steel, set screw or compression type fittings. Provide concrete type fittings where required.

- D. Rigid Non-metallic Conduit (PVC):
 - 1. Schedule 40 polyvinyl chloride suitable for 90° C.
 - 2. Solvent cemented type fittings.
- E. Insulated Grounding Bushings for Rigid Metal Conduit and Intermediate Metallic Conduit and Electrical Metallic Tubing:
 - 1. Shall be constructed of malleable iron.
 - 2. Shall have a plastic insulated throat.
 - 3. Shall have set screws.
 - 4. Shall have a bronze lay-in type lug.
- F. Fittings for Threadless Rigid Metal Conduit (RMC) or Intermediate Metallic Conduit (IMC):
 - 1. Shall be constructed of malleable iron, zinc plated.
 - 2. Shall have a plastic insulated throat.
 - 3. Shall be compression type.
 - 4. Shall be UL listed water and concrete tight.
- G. Fittings for Electrical Metallic Tubing (EMT):
 - 1. Shall be constructed of steel, zinc plated.
 - 2. Shall have a plastic insulated throat.
 - 3. Shall be compression type.
 - 4. Shall be UL listed water and concrete tight.

2.4 BACK AND PULL BOXES

- A. Cast Type Boxes (Weatherproof, Surface mount):
 - 1. Universal Box with mounting lugs, two closure plugs and ground screw.
 - 2. Tapered threads for hubs.
 - 3. Material-Die Cast Aluminum with Aluminum lacquer finish.
- B. Cast Type Box Cover (Weatherproof, Surface mount):
 - 1. Cast raised cover; size matched to contour of box.
- C. Galvanized Pressed Steel Type Boxes (Indoor Station Back Boxes):
 - 1. Pressed steel, galvanized or cadmium-plated.
 - 2. 4-11/16" square by 2-1/8" deep minimum with 1-1/4" knock out.

- D. Mud Ring for Galvanized Pressed Steel Type Boxes (Indoor Station Back Boxes w/ 6 or less data outlets):
 - 1. 4-11/16" Pre-galvanized steel square box device cover, 5/8" raised, 3 cu in.
- E. Mud Ring for Galvanized Pressed Steel Type Boxes (Indoor Station Back Boxes w up to 8 data outlets):
 - 1. 4-11/16" Pre-galvanized steel square box device cover, 5/8" raised, 6.3 cu in.
- F. Sheet Steel Boxes (Pull Boxes):
 - 1. No. 12 gauge sheet steel for boxes with maximum side less than 40 inches, and maximum area not exceeding 1,000 square inches; riveted or welded 3/4" flanges at exterior corners.
 - 2. No. 10 gauge sheet steel for boxes with maximum side 40 to 60 inches, and maximum area 1,000 to 1,500 square inches; riveted or welded 3/4" flanges at exterior corners, with hinged covers if clearance allows.
 - 3. No. 10 gauge sheet steel riveted or welded to 1-1/2" by 1-1/2" by 1/4" welded angle iron framework for boxes with maximum side exceeding 60 inches and more than 1,500 square inches in area, with hinged covers if clearance allows.
 - 4. Covers:
 - a. Same gauge steel as box.
 - b. Hinged covers if clearance allows else subdivided single covers so no section of cover exceeds 50 pounds.
 - c. Machine bolts or machine screws threaded into tapped holes.
 - 5. Paint:
 - a. Rust inhibiting primer, ANSI 61 grey enamel finish coat.
 - b. Manufacturer/Product: None Specified - Make Submittal

2.5 FLOOR BOXES AND FITTINGS

- A. Recessed Floor Box:
 - 1. Floor boxes and fittings shall be suitable for the fire rating and thickness of the floor and for the types and quantity of telecommunications Structured Cabling System to be installed through the device.
 - 2. Lid or cover must have the ability to close completely while allowing cables to exit the box without compression or damage.
 - 3. See Section 27 15 43 for additional detail.

4. Each box shall have a minimum of one 1-¼" knock out.

2.6 INNERDUCT

A. Outside Plant Innerduct

1. 1-¼" Single Fiber Smooth Wall Innerduct (For 4" OSP Conduit, 4 required).
2. Orange in color.
3. Mule tape required in each innerduct.

B. Fiber Optic Innerduct

1. 1-¼" Single Fiber Smooth Wall Innerduct (For 4" OSP Conduit, 4 required).
2. Orange in color.
3. Mule tape required in each

innerduct. PART 3- EXECUTION

3.1 GENERAL

- A. Provide conduit and pull boxes for all telecommunications cabling routed outside of each MDF, IDF, or SDF. All conduit and pull boxes leaving the MDF, IDF, SDF shall be sized to include an additional 25% capacity for future expansion (e.g 15% max fill)
- B. No cable hangers (J-Hooks, Bridle Rings, Bat Wings, Etc.) shall be used. Exceptions for special use in an accessible space (limited lateral runs < 15 feet and cable counts < 9 cables) shall be approved by the Cal Poly Designated Telecommunications Representative.
- C. Horizontal pathways shall follow building lines and shall be accessible for future for reentry.
- D. All pathways shall be firestopped with re-enterable firestopping at rated assemblies. Exceptions shall be approved by the Cal Poly Designated Telecommunications Representative and AHJ.
- E. All pathways entering or leaving a MDF, IDF, or SDF shall be firestopped with re- enterable firestopping at rated assemblies.
- F. Locate conduits so that the integrity of structural members is not affected, and they do not conflict with the services of other trades.
- G. Except where other specific sizes are required by the Contract Documents, the minimum size for telecommunications conduits shall be:
 1. Four - 4" conduits for backbone pathways. 4" conduits shall also be used

between the MDF and each IDF or SDF on the same floor of a multi-story building.

2. One - 1-1/4" where a conduit serves a maximum of one typical faceplate.

H. CONDUIT FILL

1. Maximum cable count in conduit (conduit fill) to avoid exceeding maximum pull tension limitations.
2. See "Conduit Fill (4 pair UTP, plenum rated)" in the UTIP standard.

3.2 QUANTITIES

- A. Quantities of conduits, pull boxes, etc. shown on the drawings shall be illustrative only and are meant to indicate the general configuration of the work. The Contractor shall be responsible for providing the correct quantities of materials to construct a system that meets the intent of these Specifications and the relevant codes.

3.3 INSTALLATION

A. Conduit

1. Where accessible cable tray is installed, conduit must extend continuously to and must mechanically attach, or be bonded to, the cable tray.
2. Conduit must extend no further than 2 inches into the cable tray.
3. All conduits are to have insulated throat bushings.
4. Throat bushings shall have grounding lugs unless mechanically attached to cable tray.
5. All conduits are to be continuously bonded back to the PBB in the MDF, IDF, or SDF.
6. Draw up couplings and fittings full and tight. Protect threads from corrosion after installation with zinc chromate or equivalent protection.
7. Conceal conduits except at surface mounted cabinets and freestanding equipment. Install minimum of 6 inches from flues, steam pipes, or other heated lines. Provide flashing and counter-flashing for waterproofing of raceways that penetrate the roof. Do not penetrate waterproof membranes unless proper seal is provided, and permission is given by the Cal Poly Designated Telecommunications Representative.

8. Install telecommunications conduit a minimum of 24 inches from parallel power raceways; avoid long parallel runs of telecommunications and power conduits to the extent practicable. When crossing power raceways, cross at a 90 degree angle.
 9. Install telecommunications conduit a minimum of 12 inches from florescent lighting fixtures.
 10. Route exposed conduits and conduits above suspended ceilings parallel or perpendicular to building lines with right angle turns and symmetrical bends. Provide sleeves in concrete walls, floor slabs and partitions. Waterproof sleeved conduits where required.
 11. Provide conduit expansion joints for exposed and concealed conduits at expansion joints between structures to compensate for differential movement and where necessary to compensate for thermal expansion/contraction. Provide bonding conductor.
 12. Provide conduit seal-offs where portions of an interior raceway system pass through walls, ceilings or floors which separate adjacent rooms having substantially different maintained temperatures, refrigeration, or being used as cold storage rooms.
 13. Provide conduit seal-offs where portions of an exterior raceway system pass into a building.
 14. Conduit seals shall be vapor proof.
 15. Provide ¼" nylon pull rope with 600 lb. pulling tension in every conduit 2" or larger.
 16. Provide pull string with 210 lb. pulling tension in every conduit smaller than 2".
 17. All conduits must have a pull string/rope, including after placement of cabling.
 18. Secure conduit clamps or supports to masonry materials with toggle bolts, expansion bolts, or steel inserts. Install conduit on steel construction with approved clamps which do not depend on friction or set-screw pressure alone.
 19. The minimum 90-degree bend radius for conduit is 6 times the internal diameter of the conduit (10 times the internal diameter if conduit larger than 2 inches).
- B. Conduit above Suspended Ceilings
1. Provide independent support of all conduits. Provide UNISTRUT

support and threaded rod to structure above. Attachment to ceiling support wires is not permitted.

2. Install conduit a minimum of 12" above top of suspended ceiling.

C. Conduit in floor slabs

1. Conduits runs for horizontal cabling shall not be installed below a building's slab; however, they may be installed within the slab with the approval of the Structural Engineer and the Cal Poly Designated Telecommunications Representative.
2. Conduits shall not interfere with placement of floor slab reinforcement components.
3. Install conduits between the upper and the lower layers of reinforcing steel.
4. Space conduits not less than 8" on centers except where they converge at telecommunications backboards, equipment cabinets or junction boxes.
5. Conduits running parallel to slabs supports, such as beams, columns, and structural walls, shall be installed not less than 12" from such supporting elements.
6. Elbows used for stub ups on conduit installed below grade or embedded within floor slabs shall be rigid steel conduit with two coats of corrosion resistant paint or tape wrap.
7. Tie embedded conduits securely in place prior to concrete placement. Conduits installed within floor slabs shall extend a minimum of 3" above the finished slab to a maximum of 6" above the finished slab.
8. Conduits embedded in a slab and then continuing on to another destination shall have a dedicated pull box within 1' of their stub up.
9. Pathways embedded below the slab must be continuous from the faceplate location to the MDF, IDF, or SDF.

D. Conduit in hazardous locations

1. Provide conduit with appropriate seal-offs, explosion-proof fittings, etc. in special occupancy areas as required.
2. Conduits and fittings installed in hazardous (classified) locations shall conform to NEC Article 500 requirements for the associated Class and Division.

E. Non-Metallic Conduit

1. Not used. Proposed use case would require submittal and approval.
2. Joints shall be made using the material recommended by the conduit manufacturer. Components shall be cleaned prior to assembly.
3. Conduit cutoffs shall be square and shall not deform conduit. Ream rough surfaces.
4. Provide male box adapters to terminate conduits.
5. Where separable terminations are required, provide PVC threaded adapters with locknuts or bushings. Provide "O" rings for watertight installations.
6. All bends must be factory manufactured.
7. Provide expansion fittings where required.
8. Conduit supports shall be installed to allow non-metallic conduit to slide through the supports.

F. Back-Boxes

1. Provide back boxes and pull boxes as indicated and as required for a complete installation and to facilitate proper pulling of wires and cables.
2. Boxes shall be sized per ANSI/TIA/EIA-569-A as minimum. (For single conduits trade size 1-1/4 inch, or smaller, a back-box sized 4-11/16" square by 2-1/4" deep may be used as a pull box, UON.) Plug open knock outs.
3. The exact location of back boxes and equipment is governed by field conditions. Where necessary, relocate back boxes so that fixtures and equipment are symmetrically located in accordance with the room layout and will not interfere with other work or equipment. Verify final location of back boxes, fixtures, and equipment with Architect and the Cal Poly Designated Telecommunications Representative.
4. Back-to-back back boxes in the same wall, or "through-wall" type boxes are not permitted. (See Fig. #159 in 27 00 02 - APPENDIX B Labeling-Design-Syntax)
5. Fit back boxes in finished ceilings or wall with appropriate covers, set flush with the finished surface. Provide box with tile ring in masonry walls not plastered or furred. Where drywall material is utilized, provide a plaster ring.

G. Pull Boxes

1. Pull boxes shown in the Drawings are generally a minimum requirement that

assumes the conduit run shall be the length indicated and there shall be no more bends than indicated. Actual site conditions and field coordination with other trades usually result in additional bends in the conduit and sometimes cause the length of the run to be greater than shown. Therefore, install pull boxes in all telecommunications conduit runs so that the following conditions are met:

- a. Install pull boxes as required in conduit runs so that the distance between pull points is less than 100 feet.
- b. Install pull boxes in conduit runs so that a run of conduit does not contain more than the equivalent of two (2) ninety-degree bends (180 degrees total) between pull points.
- c. For reverse bends (between 100 and 180 degree), Insert a pull box at each bend.
- d. Pull boxes shall only be installed in straight sections of conduit, not in lieu of a bend.
- e. Each conduit entering and exiting a pull box shall be in direct alignment. (See Fig.#159 in 27 00 02 - APPENDIX B Labeling-Design-Syntax)
- f. Do not use "Condulet" type fittings in runs of telecommunications conduit.
- g. Pull boxes shall not be installed in restrooms, locker rooms or other similar facilities.
- h. Pull boxes larger than 18" square shall not be installed above hard ceilings.
- i. Pull boxes less than 18" square can be installed above hard ceilings provided an appropriately sized access hatch is installed.
- j. Pull boxes shall not be located in floors.
- k. Pull boxes shall include screws for each cutout in the cover plate
- l. Pull boxes larger than 24" in any dimension shall have a hinged lid(s).
- m. When a Structured Cable System cable bundle enters a pull box from a conduit, the same bundle shall exit the box in a single conduit without splitting off any cables from or adding any cables to, the bundle. NO DAISY-CHAINING OF PULL BOXES SHALL BE ALLOWED. (See Fig. #159 in 27 00 02 -APPENDIX B Labeling-Design-Syntax)

H. Pull Box Sizing

1. Pull Box serving a Single Faceplate

- a. For a pull box serving a single faceplate, a 4 11/16" box, 2 1/4" deep box is required.
2. Pull Box serving Horizontal Cabling
 - a. For a pull box serving a single conduit the length shall be 8 times the diameter of the conduit, width shall be 4 times the diameter and the depth shall be 2.5 times the diameter of the conduit. For each additional conduit of the same size, increase the width of the pull box by 2.5 times the diameter of the conduit.
 - b. For a single 1 1/4" conduit, minimum pull box size shall be 10" x 6" x 3" (LxWxD)
 - c. For two 1 1/4" conduits, minimum pull box size shall be 10" x 9" x 3"
3. Pull Box serving Backbone Cabling
 - a. For a pull box serving a single conduit the length shall be 10 times the diameter of the conduit, width shall be 4 times the diameter of the conduit and the depth shall be 2.5 times the diameter of the conduit. For each additional conduit of the same size, increase the width of the pull box by 2.5 times the diameter of the conduit.
 - b. For a single 2" conduit, minimum pull box size shall be 20" x 8" x 5"
 - c. For a single 4" conduit, minimum pull box size shall be 40" x 16" x 12"
 - d. For two 4" conduits, minimum pull box size shall be 40" x 26" x 12"
- I. Appropriate Application of Conduit
 1. Refer to Division 26 conduit applications unless where specifically identified in the Division 27.
 2. Rigid Metal Conduit or Intermediate Metal Conduit:
 - a. Where potentially exposed to physical damage.
 - b. Indoors where exposed to damp or moist environments such as crawlspaces.
 - c. Where outside plant cable enters the building to the point where it terminates.
 - d. Exposed installations within 10 feet above finished grade.
 - e. Where required by code, particularly Section 800-40 of the NEC
 3. Electrical Metallic Tubing:
 - a. General purpose distribution of telecommunications cabling, except where another conduit type is specifically required.

4. Rigid Non-Metallic Conduit:
 - a. Embedded in floor slabs.
- J. Appropriate Application of Back Boxes and Pull Boxes
 1. Cast Type Boxes:
 - a. Where connected to rigid metal conduit or intermediate metal conduit, 1¼" and smaller.
 - b. Exposed conduit installations within 10 feet above finished floor.
 - c. Where exposed to moisture and outdoors.
 2. Galvanized Pressed Steel Type Boxes:
 - a. Where connected to electrical metallic tubing, 1¼" and smaller.
 - b. Dry locations.
 - c. Where concealed in walls and above suspended ceilings.
 - d. The size for the typical back-box for wall mounted telecommunications faceplates shall be 4-11/16" square by 2-¼" deep with a single gang plaster ring, UON.
 3. Sheet Steel Boxes:
 - a. Where connected to conduit for use as a pull box.
 - b. Where used as a termination point for future cabling.
 - c. Where readily accessible.
- K. Innerduct
 1. All conduits where fiber optic cables are installed, with the exception of station fiber, are to use innerduct.
 2. Plastic Innerduct
 - a. Use plastic innerduct for any situations where a fiber optic cable is exposed within a building. Examples are to include transit from a cable tray or ladder racking.
 - b. Follow all manufacturers' written instructions, specifically as regarding use of a swivel.
 - c. Refer to drawings and conduit schedules for conduits designated to be used for fiber optic cables.
 - d. Each plastic innerduct is to carry a maximum of one fiber optic cable.

- e. Use terminal adapters to connect to fiber distribution cabinets, and other endpoints.
- f. Any break in continuous innerduct shall be joined using a coupler.
- g. Follow all manufacturers' written instructions and use plenum rated product where appropriate.

3.4 GROUNDING AND BONDING

- A. All metallic conduits are to be continuously bonded back to the PBB in the MDF, IDF or SDF.
- B. Refer to Section 27 05 26 for additional details.

3.5 TESTING

- A. For all conduits placed in the slab, use ball mandrel (diameter approximately 85% of conduit inside diameter) followed by close fitting wire brush and wad of felt or similar material to insure no blockages. This assembly shall be pulled with or ahead of cable being installed. Clean empty raceways similarly. Clear or replace any raceway which rejects ball mandrel.
- B. Testing must be done in the presence of the Cal Poly Designated Telecommunications Representative.

3.6 ACCEPTANCE

- A. Once the testing has been completed and the Cal Poly Designated Telecommunications Representative is satisfied that all work is in accordance with the Contract Documents, the representative will notify the Contractor and/or the Cal Poly Facilities Project Manager in writing or via email.

3.7 RECORD (AS-BUILT) DRAWINGS

- A. The Project Record Drawings shall show the types and locations of all conduits 2" and larger, and their associated pull boxes.

END OF SECTION

SECTION 27 05 37 – FIRESTOPPING SYSTEMS FOR COMMUNICATIONS CABLING

PART 1 - GENERAL

1.1 DESCRIPTION

- A. The work covered by this section of the Specifications includes all labor necessary to perform and complete such construction, all materials and equipment incorporated or to be incorporated in such construction and all services, facilities, tools and equipment necessary or used to perform a complete installation of the Telecommunications Systems and Components. The work of this section shall include, but is not limited to, the following:
- B. Firestop systems and installation as it relates to communications cabling.

1.2 QUALITY ASSURANCE

- A. Refer to Section 27 00 00 for general details.
- B. Provide Firestop systems that comply with the following requirements:
 - 1. Firestop material shall be tested by a qualified testing and inspection agency (UL or comparable).
 - 2. Only Firestop products bearing the classification marking of qualified testing and inspection agency shall be used.
- C. Installation personnel shall be by qualified and trained. Acceptable Installer qualifications are as follows:
 - 1. FM Research approved in accordance with FM AS 4991.
 - 2. Individuals or staff who are certified, licensed, or otherwise qualified by the Firestop manufacturer as having the necessary training and experience.
 - 3. Minimum of 1 year experience in the installation of manufacturer's products is required.
 - 4. The Installers shall have been trained by a direct representative of the manufacturer (not distributor or agent) in the proper selection and installation procedures.

1.3 CODES, STANDARDS, AND GUIDELINES

- A. Except as modified by governing codes and by the Contract Documents, comply

with the applicable provisions and recommendations in Section 27 00 00.

- B. ASTM E 84, "Surface Burning Characteristics of Building Materials".
- C. ASTM E 119, "Fire Tests of Building Construction and Materials".
- D. ASTM E 814, "Fire Tests of Penetration Firestop Systems".
- E. ANSI/UL263, "Fire Tests of Building Construction and Materials".
- F. ANSI/UL723, "Surface Burning Characteristics of Building Materials".
- G. ANSI/UL1479, "Fire Tests of Through Penetration Firestop".
- H. Underwriters Laboratories Inc. (UL) - Fire Resistance Directory
- I. The University Telecommunication Infrastructure Planning (UTIP) Standards document and section 27 00 02 - APPENDIX B Labeling-Design-Syntax.

1.4 SUBMITTALS

- A. Refer to Section 27 00 00 for general details.
- B. Shop Drawings:
 - 1. Indicate location of every communications firestop system, as well as which UL applications test applies.
- C. Submit Manufacturer's Cut Sheets for the following:
 - 1. Any products not specifically listed in the PRODUCTS section shall require a submittal of the manufacturer's cut sheets and approval by the Cal Poly Designated Telecommunications Representative.
 - 2. Any nonstandard penetration shall have a manufacturer approved fire rated assembly for non-standard fire-rated wall.

1.5 IDENTIFICATION

- A. At all installed locations, install a label on each side of the wall indicating the following information:
 - 1. Manufacturer of Firestop
 - 2. Name of product and UL System Number
 - 3. Name of installing contractor and date of installation.
 - 4. Rating of the wall/system.
 - 5. Install labels prior to the Design Engineer's above-ceiling inspection.
- B. Refer to Section 27 05 53 for additional details.

1.6 DEFINITIONS

- A. Communications cabling: Cabling to include telecommunications, data, coaxial, distributed antenna systems.
- B. Conduit sleeve: A conduit that only penetrates a single wall for the purpose of providing a pathway for communications cabling into adjacent rooms.
- C. Firestop Assembly: A manufactured product from a reputable company that is delivered to the contractor fully- or partially-assembled and when installed is rated as meeting the UL 1479 or ASTM E814 standards for fire testing and becomes part of a Firestop System for that particular type of installation.
- D. Firestop System: A product or series of products from a reputable manufacturing company that when installed properly by the contractor meets the UL 1479 or ASTM E814 standards for fire testing for that particular type of installation.
- E. Zero maintenance firestop assembly: A firestop assembly with a self-contained sealing system which shall automatically adjust to the installed cable loading and shall permit

cables to be installed, removed, or retrofitted without the need to adjust, remove or reinstall firestop material.

1.7 WARRANTY

- A. Refer to Section 27 00 00 for general

details. PART 2 - PRODUCTS

2.1 PRODUCT CONSISTENCY

- A. Any given item of equipment or material shall be the product of one manufacturer throughout the facility. Multiple manufacturers of any one item will not be permitted.

2.2 APPROVED MANUFACTURERS AND MATERIAL

- A. See Section 27 06 00 – Schedules for Communications for approved manufacturers and material to be supplied for this section.

2.3 ZERO-MAINTENANCE FIRESTOP ASSEMBLY

- A. Shall meet or exceed the ratings of the wall or floor that it penetrates.
- B. Shall be used for communications cabling at all interior wall penetrations through a single, fire-rated wall or floor.
- C. Shall be a listed (UL and/or FM) Firestop assembly system tested to UL 1479 or ASTM E814. The assembly size and quantity shall be determined as follows:

1. For round openings, fill ratio of cabling-to-opening-size shall not exceed 40%, or as dictated by the manufacturer, whichever is more stringent.
2. For rectangular openings, fill ratio of cabling-to-opening size shall not exceed 50%, or as dictated by the manufacturer, whichever is more stringent.
3. Include in cabling cross-sectional area enough spare capacity to accommodate 25% growth while maintaining the fill percentages in #1 and #2 above. Upon commissioning, if adequate spare capacity is not observed, contractor shall install additional assemblies at their own cost to provide such spare capacity.

2.4 FIRESTOPPING FOR COMMUNICATIONS CONDUITS & OTHER APPLICATIONS

- A. Required for all fire-rated wall penetrations where a communications pathway extends beyond a single fire- rated partition.
- B. Required for all telecommunications outlets located in fire-rated walls. System shall be UL CLIV tested.
- C. Shall be a listed (UL and/or FM) Firestop assembly system tested to UL 1479 or ASTM E814.
- D. Shall be re-enterable.
- E. Shall meet or exceed the ratings of the wall or floor that it

penetrates. PART 3- EXECUTION

3.1 GENERAL

- A. All firewall penetrations shall be sleeved and Firestop applied. (See Fig. #138 in 27 00 02 - APPENDIX B Labeling-Design-Syntax)
- B. All conduits (empty, partly filled or full) terminating in a telecommunications space shall have Firestop applied using plug style Firestop muffins.
- C. Communications cable tray may be continued through a fire-rated wall providing that approval from the AHJ is granted. Otherwise, stop the tray, install multiple zero- maintenance firestop assemblies, and continue tray on the other side. Ensure grounding of the cable tray is continuous through the wall.
- D. Provide Firestop assemblies of a sufficient size to accommodate the capacity of the cable tray (including the 25% allowance for growth in 40% max fill pathway).

3.2 QUANTITIES

- A. Quantities of Firestop elements shown on the drawings are illustrative only and are meant to indicate the general configuration of the work. The Contractor is responsible for providing the correct quantities of materials to construct a system that meets the intent of these Specifications and the relevant codes.

3.3 INSTALLATION

- A. Schedule installation of Firestop for after completion of penetrating item installation, but prior to covering or concealing of openings.
- B. Before beginning installation:
 - 1. Examine effected surfaces, as they shall be free of dirt, grease, oil, scale, laitance, rust, release agents, water repellants, and any other substances that may inhibit optimum adhesion.
 - 2. Provide masking and temporary covering to protect adjacent surfaces.
 - 3. Do not proceed until unsatisfactory conditions have been corrected.
- C. Do not install Firestop products when ambient or substrate temperatures are outside limitations recommended by manufacturer.
- D. Do not install Firestop products when substrates are wet due to rain, frost, condensation, or other causes.
- E. Maintain minimum temperature before, during, and for a minimum 3 days after installation of materials.
- F. Do not use materials that contain flammable solvents.
- G. Coordinate construction of openings and penetrating items to ensure that through penetration firestop systems are installed according to specified requirements.
- H. Coordinate sizing of sleeves, openings, core-drilled holes, or cut openings to accommodate through-penetration firestop systems.
- I. Install through-penetration firestop systems in accordance with the conditions of testing and classification as specified in the published design. Comply with manufacturer's instructions for installation of Firestop products.
- J. After installation:
 - 1. Remove equipment, materials, and debris, leaving area in undamaged, clean condition.

2. Clean all surfaces adjacent to sealed openings to be free of excess Firestop materials and soiling as work progresses.

3.4 GROUNDING AND BONDING

- A. Ensure grounding of the any metal pathways is continuous through any Firestop.
- B. Refer to Section 27 05 26 for additional details.

3.5 TESTING

- A. Verify requirements with Authority Having Jurisdiction and State Fire Marshall.

3.6 ACCEPTANCE

- A. Once the testing has been completed and the Cal Poly Designated Telecommunications Representative is satisfied that all work is in accordance with the Contract Documents, the representative will notify the Contractor and/or the Cal Poly Facilities Project Manager in writing or via email.

3.7 RECORD (AS-BUILT) DRAWINGS

- A. On shop drawings and record drawings, indicate location of every communications Firestop system, as well as which UL applications test applies.

END OF SECTION

SECTION 27 05 39 – SURFACE RACEWAYS FOR COMMUNICATIONS SYSTEMS

PART 1 - GENERAL

1.1 DESCRIPTION

- A. The work covered by this section of the Specifications includes all labor necessary to perform and complete such construction, all materials and equipment incorporated or to be incorporated in such construction and all services, facilities, tools and equipment necessary or used to perform a complete installation of the Telecommunications Systems and Components. The work of this section shall include, but is not limited to, the following:
 - 1. Surface Raceways and accessories
- B. Surface Raceways shall only to be used in facility remodels if deemed necessary and shall not to be used for new building/residential construction without the specific approval of the Cal Poly Designated Telecommunications Representative. Surface Raceway may be specified for use in certain computer labs or office areas if the need is justified and the specific use is preapproved by the Cal Poly Designated Telecommunications Representative.

1.2 QUALITY ASSURANCE

- A. Refer to Section 27 00 00 for general details.

1.3 CODES, STANDARDS, AND GUIDELINES

- A. Except as modified by governing codes and by the Contract Documents, comply with the applicable provisions and recommendations in Section 27 00 00.
- B. UL 5 - Surface Metal Raceways and Fittings.
- C. UL 514A - Metallic Outlet Boxes.
- D. UL 514C - Nonmetallic Outlet Boxes, Flush-Device Boxes, and Covers.
- E. The University Telecommunication Infrastructure Planning (UTIP) Standards document and section 27 00 02 - APPENDIX B Labeling-Design-Syntax.

1.4 SUBMITTALS

- A. Refer to Section 27 00 00 for general details.
- B. Shop Drawings:

1. Coordinated conduit layout drawings, 1/8 inch scale, minimum. Show routing of all surface raceways.

C. Submit Manufacturer's Cut Sheets for the following:

1. Any products not specifically listed in the PRODUCTS section shall require a submittal of the manufacturer's cut sheets and approval by the Cal Poly Designated Telecommunications Representative.

1.5 IDENTIFICATION

- A. In accordance with section 27 00 02 - APPENDIX B Labeling-Design-Syntax.

1.6 DEFINITIONS

- A. N/A

1.7 WARRANTY

- A. Refer to Section 27 00 00 for general

details. PART 2 - PRODUCTS

2.1 PRODUCT CONSISTENCY

- A. Any given item of equipment or material shall be the product of one manufacturer throughout the facility. Multiple manufacturers of any one item will not be permitted.

2.2 APPROVED MANUFACTURERS AND MATERIAL

- A. See Section 27 06 00 – Schedules for Communications for approved manufacturers and material to be supplied for this section.

2.3 SURFACE RACEWAY

- A. Size according to Execution section.
B. See Fig. #158 in 27 00 02 - APPENDIX B Labeling-Design-

Syntax. PART 3- EXECUTION

3.1 GENERAL

- A. Use metal raceway.
B. All transitions in either the horizontal or vertical plane shall be fiber rated radiused fittings.
C. Transitions shall have the same carrying capacity as the elements they connect.
D. Prepare surfaces using the methods recommended by the manufacturer for achieving the best result for the substrate under the project conditions.

- E. Install all components necessary to make a complete, code-compliant, specification-compliant installation.
- F. All components used shall be employed in the manner intended by the manufacturer.
- G. Sections of surface raceway less than 7' in length shall be a single piece of raceway.
- H. Raceway Sizing (For undivided raceways): Using (Legrand/Wiremold Series for sizing)

# of Cat6 Cables	# of Cat6A	Surface Conduit
2	1	v2000 or
7	3	v2000 or
58	29	4000 or equal
33	16	5500 or equal

3.2 QUANTITIES

- A. Quantities of raceway elements shown on the drawings are illustrative only and are meant to indicate the general configuration of the work. The Contractor shall be responsible for providing the correct quantities of materials to construct a system that meets the intent of these Specifications and all relevant codes.

3.3 INSTALLATION

- A. Follow all manufacturers' written instructions.
- B. Wall-mounted raceway shall be installed with adequate volume behind the jacks to allow required bend radii as well as sufficient cable pathway.

3.4 GROUNDING AND BONDING

- A. All metal surface raceways shall be properly bonded and grounded.
- B. Refer to Section 27 05 26 for additional details.

3.5 TESTING

- A. None Required

3.6 ACCEPTANCE

- A. Once the installation has been completed and the Cal Poly Designated Telecommunications Representative is satisfied that all work is in accordance with the Contract Documents, the representative will notify the Contractor and/or the Cal Poly Facilities Project Manager in writing or via email.

3.7 RECORD (AS-BUILT) DRAWINGS

- A. Show type and indicate all surface mounted conduit on project

Drawings. END OF SECTION

SECTION 27 05 43 – UNDERGROUND DUCTS AND RACEWAYS FOR COMM SYSTEMS

PART 1 - GENERAL

1.1 DESCRIPTION

A. The work covered by this section of the Specifications includes all labor necessary to perform and complete such construction, all materials and equipment incorporated or to be incorporated in such construction and all services, facilities, tools and equipment necessary or used to perform a complete installation of the Telecommunications Systems and Components. The work of this section shall include, but is not limited to, the following:

1. Conduits, Ducts, and Duct Banks
2. (Signal) Hand Holes (SPH)
3. (Signal) Pull Boxes (SPB)
4. (Signal) Vaults/Maintenance Holes (SMH)

1.2 QUALITY ASSURANCE

A. Refer to Section 27 00 00 for general details.

1.3 CODES, STANDARDS, AND GUIDELINES

- A. Except as modified by governing codes and by the Contract Documents, comply with the applicable provisions and recommendations in Section 27 00 00.
- B. AASHTO HB 17 - American Association of State Highway and Transportation Officials, Standard Specifications for Highway Bridges, 17th Edition
- C. ANSI C80.1 - Galvanized Rigid Steel Conduit
- D. ANSI C1037 - Standard Practice for Inspection of Underground Precast Concrete Utility Structures
- E. ASTM A48/A48M - Standard Specification for Grey Iron Castings
- F. ASTM F512 - Standard Specification for Smooth-Wall PVC Conduit and Fittings for Underground Installation
- G. ASTM C857-95 - Standard Practice for Minimum Structural Design Loading for Underground Precast Concrete Utility Structures

- H. ASTM C858 - Standard Specification for Underground Precast Concrete Utility Structures
- I. ASTM C891 - Standard Practice for Installation of Underground Precast Concrete Utility Structures
- J. ASTM C 1037 - Standard Practice for Inspection of Underground Precast Concrete Utility Structures
- K. Cal PUC G.O. 128 Rules for Construction of Underground Electrical Supply and Communications Systems, State of California Public Utilities Commission
- L. ISO 9000 - Quality Management Systems - Fundamentals and Vocabulary
- M. ISO 10012 - Measurement Management Systems, Requirements for Measurement Processes and Measuring Equipment
- N. NEMA TC2 - Electrical PVC Conduit
- O. NEMA TC3 - PVC Fittings for Use with Rigid PVC Conduit and Tubing
- P. NEMA TC6&8 - PVC Plastic Utilities Duct for Underground Installations
- Q. NEMA TC9 - Fittings for PVC Plastic Utilities Duct for Underground Installations
- R. SCTE 77 - Specification for Underground Enclosure Integrity, Society of Cable Telecommunications Engineers
- S. UL 651 - Schedule 40 and 80 Rigid PVC Conduit and Fittings
- T. UL 514B - Conduit, Tubing, and Cable Fittings
- U. The University Telecommunication Infrastructure Planning (UTIP) Standards document and section 27 00 02 - APPENDIX B Labeling-Design-Syntax.

1.4 SUBMITTALS

- A. Refer to Section 27 00 00 for general details.
- B. Shop Drawings:
 - 1. Shop drawings shall show the position of all underground telecommunications Vaults, Pull Boxes, Hand Holes, Ducts, Duct Banks and Conduits.
 - 2. Drawings are to indicate as-built fill percentages on all conduits within the project scope.
- C. Submit Manufacturer's Cut Sheets for the following:
 - 1. Any products not specifically listed in the PRODUCTS section shall require a

submission of the manufacturer's cut sheets and approval by the Cal Poly Designated Telecommunications Representative.

1.5 IDENTIFICATION

- A. Refer to Section 27 05 53 for general details.
- B. All Vault Covers, Pull Box and Hand Hole lids are to be factory labeled (at minimum) "COMMUNICATIONS". (See Fig. #156 & 157 in 27 00 02 - APPENDIX B Labeling- Design-Syntax)
- C. All copper and fiber cables run underground shall be labeled in each Vault, Pull Box, Hand Hole, and Pull Box with the appropriate label as detailed in Section 27 05 53, and described in Section 27 00 02 - APPENDIX B Labeling-Design-Syntax.

1.6 DEFINITIONS

- A. Duct: Interchangeable term for a conduit.
- B. Duct Bank: An assembly of conduits that may either be directly buried in earth or encased in concrete.
- C. Signal Hand Hole (SHH): Small underground structure (15" x 20" x 10") containing a maximum of one 2" conduit and is typically used for distribution to a single end point.
- D. Signal Pull Box (SPB): Small underground structure (15" x 26 x 18") containing a maximum of two 4" conduits.
- E. Signal Manhole (SMH): Large underground structure of varying size used for 4" conduits.
 - 1. Up to six 4" conduits minimum vault size is 5' x 7' x 7'
 - 2. Six to twelve 4" conduits minimum vault size is 6' x 10' x 7'
 - 3. Thirteen to eighteen 4" conduits minimum vault size is 6' x 12' x 7'
 - 4. Nineteen to twenty four 4" conduits minimum vault size is 8' x 15' x 7'

1.7 WARRANTY

- A. Refer to Section 27 00 00 for general

details. PART 2 - PRODUCTS

2.1 PRODUCT CONSISTENCY

- A. Any given item of equipment or material shall be the product of one manufacturer throughout the facility. Multiple manufacturers of any one item will not be permitted, unless specifically noted otherwise.

2.2 APPROVED MANUFACTURERS AND MATERIAL

- A. See Section 27 06 00 – Schedules for Communications for approved manufacturers and material to be supplied for this section.

2.3 METALLIC CONDUIT

- A. Rigid Steel Conduit: Galvanized. Comply with ANSI C80.1.
- B. RNC: NEMA TC 2, Type EPC-40-PVC, UL 651, with matching fittings by same manufacturer as the conduit, complies with NEMA TC 3 and UL 514B.

2.4 NONMETALLIC DUCTS AND DUCT ACCESSORIES

- A. Underground Plastic Utilities Duct: NEMA TC 6 & 8, Type DB-40-PVC, ASTM F 512, with matching fittings by the same manufacturer as the duct, complying with NEMA TC 9.
- B. Duct Accessories:
 - 1. Duct Separators: Factory-fabricated rigid PVC interlocking spacers, sized for type and sizes of ducts with which used, and selected to provide the minimum duct spacing indicated while supporting ducts during concreting or backfilling.
 - 2. Warning Tape:
 - a. Tape is to be metal/detectable
 - b. Color: Orange
 - c. Labeled "FIBER OPTIC CABLE" or "COMMUNICATIONS"

2.5 PRECAST CONCRETE SIGNAL PULL HOLE (SPH)

- A. Comply with ASTM C 858 for design and manufacturing processes.
- B. Factory-fabricated, reinforced-concrete, monolithically poured walls and bottom unless open-bottom enclosures are indicated. Frame and cover shall form top of enclosure and shall have load rating consistent with that of the hand hole.
- C. Cover Legend: Molded lettering, "COMMUNICATIONS" (at minimum)
- D. Configuration: Units shall be designed for flush burial and have open bottom, unless otherwise indicated.

2.6 PRECAST CONCRETE SIGNAL PULL BOX (SPB)

- A. Comply with ASTM C 858 for design and manufacturing processes.
- B. Factory-fabricated, reinforced-concrete, monolithically poured walls and

- bottom. Frame and cover shall form top of enclosure and shall have load rating consistent with that of the pull box.
- C. Frame and Cover: Weatherproof cast-iron frame, with cast-iron cover with recessed cover hook eyes and tamper-resistant, captive, cover-securing bolts.
 - D. Cover Finish: Nonskid finish shall have a minimum coefficient of friction of 0.50.
 - E. Cover Legend: Molded lettering, "COMMUNICATIONS" (at minimum) (See Fig. #156 & 157 in Section 27 00 02 - APPENDIX B Labeling-Design-Syntax)
 - F. Configuration: Units shall be designed for flush burial.
 - G. Extensions and Slabs: Designed to mate with bottom of enclosure. Use same material as enclosure.
 - 1. Extension shall provide increased depth of 12 inches.
 - 2. Slab: Same dimensions as bottom of enclosure and arranged to provide closure.
 - H. Windows: Precast openings in walls, arranged to match dimensions and elevations of approaching ducts and duct banks plus an additional 12 inches vertically and horizontally to accommodate alignment variations.
 - 1. Windows shall be located no less than 6 inches from interior surfaces of walls, floors, or frames and covers of pull boxes, but close enough to corners to facilitate racking of cables on walls.
 - 2. Window opening shall have cast-in-place, welded wire fabric reinforcement for field cutting and bending to tie into concrete envelopes of duct banks.
 - 3. Window openings shall be framed with at least two additional No. 4 steel reinforcing bars in concrete around each opening.
 - I. Duct Entrances in Pull Box Walls: Cast end-bell or duct-terminating fitting in wall for each entering duct.
 - 1. Type and size shall match fittings to duct or conduit to be terminated.
 - 2. Fittings shall align with elevations of approaching ducts and be located near interior corners of pull boxes to facilitate racking of cable.
 - 3. All ducts entering pull boxes shall be grouted in place flush with the finished surface.
 - J. Pull Boxes 12 inches wide by 24 inches long and larger shall have inserts for cable racks and pulling-in irons installed before concrete is poured.

2.7 PRECAST SIGNAL MANHOLE (SMH)

- A. Comply with ASTM C 858, with structural design loading as specified in Part 3 "Underground Enclosure Application" Article and with interlocking mating sections, complete with accessories, hardware, and features.
- B. Windows: Precast openings in walls, arranged to match dimensions and elevations of approaching ducts and duct banks plus an additional 12 inches vertically and horizontally to accommodate alignment.
 - 1. Windows shall be located no less than 6 inches from interior surfaces of walls, floors, or roofs of vaults, but close enough to corners to facilitate racking of cables on walls.
 - 2. Window opening shall have cast-in-place, welded wire fabric reinforcement for field cutting and bending to tie into concrete envelopes of duct banks.
 - 3. Window openings shall be framed with at least two additional No. 4 steel reinforcing bars in concrete around each opening.
 - 4. Duct Entrances in Vault Walls: Cast end-bell or duct-terminating fitting in wall for each entering duct.
 - a. Type and size shall match fittings to duct or conduit to be terminated.
 - b. Fittings shall align with elevations of approaching ducts and be located near interior corners of vaults to facilitate racking of cable.
 - c. All ducts entering vaults shall be grouted in place flush with the finished surface.
- C. Concrete Knockout Panels: 1-1/2 to 2 inches thick, for future conduit entrance and sleeve for ground rod.
- D. Joint Sealant: Asphaltic-butyl material with adhesion, cohesion, flexibility, and durability properties necessary to withstand maximum hydrostatic pressures at the installation location with the ground-water level at grade.

2.8 UTILITY STRUCTURE ACCESSORIES

- A. Vault Frames, Covers, and Chimney Components: Comply with structural design loading specified for vault.
 - 1. Frame and Cover: Weatherproof, gray cast iron complying with ASTM A 48/A 48M, Class 30B with milled cover-to-frame bearing surfaces; diameter, 26 inches.
 - a. Cover Finish: Nonskid finish shall have a minimum coefficient of friction of 0.50.

- b. Special Covers: Recess in face of cover designed to accept finish material in paved areas.
- 2. Cover Legend: Cast in.
 - a. Legend: "COMMUNICATIONS" (at minimum), for Telecommunications, data, and telephone duct systems. (See Fig. #156 & 157 in Section 27 00 02 - APPENDIX B Labeling-Design-Syntax)
- B. Vault Sump Frame and Grate: ASTM A 48/A 48M, Class 30B, gray cast iron.
- C. Pulling Eyes in Concrete Walls: Eyebolt with reinforcing-bar fastening insert, 2-inch- diameter eye, and 1-by-4-inch bolt.
 - 1. Working Load Embedded in 6-Inch, 4000-psi Concrete: 13,000-lbf minimum tension.
- D. Pulling Eyes in Nonconcrete Walls: Eyebolt with reinforced fastening, 1-1/4-inch- diameter eye, rated 2500- lbf. minimum tension.
- E. Pulling-In and Lifting Irons in Concrete Floors: 7/8-inch- diameter, hot-dip galvanized, bent steel rod; stress relieved after forming; and fastened to reinforcing rod. Exposed triangular opening.
 - 1. Ultimate Yield Strength: 40,000-lbf shear and 60,000-lbf tension.
- F. Bolting Inserts for Concrete Utility Structure Cable Racks and Other Attachments: Flared, threaded inserts of noncorrosive, chemical-resistant, nonconductive thermoplastic material; 1/2-inch ID by 2-3/4 inches deep, flared to 1-1/4 inches minimum at base.
 - 1. Tested Ultimate Pullout Strength: 12,000-lbf minimums.
- G. Expansion Anchors for Installation after Concrete Is Cast: Zinc-plated, carbon-steel- wedge type with stainless-steel expander clip with 1/2-inch bolt, 5300-lbf rated pullout strength, and minimum 6800-lbf rated shear strength.
- H. Cable Rack Assembly: Steel, hot-dip galvanized, except insulators.
 - 1. Stanchions: T-section or channel; 2-1/4-inch nominal size; punched with 14 holes on 1-1/2-inch centers for cable-arm attachment.
 - 2. Arms: 1-1/2 inches wide, lengths ranging from 3 inches with 450-lb minimum capacity to 18 inches with 250-lb minimum capacity. Arms shall have slots along full length for cable ties and be arranged for secure mounting in horizontal position at any vertical location on stanchions. Provide two arms per stanchion section.
 - 3. Insulators: High-glaze, wet-process porcelain arranged for mounting on cable

arms.

- I. Duct-Sealing Compound: Non-hardening, safe for contact with human skin, not deleterious to cable insulation, and workable at temperatures as low as 35° F. Capable of withstanding temperature of 300° F without slump and adhering to clean surfaces of plastic ducts, metallic conduits, conduit coatings, concrete, masonry, lead, cable sheaths, cable jackets, insulation materials, and common metals. (See Fig. #136 in Section 27 00 02 - APPENDIX B Labeling-Design-Syntax)
- J. Fixed Vault Ladders: Arranged for attachment to wall of vault. Ladder and mounting brackets and braces shall be fabricated from hot-dip galvanized steel.
- K. Cover Hooks: Heavy duty, designed for lifts 60 lbs. and greater. Two required.

2.9 UNDERGROUND ENCLOSURE APPLICATION

- A. (Signal) Hand Holes (SPH) and (Signal) Pull Boxes (SPB)
 - 1. Units in Roadways and Other Deliberate Traffic Paths:
 - a. Precast concrete. AASHTO HB 17, H-10 structural load rating.
 - 2. Units in Driveway, Parking Lot, and Off-Roadway Locations, Subject to Occasional, Non-deliberate Loading by Heavy Vehicles:
 - a. Precast concrete, AASHTO HB 17, H-20 structural load rating.
 - 3. Units in Sidewalk and Similar Applications with a Safety Factor for Non-deliberate Loading by Vehicles:
 - a. Precast concrete, AASHTO HB 17, H-10 structural load rating.
- B. Vaults: Precast or cast-in-place concrete.
 - 1. Units Located in Roadways and Other Deliberate Traffic Paths by Heavy or Medium Vehicles:
 - a. AASHTO HB 17, H-20 structural load rating.
 - 2. Units Not Located in Deliberate Traffic Paths by Heavy or Medium Vehicles:
 - a. AASHTO HB 17, H-10 structural load rating.

2.10 DUCT SEAL (POPULATED WITH CABLING)

- A. To be used only in situations where a fire rated assembly is not required.
- B. Shall be Asbestos Free, easily formable clay.
- C. Shall not dry hard but shall be re-enterable/reusable.
- D. Shall be Resistant to water, alcohols, solvents & fuels.

- E. Shall be non-corrosive to metals or plastics and a non-irritant to skin.

2.11 DUCT SEAL (UNPOPULATED CONDUITS)

- A. To be used only in situations where a fire rated assembly is not required.
- B. Shall be removable and reusable compression type fittings. (See Fig. #137 in Section 27 00 02 - APPENDIX B Labeling-Design-Syntax)
- C. Shall be corrosion proof, water-tight and gas-tight.
- D. Shall be equipped with a rear side pull rope

tiedown. PART 3- EXECUTION

3.1 GENERAL

- A. Cut trenches neatly and uniformly, and slope uniformly away from underground structures and building entrances.
- B. Restore surface features at areas disturbed by excavation and reestablish original grades except as otherwise indicated. Restore all areas disturbed by trenching, storing of dirt, cable laying, and other work. Replace removed sod immediately after backfilling is completed.

3.2 QUANTITIES

- A. Quantities of system elements shown on the drawings are illustrative only and shall be meant to indicate the general configuration of the work. The Contractor shall be responsible for providing the correct quantities of materials to construct a system that meets the intent of these Specifications and all relevant codes.

3.3 INSTALLATION

- A. Conduit and Duct Installation
 1. Install nonmetallic conduit and duct as indicated according to manufacturer's written instructions.
 2. Pitch ducts minimum of 4 inches per 100 feet (1:300) to drain away from building entrances.
 3. Use manufactured long sweep bends with a minimum radius of 48" both horizontally and vertically at all locations.
 4. Make joints in ducts and fittings watertight in accordance with manufacturer's instructions. Duct joint sealing should be avoided if ambient temperature is over 86° (F). Stagger couplings so those adjacent ducts do not lie in the same plane.

5. Space cast-in-place end bells approximately 8 inches on center in a pattern that best meets the requirements of the arrangement of the duct bank for 5-inch ducts and varied proportionately for other duct sizes. Change from regular spacing to end bell spacing, 10 ft. from the end bell without reducing duct line slope and without forming a trap in the line. Grout end bells into vault walls from both sides to provide watertight entrances.
6. Support concrete encased nonmetallic ducts on plastic separators coordinated with duct size and required duct spacing, and install according to the following:
 - a. Space separators 4-feet on centers to prevent sagging and deforming of ducts, and secure separators to the earth and to ducts to prevent floating during concreting.
 - b. Spade concrete carefully during pours to prevent voids under and between conduits and at exterior surface of envelope. Do not use power-driven agitating equipment unless specifically designed for duct bank application. Pour each run of envelope between vaults or other terminations in one continuous operation. When more than one pour is necessary, terminate each pour in a vertical plane and install 3/4-inch reinforcing rod dowels extending 18 inches into the concrete on both sides of joint near the corners of the envelope.
 - c. Use the walls of the trench to form the side walls of the duct bank where the soil is self-supporting and concrete envelope can be poured without soil inclusions, otherwise use forms.
 - d. Three inches minimum clearance between ducts and exterior envelope wall, 7.5 inches minimum clearance between ducts for like services and 12 inches minimum clearance between power and signal ducts.
 - e. Except as otherwise indicated on the Civil drawings, install top of duct bank at least 36 inches below finished grade.
7. Use galvanized rigid steel conduit for stub-ups to equipment. For equipment mounted on outdoor concrete pads, extend steel conduit a minimum of 5 feet from edge of pad. Install insulated grounding bushings on the terminations. Couple steel conduits to the ducts with adapters designed for the purpose and then encase coupling with 3 inches of concrete.
8. Provide temporary closure at terminations of ducts that are wired under this Project. Seal spare ducts at terminations. Use sealing compound and plugs

to withstand at least 15 psi hydrostatic pressure.

9. Install 600-pound test nylon rope as a pull rope in ducts, including spares.

B. Duct Installation

1. Use 5-degree angle couplings for small changes in direction. Use manufactured long sweep bends with a minimum radius of 48 inches, both horizontally and vertically, at other locations, unless otherwise indicated.
2. Use solvent-cemented joints in ducts and fittings and make watertight according to manufacturer's written instructions. Stagger couplings so those of adjacent ducts do not lie in same plane.
3. At duct entrances to vaults, pull boxes and hand holes, use end bells, spaced approximately 10 inches on center for 5-inch ducts, and vary proportionately for other duct sizes.
 - a. Begin change from regular spacing to end-bell spacing 10 feet from the end bell without reducing duct line slope and without forming a trap in the line.
 - b. Direct-Buried Duct Banks: Install an expansion and deflection fitting in each conduit in the area of disturbed earth adjacent to vaults, pull boxes and hand holes.
 - c. Grout end bells into structure walls from both sides to provide watertight entrances.
4. For building wall penetrations, make a transition from underground duct to rigid steel conduit at least 10 feet outside the building wall without reducing duct line slope away from the building, and without forming a trap in the line. Use fittings manufactured for duct-to-conduit transition.
5. Provide temporary closure at terminations of ducts that are wired under this Project. Seal spare ducts at terminations. Use sealing compound and plugs to withstand at least 15 psi hydrostatic pressure.
6. Concrete-Encased Ducts: Support ducts on duct separators.
 - a. Space separators close enough to prevent sagging and deforming of ducts, with not less than 4 spacers per 20 feet of duct. Secure separators to earth and to ducts to prevent floating during concreting. Stagger separators approximately 6 inches between tiers. Tie entire assembly together using fabric straps; do not use tie wires or reinforcing steel that may form conductive or magnetic loops around ducts or duct groups.

- b. Pour each run of envelope between vaults or other terminations in one continuous operation. Unless otherwise specified, the term "concrete", as it relates to the fill envelope encasing buried communications duct banks, shall mean a "2 bag" sand slurry mix.
 - 1) Start at one end and finish at the other, allowing for expansion and contraction of ducts as their temperature changes during and after the pour. Use expansion fittings installed according to manufacturer's written recommendations or use other specific measures to prevent expansion- contraction damage.
 - 2) If more than one pour is necessary, terminate each pour in a vertical plane and install 3/4-inch reinforcing rod dowels extending 36 inches into concrete on both sides of joint near corners of envelope.
- c. Spade concrete carefully during pours to prevent voids under and between conduits and at exterior surface of envelope. Do not allow a heavy mass of concrete to fall directly onto ducts. Use a plank to direct concrete down sides of bank assembly to trench bottom. Allow concrete to flow to center of bank and rise up in middle, uniformly filling all open spaces. Do not use power-driven agitating equipment unless specifically designed for duct-bank application.
- d. Reinforce concrete-encased duct banks where they cross disturbed earth and where indicated. Arrange reinforcing rods and ties without forming conductive or magnetic loops around ducts or duct groups.
- e. Use walls of trench to form side walls of duct bank where soil is self-supporting and concrete envelope can be poured without soil inclusions; otherwise, use forms.
- f. Provide 3 inches minimum space between ducts and exterior envelope wall, 2 inches minimum space between ducts for like services, and 4 inches minimum space between power and signal ducts.
- g. Install top of duct bank at least 36 inches below finished grade in areas not subject to deliberate traffic, and also at least 36 inches below finished grade in deliberate traffic paths for vehicles, unless greater depth is otherwise indicated on approved drawings.
- h. Use manufactured rigid steel conduit elbows for stub-ups at poles and equipment and at building entrances through the floor.

- 1) Couple steel conduits to ducts with adapters designed for this

- purpose and encase coupling with 3 inches of concrete.
- 2) Stub-Ups to Equipment: For equipment mounted on outdoor concrete bases, extend steel conduit horizontally a minimum of 60 inches from edge of base. Install insulated grounding bushings on terminations at equipment.
 - i. Bury warning tape approximately 12 inches above all concrete-encased ducts and duct banks. Align tape parallel to and within 3 inches of the centerline of duct bank. Provide an additional warning tape for each 12-inch increment of duct bank width over a nominal 18 inches. Space additional tapes 12 inches apart, horizontally.
7. Direct-Buried Duct Banks:
- a. Support ducts on duct separators coordinated with duct size, duct spacing, and outdoor temperature.
 - b. Space separators close enough to prevent sagging and deforming of ducts, with not less than 4 spacers per 20 feet of duct. Secure separators to earth and to ducts to prevent displacement during backfill and yet permit linear duct movement due to expansion and contraction as temperature changes. Stagger spacers approximately 6 inches between tiers.
 - c. Install ducts with a minimum of 3 inches between ducts for like services and 12 inches between power and signal ducts.
 - d. Install top of duct bank at least 36 inches below finished grade, unless otherwise indicated on approved drawings.
 - e. Set elevation of bottom of duct bank below the frost line.
 - f. Install manufactured rigid steel conduit elbows for stub-ups at poles and equipment and at building entrances through the floor.
 - 1) Couple steel conduits to ducts with adapters designed for this purpose and encase coupling with 3 inches of concrete.
 - 2) For equipment mounted on outdoor concrete bases, extend steel conduit horizontally a minimum of 60 inches from edge of equipment pad or foundation. Install insulated grounding bushings on terminations at equipment.
8. Duct Entrances to Buildings:
- a. For entrances using steel or schedule 80 PVC conduit, transformations

from underground duct to conduit shall be made 10 ft. minimum, outside the building wall and shall use fittings manufactured for the purpose. Install in accordance with the following:

- b. For entrances using Concrete-Encased Ducts, install reinforcing in duct banks through disturbed earth near buildings and excavations and coordinate duct bank with structural design at wall so duct bank is supported at wall without reducing structural or watertight integrity.
- c. For waterproof entrances: Where ducts enter buildings through a waterproofed floor or wall, a watertight entrance-sealing device shall be installed with the sealing gland assembly on the inside. The device shall be securely anchored into the masonry construction with one or more integral flanges and the membrane waterproofing secured to the device in a permanently watertight manner.

C. Underground Utility Structure Installation

1. Install vaults with roof top 24 inches below finished grade, typical. Covers shall be adjusted to finish grade and carefully grouted in to provide adequate bearing for H- 20 traffic loading.
2. Install removable hardware including cable stanchions, cable arms, and insulators as required for installation and support of cable and conductors. (See Fig. #165 in Appendix B)
3. Do not drill deeper than 3-7/8 inches for anchor bolts installed in the field.
4. Install precast concrete underground structures as indicated, according to manufacturer's written instructions and ASTM C 891.
 - a. Install units plumb and level and with orientation and depth coordinated with arrangement of connecting ducts to minimize bends and deflections required for proper entrances.
 - b. Support units on a 12-inch level bed of crushed stone or gravel, graded from the 1-inch sieve to the No. 4 sieve and compacted to same density as adjacent undisturbed earth.

D. Installation of Concrete Vaults, Pull Boxes, and Hand Holes

1. Precast Concrete Vault and Pull Box:
 - a. Comply with ASTM C 891, unless otherwise indicated.
 - b. Install units level and plumb and with orientation and depth coordinated with connecting ducts to minimize bends and deflections

required for proper entrances.

- c. Unless otherwise indicated, support units shall be placed on a 12" deep level bed of crushed stone or gravel, graded from 1-inch sieve to No. 4 sieve and compacted to same density as adjacent undisturbed earth.
2. Elevations:
 - a. Vault Roof: Install with rooftop at least 15 inches below finished grade.
 - b. Vault Frame: In paved areas and traffic-ways, set frames flush with finished grade.
 - c. Pull Box Covers: In paved areas and traffic-ways, set surface flush with finished grade.
 - d. Where indicated, cast pull box cover frame integrally with pull box structure.
 3. Install drains in bottom of vaults where indicated. Coordinate with drainage provisions indicated.
 4. Circular opening in Vault roof; sized to match cover size.
 - a. Vaults with Fixed Ladders: Offset access opening from vault centerlines to align with ladder.
 - b. Install chimney, constructed of precast concrete collars and rings to support frame and cover and to connect cover with vault roof opening. Provide moisture-tight masonry joints and waterproof grouting for cast-iron frame to chimney.
 - c. No more than a total of 24" of traffic rings are to be used.
 5. Apply waterproofing to exterior surfaces of vaults and pull boxes after concrete has cured at least three days. After ducts have been connected and grouted, and before backfilling, waterproof joints and connections and touch up abrasions and scars. Waterproof exterior of vault chimneys after mortar has cured at least three days.
 6. Install removable hardware, including pulling eyes, cable stanchions, and cable arms, and insulators, as required for installation and support of cables and conductors and as indicated.
 7. Install fixed vault ladders to provide for safe entry with maximum clearance from cables and other items in vaults.

E. CLEANING

1. Pull brush through full length of ducts. Use round bristle brush with a diameter 1/2 inch greater than internal diameter of duct.
2. Pull leather-washer-type duct cleaner, with graduated washer sizes, through full length of ducts. Follow with rubber duct swab for final cleaning and to assist in spreading lubricant throughout ducts.
3. Clean internal surfaces of vaults, including sump. Remove foreign material.

3.4 GROUNDING AND BONDING

- A. Install ground rod through floor of each vault with top protruding 4 inches above floor. Ground rod shall be installed during placement of the vault, in a corner of the vault. Ground rod is not to be placed in the center of the vault.
- B. Seal the floor opening against water penetration with waterproof non-shrink grout.
- C. Ground all exposed metal components and hardware with #2 bare copper ground conductor. Run conductors neatly around corners. Install on walls and roof using cable clamps secured with expansion anchors.
- D. A continuous #2 bare copper conductor shall extend with each conduit or duct bank entering and leaving the structure to the next underground structure or building. This conductor shall be bonded to the duct bank steel reinforcement bar (if used) every 20'.
- E. All ground connections for underground structures shall be installed using exothermic welding. Refer to Section 27 05 26 for additional details.

3.5 TESTING

- A. Test and inspect precast concrete utility structures according to ASTM C 1037.
 1. Strength tests of complete boxes and covers shall be by either an independent testing agency or the manufacturer. A qualified registered professional engineer shall certify tests by manufacturer.
 2. Testing machine pressure gages shall have current calibration certification complying with ISO 9000, ISO 10012 and traceable to NIST standards.
- B. Testing: demonstrate capability and compliance with requirements upon completion of installation of underground duct and utility structures.
 1. Test vault grounding to ensure electrical continuity of bonding and grounding connections. Measure ground resistance at each ground rod and report results. Use an instrument specifically designed for ground-resistance measurements.

2. Rod ducts with a mandrel 1/4 inch smaller in diameter than internal diameter of ducts. Where rodding indicates obstructions in ducts, remove the obstructions and retest.
 3. Test for water leaks.
- C. Correct installations where possible, and retest to demonstrate compliance. Otherwise, remove and replace defective products and retest.
 - D. All testing must be done in the presence of the Cal Poly Designated Telecommunications Representative.

3.6 ACCEPTANCE

- A. Once the installation and testing has been completed and the Cal Poly Designated Telecommunications Representative is satisfied that all work is in accordance with the Contract Documents, the representative will notify the Contractor and/or the Cal Poly Facilities Project Manager in writing or via email.

3.7 RECORD (AS-BUILT) DRAWINGS

- A. The Project Record Drawings shall show the position and depth of all underground telecommunications vaults, pull boxes, hand holes, ducts, duct banks and conduits.
- B. Drawings are also to indicate as-built fill percentages on all conduits within the project scope.

END OF SECTION

SECTION 27 05 53 – IDENTIFICATION FOR COMMUNICATIONS SYSTEMS

PART 1 - GENERAL

1.1 DESCRIPTION

- A. The work covered by this section of the Specifications includes all labor necessary to perform and complete such construction, all materials and equipment incorporated or to be incorporated in such construction and all services, facilities, tools, and equipment necessary or used to perform a complete installation of the Telecommunications Systems and Components. The work of this section shall include, but is not limited to, the following:

- 1. Labeling systems and accessories.

1.2 QUALITY ASSURANCE

- A. Refer to Section 27 00 00 for general details.

1.3 CODES, STANDARDS, AND GUIDELINES

- A. Except as modified by governing codes and by the Contract Documents, comply with the applicable provisions and recommendations in Section 27 00 00.
- B. The University Telecommunication Infrastructure Planning (UTIP) Standards document and Section 27 00 02 - APPENDIX B Labeling-Design-Syntax.

1.4 SUBMITTALS

- A. Refer to Section 27 00 00 for general details.
- B. Shop Drawings:
 - 1. Submit "nomenclature" plan/drawings for acceptance by the Cal Poly Designated Telecommunications Representative prior to labeling the insides of outdoor pull boxes, pull holes, vaults/maintenance holes and MDF, IDF, and SDF backboards.
 - 2. Prepare nomenclature for the purpose of providing conduit destination information in every pull box, pull hole and vault/maintenance hole that is to be stenciled on the wall above each conduit penetration. Encircle on the wall in black ink groups of conduits going to the same destination.
 - 3. In areas where stenciling is not possible, epoxy a Cal Poly Designated

Telecommunications Representative approved engraved "sign" with the appropriate nomenclature above the conduit penetrations.

- C. Submit Manufacturer's Cut Sheets for the following:
 - 1. Any products not specifically listed in the PRODUCTS section shall require a submittal of the manufacturer's cut sheets and approval by the Cal Poly Designated Telecommunications Representative.

1.5 IDENTIFICATION

- A. All elements (facilities, underground elements, conduits, cables, ground wires, racks, faceplates, jacks, circuits, boxes, etc.) of the telecommunications system are to be labeled.
- B. See PRODUCTS section for specific details.
- C. NOTE: The cable identification or name of fiber optic cables does not describe the cable, it only identifies or names the cable. To determine specific strand counts and cable types for each project contact the Cal Poly Designated Telecommunications Representative. After all the required cable testing is performed and the results have been reviewed and approved, the Cal Poly Designated Telecommunications Representative shall arrange for the installation of patch cables that connects all equipment and nodes to the active fiber network.

1.6 DEFINITIONS

- A. Room Number - If the location is an MDF, IDF, or SDF, the room number will be provided by others. Typically, Facilities Services, Planning and Capital Projects in concert with the Project Architect will establish a room numbering plan for the project. In remodel situations, if the location is an end user space, use its room number.
- B. Underground Facility – Maintenance holes, Hand Holes, Pull Holes and Entrance Vaults.
- C. For more detailed information see Section 27 00 02 - APPENDIX B Labeling- Design- Syntax.

1.7 WARRANTY

- A. Refer to Section 27 00 00 for general details
- B. PART 2 - PRODUCTS

2.1 PRODUCT CONSISTENCY

- A. Product Consistency: Any given item of equipment or material shall be the product of one manufacturer throughout the facility. Multiple manufacturers of any one item will not be permitted.
- B. For proper labeling information and criteria, see Section 27 00 02 - APPENDIX B Labeling-Design-Syntax.

2.2 APPROVED MANUFACTURERS AND MATERIAL

- A. See Section 27 06 00 – Schedules for Communications for approved manufacturers and material to be supplied for this section.

2.3 CABLE LABELS

- A. All labels shall be machine generated. Handwritten labels are not acceptable. (See Fig. #102 in Section 27 00 02 - APPENDIX B Labeling-Design-Syntax)
- B. Labels shall be made of durable material typically used to create permanent labels (1" white nylon with black lettering).

2.4 LABELS FOR STATION CABLES

- A. 1" white nylon with black lettering.

2.5 FACEPLATE LABELS FOR OUTLETS

- A. See Section 27 00 02 - APPENDIX B Labeling-Design-Syntax.

2.6 LABELS FOR INDOOR RACKS, CABINETS AND PANELS

- A. ½ "white polyester or nylon with black lettering (See Fig. #103 - 107 in Section 27 00 02 - APPENDIX B Labeling-Design-Syntax)
- B. See Section 27 00 02 - APPENDIX B Labeling-Design-Syntax.

2.7 LABEL PLATE FOR OUTDOOR CABINETS

- A. Anodized aluminum name plate engraved with "COMMUNICATIONS".
- B. See Section 27 00 02 - APPENDIX B Labeling-Design-Syntax.
- C. Provide Submittal for acceptance by the Cal Poly Designated Telecommunications Representative.

PART 3- EXECUTION

3.1 GENERAL

- A. Conduits
 - 1. Intrabuilding Conduits (1" white label with black lettering)

- a. Line 1: Room Number and TR ID for each end of the conduit.
 - b. Line 2: Number of this conduit related to conduits with the same two endpoints.
 - c. Label both ends of a conduit with identical tags.
 - d. See Section 27 00 02 - APPENDIX B Labeling-Design-Syntax.
2. Interbuilding Conduits (1" white labels with black lettering)
 - a. Line 1: Label with designation for the far end, Building Number and Room Number, or appropriate designation for an Underground Facility.
 - b. Line 2: Number of this conduit related to conduits with the same endpoints. Underground conduits shall be labeled as on the butterfly drawings.
 - c. Label both ends of a conduit with identical tags.
 - d. See Section 27 00 02 - APPENDIX B Labeling-Design-Syntax.
- B. Copper Cables
1. Intrabuilding Backbone Copper Cables (1" white labels with black lettering)
 - a. Line 1: Room Number or MDF, IDF, or SDF ID for each end of the cable (example: "B180-105/B180-114-1).
 - b. Line 2: Number of pairs in relation to the total between the same two endpoints Example: "PRS 1-100" or "PRS 301-400")
 - c. Label both ends of a cable with identical labels.
 - d. See Section 27 00 02 - APPENDIX B Labeling-Design-Syntax.
 2. Interbuilding Backbone Copper Cables (1" white labels with black lettering)
 - a. Line 1: Building and Room Number for each end of the cable. (Example: "B180-106/B180-532")
 - b. Line 2: Number of pairs in relation to the total between the same two endpoints.
 - c. Label both ends of a cable with identical labels.
 - d. See Section 27 00 02 - APPENDIX B Labeling-Design-Syntax.
 3. Copper Station Cable / Faceplate ID
 - a. Faceplate upper label designation:
 - 1) First number is the room the faceplate is serving.

- 2) Second number is the designation for any specific faceplate in a room.
- 3) Faceplate port label designation: (for the campus standard 4 port faceplate) (See Fig. #108 & 109 in Section 27 00 02 - APPENDIX B Labeling-Design-Syntax)
 - Upper left port: "W"
 - Upper right port: "X"
 - Lower left port: "Y"
 - Lower right port: "Z"
- b. Faceplate lower label designation:
 - 1) First word is "To:" (See Fig. #108 in Section 27 00 02 - APPENDIX B Labeling-Design-Syntax)
 - 2) Following number is the Room Number of the MDF, IDF, or SDF serving that faceplate.
- c. Examples:
 - 1) Upper label: 241-A-3 (Apartment #, Bedroom #, Faceplate #) (See Fig. #108 in Section 27 00 02 - APPENDIX B Labeling-Design-Syntax)
 - 2) 4 Port designations: W X
 - 3) Y Z
 - 4) Lower label: To: 205 (Telecomm Room Number serving this faceplate)
- d. Label both ends of a cable with identical tags.
- e. See Section 27 00 02 - APPENDIX B Labeling-Design-Syntax.
4. Copper Station Cables (1" white labels with black lettering)
 - a. Line 1: Cable designation: Room Number - Faceplate Number & Port designation
 - b. Example: "241-3W" or "241-3X" or "241-3Y" or "241-3Z" (See Fig. #107 in Section 27 00 02 - APPENDIX B Labeling-Design-Syntax)
 - c. Label both ends of a cable with identical labels.
 - d. See Section 27 00 02 - APPENDIX B Labeling-Design-Syntax.
- C. Fiber Optic Cables
 1. Intrabuilding Fiber Optic Backbone Cables (1" white labels with black lettering)

- a. Single Mode Fiber: FSB002-004/B002-192-1 (Fiber - Single Mode, from Building 002 - Room 004 / to Building 002 - Room 192 - cable 1)
 - b. Label both ends of a conduit with identical labels.
 - c. Label strand count of fiber
 - d. See Section 27 00 02 - APPENDIX B Labeling-Design-Syntax.
2. Interbuilding Fiber Optic Backbone Cables (1" white labels with black lettering)
 - a. Single Mode Fiber: FSB013-105/B011-101-1 (Fiber - Single Mode, from building 013 -Room 105 / to building 011 - Room101, cable 1)
 - b. Label both ends of a cable with identical labels.
 - c. See Section 27 00 02 - APPENDIX B Labeling-Design-Syntax.
- D. Grounding & Bonding
1. Interbuilding Grounding/Bonding Conductors (1" white labels with black lettering)
 - a. First part of line 1: Ground Type.
 - b. Second part of line 1: Room Number or MDF, IDF, or SDF ID for each end of the conductor.
 - c. Label both ends of a conductor with identical labels.
 - d. See Section 27 00 02 - APPENDIX B Labeling-Design-Syntax.
 2. Interbuilding Grounding/Bonding Conductors (1" white labels with black lettering)
 - a. First part of line 1: Ground Type.
 - b. Second part of line 1: Building Number (the lower of the two endpoint Building Numbers).
 - c. Third part of line 1: Building Number (the higher of the two endpoint Building Numbers).
 - d. Label both ends of a conductor with identical labels.
 - e. See Section 27 00 02 - APPENDIX B Labeling-Design-Syntax.
- E. Wall-field
1. All Wall-field labeling shall be created using machine generated stencils that have been approved in advance by the Cal Poly Designated

Telecommunications Representative. The labels shall be painted on the backboard in the correct locations and shall be black in color. (See Fig. #101 in Section 27 00 02 - APPENDIX B Labeling-Design-Syntax)

2. For examples see Section 27 00 02 - APPENDIX B Labeling-Design-Syntax.

F. Patch Panels

1. Label panel with correct panel ID number. (See Fig. #104 & 105 in Section 27 00 02 - APPENDIX B Labeling-Design-Syntax)
2. Label each jack with appropriate cable ID number.
3. See Section 27 00 02 - APPENDIX B Labeling-Design-Syntax.

G. Racks

1. Label front of each rack (or ladder rack above) with designated Rack Number within that MDF, IDF, or SDF. Rack Numbers start against the wall with Rack number 1 and increments as racks are added. (Using ½ inch polyester, machine generated label with black ink) (See Fig. #105 in Section 27 00 02 - APPENDIX B Labeling- Design-Syntax)
2. See Section 27 00 02 - APPENDIX B Labeling-Design-Syntax.

H. Cabinets

1. Label with "COMMUNICATIONS" (using ½ inch polyester, machine generated label with black ink)
2. See Section 27 00 02 - APPENDIX B Labeling-Design-Syntax.

3.2 QUANTITIES

- A. Quantities of system elements shown on the drawings are illustrative only and shall be meant to indicate the general configuration of the work. The Contractor shall be responsible for providing the correct quantities of materials to construct a system that meets the intent of these Specifications and the relevant codes.

3.3 INSTALLATION

- A. Installation of all identification type products shall be as detailed in this section, as shown in Section 27 00 02 - APPENDIX B Labeling-Design-Syntax, and as per the manufacturer's printed information. All engraved labels shall be attached mechanically (adhesives may be used in addition) using hardware appropriate for maintaining long- term attachment.

3.4 GROUNDING AND BONDING

A. N/A

3.5 TESTING

A. N/A

3.6 ACCEPTANCE

A. Once the testing has been completed and the Cal Poly Designated Telecommunications Representative is satisfied that all work is in accordance with the Contract Documents, the representative will notify the Contractor and/or the Cal Poly Facilities Project Manager in writing or via email.

3.7 RECORD (AS-BUILT) DRAWINGS

A. None

Required END OF SECTION

Master Pre-Approved Product, Material, or Manufacturer List Index

Important Notes

1. SUBMITTALS REQUIRED - See specifications, Section 27 00 00, PART 1 - GENERAL, SUBMITTALS.
2. Any submittal of an "or equal" product must contain the product manufacturer's performance specifications cut sheet for that product.
3. Items not showing manufacturer and part # shall be furnished by the Contractor with submittal approval by the Cal Poly Designated Telecommunications Representative.
4. Not all items listed are necessarily required for this project
5. If Line #s appear not to be sequential, those items have been removed since they are not required for this project.

Line #	Division 27 Section Number	Division 27 Section Name	Approved Manufacturer	Part #	As Specified, Or Equal	Description
1	27 00 00	Communications	3M/SCOTCH	TEMPFLEX 1700	Or Equal	ELECTRICAL TAPE, VINYL, BLACK, 3/4" x 66'
2	27 00 00	Communications	VELCRO	31086		VELCRO, BLACK, 3/4", 25 YARD ROLL, ONE-WAY TAPE
3	27 05 26	Grounding and Bonding for Communications Systems	3M/SCOTCH	4460-d		Shield bond connector
4	27 05 26	Grounding and Bonding for Communications Systems	Chatsworth			
5	27 05 26	Grounding and Bonding for Communications Systems	CPI	40153-012	Or Equal	BICSI & ANSI/EIA/TIA GROUNDING BUSBAR 12"
6	27 05 26	Grounding and Bonding for Communications Systems	CPI	40159-001	Or Equal	GROUND WIRE, #6, GREEN INSULATED, 100FT SPOOL
7	27 05 26	Grounding and Bonding for Communications Systems	CPI	40162-951	Or Equal	TWO HOLE COMPRESSION LUGS, 25 EACH
8	27 05 26	Grounding and Bonding for Communications Systems	CPI	40164-001		CABLE RUNWAY GROUND STRAP KIT, 1 EACH
9	27 05 26	Grounding and Bonding for Communications Systems	CPI	40164-025		CABLE RUNWAY GROUND STRAP KIT, 25 EACH
10	27 05 26	Grounding and Bonding for Communications Systems	Thomas & Betts			
11	27 05 33	Conduits and Backboxes for Communications Systems	American Fittings Corp			
12	27 05 33	Conduits and Backboxes for Communications Systems	Appleton			
13	27 05 33	Conduits and Backboxes for Communications Systems	CADDY	CAT32HP	Or Equal	J-HOOKS, WITH BUILT IN RETAINER, 2"
14	27 05 33	Conduits and Backboxes for Communications Systems	CADDY	CAT48HP	Or Equal	J-HOOKS, WITH BUILT IN RETAINER, 3"
15	27 05 33	Conduits and Backboxes for Communications Systems	CADDY	CAT64HP	Or Equal	J-HOOKS, WITH BUILT IN RETAINER, 4", BOX 100
16	27 05 33	Conduits and Backboxes for Communications Systems	CADDY	CAT425A6	Or Equal	CABLE SACKS, PLENUM RATED
17	27 05 33	Conduits and Backboxes for Communications Systems	COMMSCOPE	1-2111008-3	Or Equal	SL SERIES FACEPLATE, ALPINE WHITE, WITH LABEL WINDOWS, 1 PORT
18	27 05 33	Conduits and Backboxes for Communications Systems	COMMSCOPE	1-2111009-3	Or Equal	SL SERIES FACEPLATE, ALPINE WHITE, WITH LABEL WINDOWS, 2 PORT

Master Pre-Approved Product, Material, or Manufacturer List Index

Important Notes

1. SUBMITTALS REQUIRED - See specifications, Section 27 00 00, PART 1 - GENERAL, SUBMITTALS.
2. Any submittal of an "or equal" product must contain the product manufacturer's performance specifications cut sheet for that product.
3. Items not showing manufacturer and part # shall be furnished by the Contractor with submittal approval by the Cal Poly Designated Telecommunications Representative.
4. Not all items listed are necessarily required for this project
5. If Line #s appear not to be sequential, those items have been removed since they are not required for this project.

Line #	Division 27 Section Number	Division 27 Section Name	Approved Manufacturer	Part #	As Specified, Or Equal	Description
19	27 05 33	Conduits and Backboxes for Communications Systems	COMMSCOPE	1-2111010-3	Or Equal	SL SERIES FACEPLATE, ALPINE WHITE, WITH LABEL WINDOWS, 3 PORT
20	27 05 33	Conduits and Backboxes for Communications Systems	COMMSCOPE	1-2111011-3	Or Equal	SL SERIES FACEPLATE, ALPINE WHITE, WITH LABEL WINDOWS, 4 PORT
21	27 05 33	Conduits and Backboxes for Communications Systems	COMMSCOPE	1-1116412-3	Or Equal	SL SERIES FACEPLATE BLANK INSERT, ALPINE WHITE
22	27 05 33	Conduits and Backboxes for Communications Systems	COMMSCOPE	1-1116698-3	Or Equal	SL SERIES 2 PORT BOX ("BISCUIT"), ALPINE WHITE
23	27 05 33	Conduits and Backboxes for Communications Systems	COMMSCOPE	1-1479784-3	Or Equal	SL SERIES, DÉCORA FRAMES, ALPINE WHITE, 2 PORT
24	27 05 33	Conduits and Backboxes for Communications Systems	COMMSCOPE	1-1479504-3	Or Equal	SL SERIES, DÉCORA FRAMES, ALPINE WHITE, 4 PORT
25	27 05 33	Conduits and Backboxes for Communications Systems	COMMSCOPE	558107-1	Or Equal	FURNITURE FACEPATE, THREE PORT, BLACK
26	27 05 33	Conduits and Backboxes for Communications Systems	Legrand/Wiremold			Evolution Series Floor Box
27	27 05 33	Conduits and Backboxes for Communications Systems	Thomas & Betts			
28	27 05 36	Cable Trays for Communications Systems	Cooper Industries			
29	27 05 36	Cable Trays for Communications Systems	Cope Trof			
30	27 05 36	Cable Trays for Communications Systems	Snake Tray			
31	27 05 37	Firestopping Systems for Communications Cabling	3M			
32	27 05 37	Firestopping Systems for Communications Cabling	Hilti			
33	27 05 37	Firestopping Systems for Communications Cabling	Specified Technologies Inc.			EZ Path Series 22, 33, or 44
34	27 05 39	Surface Raceways for Communications Systems	Legrand/Wiremold	2000		
35	27 05 39	Surface Raceways for Communications Systems	Legrand/Wiremold	4000		
36	27 05 39	Surface Raceways for Communications Systems	WIREMOLD	V4050		DEVICE MOUNTING BRACKET
37	27 05 39	Surface Raceways for Communications Systems	WIREMOLD	CM-ARA		RACEWAY ADAPTOR
38	27 05 39	Surface Raceways for Communications Systems	WIREMOLD	CM-2-U2AMP		DUAL MODULE
39	27 05 43	Underground Ducts and Raceways for Comm Systems	Bilco Company (The)			SIGNAL PULL HOLE (SPH), SIGNAL PULL BOX (SPB), SIGNAL MANHOLE (SMH), and Utility Structure Accessories

Master Pre-Approved Product, Material, or Manufacturer List Index

Important Notes

1. SUBMITTALS REQUIRED - See specifications, Section 27 00 00, PART 1 - GENERAL, SUBMITTALS.
2. Any submittal of an "or equal" product must contain the product manufacturer's performance specifications cut sheet for that product.
3. Items not showing manufacturer and part # shall be furnished by the Contractor with submittal approval by the Cal Poly Designated Telecommunications Representative.
4. Not all items listed are necessarily required for this project
5. If Line #s appear not to be sequential, those items have been removed since they are not required for this project.

Line #	Division 27 Section Number	Division 27 Section Name	Approved Manufacturer	Part #	As Specified, Or Equal	Description
40	27 05 43	Underground Ducts and Raceways for Comm Systems	Campbell Foundry Company			SIGNAL PULL HOLE (SPH), SIGNAL PULL BOX (SPB), SIGNAL MANHOLE (SMH), and Utility Structure Accessories
41	27 05 43	Underground Ducts and Raceways for Comm Systems	Carlou Electrical Products			NONMETALLIC DUCTS AND DUCT ACCESSORIES
42	27 05 43	Underground Ducts and Raceways for Comm Systems	CDT; a division of Cable Design Technologies			NONMETALLIC DUCTS AND DUCT ACCESSORIES
43	27 05 43	Underground Ducts and Raceways for Comm Systems	Cherne Industries, Inc.	Gripper		DUCT SEAL (UNPOPULATED CONDUITS)
44	27 05 43	Underground Ducts and Raceways for Comm Systems	Christy Concrete Products			SIGNAL PULL HOLE (SPH), SIGNAL PULL BOX (SPB), SIGNAL MANHOLE (SMH), and Utility Structure Accessories
45	27 05 43	Underground Ducts and Raceways for Comm Systems	Gardner Bender	DS-130		DUCT SEAL (CONDUITS POPULATED WITH CABLING)
46	27 05 43	Underground Ducts and Raceways for Comm Systems	Lamson & Sessions			NONMETALLIC DUCTS AND DUCT ACCESSORIES
47	27 05 43	Underground Ducts and Raceways for Comm Systems	Oldcastle Precast Group			SIGNAL PULL HOLE (SPH), SIGNAL PULL BOX (SPB), SIGNAL MANHOLE (SMH), and Utility Structure Accessories
48	27 05 43	Underground Ducts and Raceways for Comm Systems	Spiraduct/AFC Cable Systems, Inc			NONMETALLIC DUCTS AND DUCT ACCESSORIES
49	27 05 43	Underground Ducts and Raceways for Comm Systems	Utility Concrete Products, LLC			SIGNAL PULL HOLE (SPH), SIGNAL PULL BOX (SPB), SIGNAL MANHOLE (SMH), and Utility Structure Accessories
50	27 05 43	Underground Ducts and Raceways for Comm Systems	Utility Vault Co			SIGNAL PULL HOLE (SPH), SIGNAL PULL BOX (SPB), SIGNAL MANHOLE (SMH), and Utility Structure Accessories
51	27 05 53	Identification for Communications Systems	3M			
52	27 05 53	Identification for Communications Systems	DYMO			
53	27 08 13	Testing of Copper Cables	Fluke Networks	LinkWare		LinkWare software
54	27 08 23	Testing of Fiber Optic Cables	Fluke Networks	LinkWare		SimpliFiber
55	27 08 23	Testing of Fiber Optic Cables	Fluke Networks	LinkWare		OMNIScanner w/ Fiber Test Adapters
56	27 08 23	Testing of Fiber Optic Cables	Fluke Networks	LinkWare		Fiber Inspector Pro Inspection Scope
57	27 11 00	Communications Equipment Room Fittings	Cherne Industries, Inc.			DUCT SEAL (UNPOPULATED CONDUITS)
58	27 11 00	Communications Equipment Room Fittings	CPI	12100-718	Or Equal	RADIUS DROP, 17", BLACK
59	27 11 00	Communications Equipment Room Fittings	CPI	12101-718	Or Equal	RADIUS DROP, ADJUSTABLE, BLACK
60	27 11 00	Communications Equipment Room Fittings	CPI	12103-108	Or Equal	RADIUS DROP, 5", BLACK
61	27 11 00	Communications Equipment Room Fittings	CPI	10250-712	Or Equal	LADDER RACEWAY, 12", BLACK
62	27 11 00	Communications Equipment Room Fittings	CPI	11302-701	Or Equal	LADDER TRAY JUNCTION-SPLICE KIT

Master Pre-Approved Product, Material, or Manufacturer List Index

Important Notes

1. SUBMITTALS REQUIRED - See specifications, Section 27 00 00, PART 1 - GENERAL, SUBMITTALS.
2. Any submittal of an "or equal" product must contain the product manufacturer's performance specifications cut sheet for that product.
3. Items not showing manufacturer and part # shall be furnished by the Contractor with submittal approval by the Cal Poly Designated Telecommunications Representative.
4. Not all items listed are necessarily required for this project
5. If Line #s appear not to be sequential, those items have been removed since they are not required for this project.

Line #	Division 27 Section Number	Division 27 Section Name	Approved Manufacturer	Part #	As Specified, Or Equal	Description
63	27 11 00	Communications Equipment Room Fittings	CPI	10487-701	Or Equal	LADDER TRAY SWIVEL SPLICE KIT
64	27 11 00	Communications Equipment Room Fittings	CPI	10595-712	Or Equal	3" CHANNEL RACK-TO-RUNWAY MOUNTING PLATE 9-12"
65	27 11 00	Communications Equipment Room Fittings	CPI	11729-703	Or Equal	2 SIDED WIDE VERTICAL CABLING SECTION, 7FT, 6" WIDE
66	27 11 00	Communications Equipment Room Fittings	CPI	11746-712	Or Equal	TRIANGULAR SUPPORT BRACKET, STEEL 12"
67	27 11 00	Communications Equipment Room Fittings	CPI	10250-718	Or Equal	18" LADDER TRAY BLACK
68	27 11 00	Communications Equipment Room Fittings	CPI	10250-724	Or Equal	24" LADDER TRAY BLACK
69	27 11 00	Communications Equipment Room Fittings	CPI	11301-701	Or Equal	LADDER TRAY BUTT-SPLICE
70	27 11 00	Communications Equipment Room Fittings	CPI	11959-715	Or Equal	LADDER TRAY CABLE RUNWAY CORNER BRACKET 15"
71	27 11 00	Communications Equipment Room Fittings	CPI	10595-718	Or Equal	3" CHANNEL RACK-TO-RUNWAY MOUNTING PLATE 15-18"
72	27 11 00	Communications Equipment Room Fittings	CPI	10506-702	Or Equal	CABLE RUNWAY ELEVATION KIT 2-3" RISE
73	27 11 00	Communications Equipment Room Fittings	CPI	10506-706	Or Equal	CABLE RUNWAY ELEVATION KIT 4-6" RISE
74	27 11 00	Communications Equipment Room Fittings	CPI	10506-708	Or Equal	CABLE RUNWAY ELEVATION KIT 10-12" RISE
75	27 11 00	Communications Equipment Room Fittings	CPI	11746-718	Or Equal	TRIANGULAR SUPPORT BRACKET, STEEL 18"
76	27 11 00	Communications Equipment Room Fittings	CPI	11746-724		TRIANGULAR SUPPORT BRACKET, STEEL 24"
77	27 11 00	Communications Equipment Room Fittings	CPI	11421-712		WALL ANGLE SUPPORT KIT, CABLE RUNWAY 12"
78	27 11 00	Communications Equipment Room Fittings	CPI	11421-718		WALL ANGLE SUPPORT KIT, CABLE RUNWAY 18"
79	27 11 00	Communications Equipment Room Fittings	CPI	11421-724		WALL ANGLE SUPPORT KIT, CABLE RUNWAY 24"
80	27 11 00	Communications Equipment Room Fittings	CPI	10608-701		VERTICAL WALL BRACKETS
81	27 11 00	Communications Equipment Room Fittings	CPI	10642-001		PROTECTIVE END CAPS FOR RUNWAY
82	27 11 00	Communications Equipment Room Fittings	DYNACOM/PRIMUS	DY-S187B1M		DISTRIBUTION SPOOLS, FULL BOARD, METAL
83	27 11 00	Communications Equipment Room Fittings	DYNACOM/PRIMUS	SKU: PP7-2143-MUSH		DISTRIBUTION SPOOL, WITHOUT SCREW
84	27 11 00	Communications Equipment Room Fittings	Gardner Bender			DUCT SEAL (CONDUITS POPULATED WITH CABLING)
85	27 11 00	Communications Equipment Room Fittings	Osborne Associates Inc.			DUCT SEAL (UNPOPULATED CONDUITS)
86	27 11 13	Communications Entrance Protection	3M	K&B Series		Building Riser Closure
87	27 11 13	Communications Entrance Protection	CIRCA	S26100QC/QC	Or Equal	BUILDING ENTRANCE PROTECTOR, 100 PAIR
88	27 11 13	Communications Entrance Protection	CIRCA	3B1E	Or Equal	GAS TYPE FUSES FOR PROTECTOR, ANALOG
89	27 11 13	Communications Entrance Protection	CIRCA	4B1EW	Or Equal	GAS TYPE FUSES FOR PROTECTOR, DIGITAL
90	27 11 13	Communications Entrance Protection	Commscope	489 Series		Building Entrance Terminal
91	27 11 13	Communications Entrance Protection	Commscope			Entrance Protector for Horizontal Copper UTP OSP Station Cable (Data)

Master Pre-Approved Product, Material, or Manufacturer List Index

Important Notes

1. SUBMITTALS REQUIRED - See specifications, Section 27 00 00, PART 1 - GENERAL, SUBMITTALS.
2. Any submittal of an "or equal" product must contain the product manufacturer's performance specifications cut sheet for that product.
3. Items not showing manufacturer and part # shall be furnished by the Contractor with submittal approval by the Cal Poly Designated Telecommunications Representative.
4. Not all items listed are necessarily required for this project
5. If Line #s appear not to be sequential, those items have been removed since they are not required for this project.

Line #	Division 27 Section Number	Division 27 Section Name	Approved Manufacturer	Part #	As Specified, Or Equal	Description
92	27 11 13	Communications Entrance Protection	Commscope Systimax			Surge Protection Module
93	27 11 13	Communications Entrance Protection	Dymo			1" White labeling with machine generated black lettering
94	27 11 13	Communications Entrance Protection	Lucent			Entrance Protector for Horizontal Copper UTP OSP Station Cable (Data)
95	27 11 13	Communications Entrance Protection	Marconi			Entrance Protector for Horizontal Copper UTP OSP Station Cable (Data)
96	27 11 13	Communications Entrance Protection	Porta Systems			Entrance Protector for Horizontal Copper UTP OSP Station Cable (Voice)
97	27 11 13	Communications Entrance Protection	Tii Network Technologies			Entrance Protector for Horizontal Copper UTP OSP Station Cable (Voice)
98	27 11 16	Communications Cabinets, Racks, Frames and Enclosures	COMMSCOPE	CPP-UDDM-SL-1U-24	Or Equal	24 PORT JACK PANEL, SL SERIES JACKS
99	27 11 16	Communications Cabinets, Racks, Frames and Enclosures	COMMSCOPE	CPP-UDDM-SL-2U-48	Or Equal	48 PORT JACK PANEL, SL SERIES JACKS
100	27 11 16	Communications Cabinets, Racks, Frames and Enclosures	LEVITON	49253-LPM		1U HORIZONTAL WIRE MANAGERS
101	27 11 16	Communications Termination Blocks and Patch Panels	LEVITON	49253-BCM		2U HORIZONTAL WIRE MANAGERS
102	27 11 19	Communications Cabinets, Racks, Frames and Enclosures	CPI	55053-703	Or Equal	2 POST RACK, 19", 7FT, BLACK WITH BONDING LUGS
103	27 11 19	Communications Cabinets, Racks, Frames and Enclosures	HILTI	387513		ANCHORS (REDHEADS)
104	27 11 19	Communications Termination Blocks and Patch Panels	ALLEN-TEL	AT55N-PNL-48	Or Equal	48 PORT CAT 5E PATCH PANEL, 110 TERMINATION IDC
105	27 11 20	Communications Fiber Termination and Patch Panels	CORNING	CCH-04U	Or Equal	4U FIBER LIU, HOLDS 12 CCH MODULES
106	27 11 20	Communications Fiber Termination and Patch Panels	CORNING	CCH-CS24-AE-P00RE	Or Equal	SPLICE CASSET, 24 STRAND, LC, MODULE
107	27 11 20	Communications Fiber Termination and Patch Panels	FIS	F1-8729G		FIBER OPTIC SPLICE TRAYS, 4"W x 11"L
108	27 11 20	Communications Fiber Termination and Patch Panels	FIS	F11002C-50		FIBER SPLICE PROTECTION SHRINK SLEEVES, 60MM, PKG 50
109	27 11 20	Communications Fiber Termination and Patch Panels	FIS	dsp12lcupcbu		FIBER PIGTAILS 6FT, SINGLE MODE, 12 STRAND/12 COLORS, LCupc

Master Pre-Approved Product, Material, or Manufacturer List Index

Important Notes

1. SUBMITTALS REQUIRED - See specifications, Section 27 00 00, PART 1 - GENERAL, SUBMITTALS.
2. Any submittal of an "or equal" product must contain the product manufacturer's performance specifications cut sheet for that product.
3. Items not showing manufacturer and part # shall be furnished by the Contractor with submittal approval by the Cal Poly Designated Telecommunications Representative.
4. Not all items listed are necessarily required for this project
5. If Line #s appear not to be sequential, those items have been removed since they are not required for this project.

Line #	Division 27 Section Number	Division 27 Section Name	Approved Manufacturer	Part #	As Specified, Or Equal	Description
110	27 11 20	Communications Fiber Termination and Patch Panels	FIS	SCXXS012D006F S9		FIBER PIGTAILS 6FT, SINGLE MODE, 12 STRAND/12 COLORS, SCupc
111	27 11 20	Communications Fiber Termination and Patch Panels	PANDUIT	FRME4		4U FIBER LIU
112	27 11 20	Communications Fiber Termination and Patch Panels	PANDUIT	FMRE2		2U FIBER LIU, SPLICE CENTER
113	27 11 20	Communications Fiber Termination and Patch Panels	PANDUIT	FAP12WBUDLCZ		LCupc DUPLEX BULKHEAD ADAPTOR PANEL, 24 FIBER
114	27 11 23	Communication Cable Management and Ladder Rack	Chatsworth Products Inc.			Ladder Rack and connecting hardware
115	27 11 23	Communication Cable Management and Ladder Rack	Panduit			Cable Ties (Outdoor)
116	27 11 23	Communication Cable Management and Ladder Rack	Panduit			Cable Ties Mount
117	27 11 23	Communication Cable Management and Ladder Rack	Rip-Tie			Cable Straps
118	27 12 24	Communication Optical OSP Cabling	Commscope			Multimode Optical Fiber OSP Cable - Black Jacket
119	27 12 24	Communication Optical OSP Cabling	Commscope			Multimode Optical Fiber Indoor/Outdoor Cable - Black Jacket
120	27 12 24	Communication Optical OSP Cabling	Commscope			Singlemode Optical Fiber OSP Cable - Black Jacket
121	27 12 24	Communication Optical OSP Cabling	Commscope			Singlemode Optical Fiber Indoor/Outdoor Cable - Black
122	27 12 24	Communication Optical OSP Cabling	Corning			Multimode Optical Fiber OSP Cable - Black Jacket
123	27 12 24	Communication Optical OSP Cabling	Corning			Singlemode Optical Fiber OSP Cable - Black Jacket
124	27 13 13	Communications Copper Backbone Cabling	Superior Essex			Copper backbone cabling
125	27 13 14	Communications Copper OSP Cabling	Commscope			Copper Cat 6A OSP station cabling
126	27 13 14	Communications Copper OSP Cabling	COMMSCOPE	6O4P24-BK-R-CMSNR	Or Equal	CAT6, 4-PAIR, OSP-RATED CABLE
127	27 13 14	Communications Copper OSP Cabling	Superior Essex			Copper OSP cabling
128	27 13 14	Communications Copper OSP Cabling	Superior Essex			Copper Cat 3 OSP station cabling
129	27 13 23	Communications Optical Fiber Backbone Cabling	Berk-Tek	3P25P24-BL-R-BERPP	Or Equal	25-PAIR PLENUM CAT3 24AWG
130	27 13 23	Communications Optical Fiber Backbone Cabling	Commscope			Optical Fiber Plenum Riser Cable
131	27 13 23	Communications Optical Fiber Backbone Cabling	CORNING	012ESF-T4101D20	Or Equal	12 COUNT SM FREEDM/LST INDOOR/OUTDOOR RISER RATED FIBER

Master Pre-Approved Product, Material, or Manufacturer List Index

Important Notes

1. SUBMITTALS REQUIRED - See specifications, Section 27 00 00, PART 1 - GENERAL, SUBMITTALS.
2. Any submittal of an "or equal" product must contain the product manufacturer's performance specifications cut sheet for that product.
3. Items not showing manufacturer and part # shall be furnished by the Contractor with submittal approval by the Cal Poly Designated Telecommunications Representative.
4. Not all items listed are necessarily required for this project
5. If Line #s appear not to be sequential, those items have been removed since they are not required for this project.

Line #	Division 27 Section Number	Division 27 Section Name	Approved Manufacturer	Part #	As Specified, Or Equal	Description
132	27 13 23	Communications Optical Fiber Backbone Cabling	CORNING (FREEDM)	024ESF-T4101D20	Or Equal	SINGLE MODE FIBER, 24 CORE, PLENUM
133	27 13 23	Communications Optical Fiber Backbone Cabling	SIEMON	66M1-50		66 BLOCK, 50-PAIR
134	27 13 23	Communications Optical Fiber Backbone Cabling	SIEMON	S89B		66 BLOCK STANDOFF
135	27 13 23	Communications Optical Fiber Backbone Cabling	SUPERIOR-ESSEX	DB-25P24-AL-89-5K-ESS		25-PAIR 24AWG OSP/UTP w/SHIELD
136	27 13 23	Communications Optical Fiber Backbone Cabling	SUPERIOR-ESSEX	D8UD0424-101		CROSS-CONNECT WIRE, 1 PR, 24AWG, YL/BL, 1000'
137	27 13 23	Communications Optical Fiber Backbone Cabling	SUPERIOR-ESSEX	02-002-13 / Anixter #J-		CROSS-CONNECT WIRE, 1 PR, 24AWG, YL/BL, 1000'
138	27 13 23	Communications Optical Fiber Backbone Cabling	SUPERIOR-ESSEX	RC50P24-GY-R-ESS		50-PAIR, 24AWG, ARMM UTP CABLE
139	27 13 24	Communications Optical Fiber OSP Cabling	CORNING (FREEDM)	096ESF-T4101D20	Or Equal	96 STRAND SINGLE MODE FIBER, OSP, LOOSE TUBE
140	27 13 24	Communications Optical Fiber OSP Cabling	ENDOT	166/11		INNERDUCT, 1-1/4", SMOOTH WALL, ORANGE
141	27 13 24	Communications Optical Fiber OSP Cabling	GREENLEE	4435		MULE TAPE, 3000' REEL, 1/2"W, 1250lbs. TENSILE STRENGTH
142	27 13 24	Communications Optical Fiber OSP Cabling	HILTI	CP-618		FIRE RATED DUCT SEAL
143	27 13 24	Communications Optical Fiber OSP Cabling	HUBBELL	FOSPCW14		FIBER SERVICE LOOP WHEELS 14"
144	27 13 24	Communications Optical Fiber OSP Cabling	IDEAL	31-601		DUCT SEAL, GREY, BOX OF 10 BARS
145	27 13 24	Communications Optical Fiber OSP Cabling	OBERON	1020-00		NEMA 4 WEATHER-PROOF ENCLOSURE (WAP)
146	27 15 13	Structured Cable System	AMP			Cat 6A Horizontal Cable
147	27 15 13	Structured Cable System	Belden			Cat 6A Horizontal Cable
148	27 15 13	Structured Cable System	Belkin			Cat 6A Horizontal Cable
149	27 15 13	Structured Cable System	Commscope			Cat 6A Horizontal Cable
150	27 15 13	Structured Cable System	COMMSCOPE	760237627	Or Equal	JACK, RJ-45, CAT6, SL SERIES, BLACK
151	27 15 13	Structured Cable System	COMMSCOPE	760237636	Or Equal	JACK, RJ-45, CAT6, SL SERIES, IVORY
152	27 15 13	Structured Cable System	COMMSCOPE	760237629	Or Equal	JACK, RJ-45, CAT6, SL SERIES, ALPINE WHITE
153	27 15 13	Structured Cable System	COMMSCOPE	760237630	Or Equal	JACK, RJ-45, CAT6, SL SERIES, GREEN
154	27 15 13	Structured Cable System	COMMSCOPE	760237633	Or Equal	JACK, RJ-45, CAT6, SL SERIES, YELLOW

SECTION 27 08 13 – TESTING OF COPPER CABLES

PART 1 - GENERAL

1.1 DESCRIPTION

- A. The work covered by this section of the Specifications includes all labor necessary to perform and complete such construction, all materials and equipment incorporated or to be incorporated in such construction and all services, facilities, tools, and equipment necessary or used to perform a complete installation of the Telecommunications Systems and Components. The work of this section shall include, but is not limited to, the following:
 - 1. Cable testing for copper cables.
 - 2. Providing testing results in accordance with the strictest manufacturers' written recommendations.

1.2 QUALITY ASSURANCE

- A. Refer to Section 27 00 00 for general details.

1.3 CODES, STANDARDS, AND GUIDELINES

- A. Except as modified by governing codes and by the Contract Documents, comply with the applicable provisions and recommendations in Section 27 00 00.
- B. The University Telecommunication Infrastructure Planning (UTIP) Standards document and Section 27 00 02 - APPENDIX B Labeling-Design-Syntax.

1.4 SUBMITTALS

- A. Refer to Section 27 00 00 for general details.
- B. Shop Drawings:
 - 1. None Required
- C. Submit Manufacturer's Cut Sheets for the following:
 - 1. Any products not specifically listed in the PRODUCTS section shall require a submittal of the manufacturer's cut sheets and approval by the Cal Poly Designated Telecommunications Representative.
- D. List of test equipment to be used.

- E. Sample of test data to be provided to the Cal Poly Designated Telecommunications Representative prior to the start of testing for review, comment, and acceptance.
- F. Identity and qualifications of Contractor's personnel who will perform the testing.
- G. Submit the proposed schedule for performing testing at least 2 weeks prior to the start of testing.

1.5 IDENTIFICATION

- A. For details, refer to Section 27 05 53 and Section 27 00 02 - APPENDIX B Labeling- Design-Syntax.

1.6 DEFINITIONS

- A. N/A

1.7 WARRANTY

- A. Refer to Section 27 00 00 for general

details. PART 2 - PRODUCTS

2.1 PRODUCT CONSISTENCY

- A. N/A

2.2 APPROVED MANUFACTURERS AND MATERIAL

- A. See Section 27 06 00 – Schedules for Communications for approved manufacturers and material to be supplied for this section.

2.3 CATEGORY 3 UTP CABLE TESTER

- A. Testing for all cables 25 pair or larger are to use a tester that tests 25 pair at a time.
- B. The field tester must meet the requirements of ANSI/TIA/EIA-568.
- C. Make and model to be submitted for approval by the Cal Poly Designated Telecommunications Representative prior to start of testing.

2.4 CATEGORY 6 or 6A UTP CABLE TESTER

- A. The field tester must meet the requirements of ANSI/TIA/EIA-568-B.2, Addendum 1
- B. Tester must output test results with Fluke's LinkWare reporting software. PDF format is unacceptable. Alternate reporting software may be used if the associated software (with license if required) is given to the Cal Poly Designated Telecommunications Representative. (Software not to be returned)
- C. Make and model to be submitted for approval by the Cal Poly

Designated Telecommunications Representative prior to start of testing.

2.5 MULTIMETER

- A. Make and model at Contractor's discretion with the Cal Poly Designated Telecommunications Representative approval.

2.6 CATV COAX TESTER

- A. Test equipment for the CATV coax wiring must provide TDR and sweep test

information. PART 3- EXECUTION

3.1 GENERAL

- A. The Contractor shall test, as described below, all metallic cables installed under these specifications.
- B. Visually inspect all cables, cable reels, and shipping cartons to detect cable damage incurred during shipping and transport. Return visibly damaged items to the manufacturer.
- C. Where post-manufacturer test data has been provided by the manufacturer on the reel or shipping carton: Submit 2 copies to the Cal Poly Designated Telecommunications Representative prior to installing cables.
- D. Test fully completed systems only. Piecemeal testing is not acceptable.
- E. Testing shall not be performed until after all termination hardware is installed and attached, and all labeling and identification has been completed. If all work is not completed prior to testing, test data will be considered not acceptable and shall be redone and resubmitted.
- F. Any cable that does not pass all required testing shall be removed, replaced, and retested.
- G. Remove and replace any defective cables from pathways system. Do not abandon cables in place.
- H. For 100 pair or smaller replace entire cable if a pair or conductor fails a required test. For larger pair count cables, replace if more than 2% of pairs fail a required test.
- I. The Cal Poly Designated Telecommunications Representative reserves the right to observe all portions of the testing process.
- J. The Cal Poly Designated Telecommunications Representative further reserves the right to conduct "Proof of performance testing," using Contractor

equipment and labor. This shall be a random re-test of up to ten percent (10%) of the cable plant to confirm documented test results. If multiple errors are found, test percentages shall rise.

- K. Perform all tests as required by the manufacturer in support of the structured cabling system warranty.

3.2 QUANTITIES

- A. N/A

3.3 INSTALLATION

- A. N/A

3.4 GROUNDING AND BONDING

- A. All grounding and bonding is to be complete before any system testing is to be attempted.

3.5 TESTING

- A. All test results are to be defined as acceptable / unacceptable using the requirements of ANSI/TIA/EIA-568 B.

- B. Copper Cables - General Requirements

1. After terminating and splicing all cables, test all cable pairs for:
 - a. Continuity to the remote end.
 - b. Shorts between any 2 or more conductors or ground
 - c. Transposed pairs
 - d. Reversed Pairs
 - e. Split Pairs
 - f. Crossed Pairs
 - g. Wire map.
 - h. Length.
 - i. Shield Continuity (If shielded)
 - j. Continuity to Grounding (If shielded)
2. Using a (low ohm) multimeter, test continuity to ground (PBB or SBB) for a maximum resistance of 1 ohm, see section 27 05 26 for additional detail.

- C. Indoor Riser or OSP Copper Cable

1. After terminating and splicing the cables. Test all cable pairs for:
 - a. DC Loop Resistance for any 2 conductors in the cable
- D. Category 6 or 6A Copper Station Cables:
 1. After terminating both ends of all 4-pair cables, but before any equipment is installed, test these cables for the following:
 - a. Return Loss
 - b. Insertion Loss
 - c. Attenuation
 - d. NEXT (near-end crosstalk)
 - e. PSNEXT (power sum near-end crosstalk)
 - f. FEXT (far end crosstalk)
 - g. ACR-F (attenuation to crosstalk ratio)
 - h. PSACR-F (power sum attenuation to crosstalk ratio)
 - i. Propagation delay
 - j. Delay skew
 - k. Cable length

3.6 ACCEPTANCE

- A. All test results for CAT 3 cable are to be documented and submitted in the Manufacturer's native format to the Cal Poly Designated Telecommunications Representative (electronically) within five (5) working days of test completion. Alternate reporting software may be used if the associated software (with license if required) is given to the Cal Poly Designated Telecommunications Representative. (Software not to be returned)
- B. All test results for CAT 6 or 6A cable to be documented and submitted in Fluke LinkWare files and PDF format to the Cal Poly Designated Telecommunications Representative electronically within five (5) working days of test completion. Results shall also include graphs and data results. Alternate reporting software may be used if the associated software (with license if required) is given to the Cal Poly Designated Telecommunications Representative. (Software not to be returned)
- C. Test result shall be recorded per cable and final digital files to be delivered to the Cal Poly Designated Telecommunications Representative for review and acceptance. If test results are found acceptable, the Cal Poly Designated

Telecommunications Representative shall inform the Cal Poly Facilities Project Manager in writing or by email.

- D. Each test report shall contain the following general information:
 - 1. Date of Preparation.
 - 2. Date of Test.
 - 3. Project Name (Cal Poly building number).
 - 4. Contractor's Name & Certification
 - 5. Media Type.
 - 6. Make, Model and Serial Number of test equipment used.
 - 7. Date of Last Calibration.
 - 8. Names of Test Crew & Certification.
- E. In addition to the results of the specific tests specified, reports shall also include:
 - 1. Cable ID Number (see Section 27 00 02 - APPENDIX B Labeling-Design-Syntax).
 - 2. Cable Type.
 - 3. Pair or Conductor Count.
 - 4. Individual Pair or Conductor Numbers.
 - 5. Results of Each Test for Each Pair or Conductor.
 - 6. Total Number of Serviceable Pairs or Conductors in Cable.
 - 7. Ground Resistance Measurements.
- F. Once the testing has been completed and the Cal Poly Designated Telecommunications Representative is satisfied that all work is in accordance with the Contract Documents, the representative will notify the Contractor and/or the Cal Poly Facilities Project Manager in writing or via email.

3.7 RECORD (AS-BUILT) DRAWINGS

- A. None

Required END OF SECTION

SECTION 27 08 23 – TESTING OF FIBER OPTIC CABLES

PART 1 - GENERAL

1.1 DESCRIPTION

- A. The work covered by this section of the Specifications includes all labor necessary to perform and complete such construction, all materials and equipment incorporated or to be incorporated in such construction and all services, facilities, tools and equipment necessary or used to perform a complete installation of the Telecommunications Systems and Components. The work of this section shall include, but is not limited to, the following:
 - 1. Cable testing for fiber optic cables.
 - 2. Providing testing results in accordance with the strictest manufacturer written recommendations.

1.2 QUALITY ASSURANCE

- A. Refer to Section 27 00 00 for general details.

1.3 CODES, STANDARDS, AND GUIDELINES

- A. Except as modified by governing codes and by the Contract Documents, comply with the applicable provisions and recommendations in Section 27 00 00.
- B. The University Telecommunication Infrastructure Planning (UTIP) Standards document and Section 27 00 02 - APPENDIX B Labeling-Design-Syntax.

1.4 SUBMITTALS

- A. Refer to Section 27 00 00 for general details.
- B. Shop Drawings:
 - 1. None Required
- C. Submit Manufacturer's Cut Sheets for the following:
 - 1. Any products not specifically listed in the PRODUCTS section shall require a submittal of the manufacturer's cut sheets and approval by the Cal Poly Designated Telecommunications Representative.
 - 2. Manufacturer specific cables connecting to testing equipment to ensure

proper refractive index.

- D. Submit a list of test equipment to be used along with most recent calibration information. Lastest calibration shall be no more than 12 months from data of testing.
- E. Prior to starting, a sample of test data shall be provided to the Cal Poly Designated Telecommunications Representative that is indicative of the reports that shall be submitted upon completion of project testing for approval.
- F. Provide the identity and qualifications of Contractor's personnel on the testing equipment who will perform the testing. Submit documentation for all test personnel verifying qualified operator training on the proposed test equipment.
- G. Submit a proposed schedule for performing testing at least 2 weeks prior to the start of each test.

1.5 IDENTIFICATION

- A. Refer to Section 27 05 53 for general details.

1.6 DEFINITIONS

- A. N/A

1.7 WARRANTY

- A. Refer to Section 27 00 00 for general

details. PART 2 - PRODUCTS

2.1 PRODUCT CONSISTENCY

- A. N/A

2.2 OPTICAL TIME DOMAIN REFLECTOMETER (OTDR)

- A. The personnel performing field testing shall provide results that meet the requirements of tests specified in ANSI/TIA/EIA-455, inclusive of all subsections.
- B. Make and model of test equipment requires approval of the Cal Poly Designated Telecommunications Representative. The Cal Poly ITS Telecomm Group currently has licensed copies of Agilent Technologies Traceviewer III and Fluke Linkware. If other manufacturer's test equipment is used the Contractor shall deliver to the Cal Poly Designated Telecommunications Representative a licensed copy of the necessary software to read and manipulate the test data as part of the contract. The software shall remain the property of the Cal Poly ITS Telecomm Group.
- C. Included in the test results submitted shall also be OTDR traces and power

loss sum information for each fiber optic core.

2.3 OPTICAL POWER MEASUREMENT EQUIPMENT

- A. Fluke Networks Linkware
 - 1. SimpliFiber
 - 2. OMNIScanner w/ Fiber Test Adapters or the Cal Poly Designated Telecommunications Representative approved equal.

2.4 OPTICAL FIBER INSPECTION SCOPE

- A. Fluke Networks
 - 1. Fiber Inspector Pro
 - 2. Other Inspection Scopes, if used, shall be approved in advance by the Cal Poly Designated Telecommunications Representative.

2.5 APPROVED MANUFACTURERS AND MATERIAL

- A. See Section 27 06 00 – Schedules for Communications for approved manufacturers and material to be supplied for this section.

PART 3- EXECUTION

3.1 GENERAL

- A. The Contractor shall test, as described below, all fiber optic cables installed under these specifications.
- B. Visually inspect all cables, cable reels, and shipping cartons to detect cable damage incurred during shipping and transport. Return visibly damaged items to the manufacturer.
- C. Where post-manufacturer test data has been provided by the manufacturer on the reel or shipping carton: submit copies to the Cal Poly Designated Telecommunications Representative prior to installing cables.
- D. Ensure Index of Refraction is set appropriate to the cable installed.
- E. Test fully completed systems only. Piecemeal testing is not acceptable.
- F. Testing shall not be performed until after all hardware is installed and attached, and all labeling and identification has been completed. Using any other methodology shall render the test data not acceptable.
- G. Any cable that does not pass all required testing shall be removed or replaced and retested.

- H. Remove and replace any defective cables from pathways system. Do not abandon cables in place.
- I. The Cal Poly Designated Telecommunications Representative reserves the right to observe all portions of the testing process.
- J. The Cal Poly Designated Telecommunications Representative further reserves the right to conduct "Proof of performance testing", using Contractor equipment and labor, by random re-testing of up to ten percent (10%) of the cable plant, to confirm documented test results. Multiple failures shall cause the percentage of the cable plant to be tested to increase.
- K. Perform all tests as required by the manufacturer in support of the structured cabling system warranty.

3.2 QUANTITIES

- A. N/A

3.3 INSTALLATION

- A. N/A

3.4 GROUNDING AND BONDING

- A. N/A

3.5 TESTING

- A. All test results shall be defined as acceptable / unacceptable by the requirements of ANSI/TIA/EIA-526, inclusive of all subsections.
- B. Fiber Optic Cables - General Requirements
 - 1. Index matching fluids or gels shall not be used.
 - 2. Strands whose measured attenuation fall outside the acceptable range shall be subject to further inspection and testing to determine the nature of the fault. Faults related to affixing the connector shall be corrected, and the fiber re-tested as described above, until acceptable attenuation measurements are recorded. If acceptable attenuation cannot be achieved, then the fiber shall be replaced in its entirety.
- C. Optical Time Domain Reflectometer Testing
 - 1. All OTDR testing procedures and field test instruments shall comply with applicable requirements of: EIA/TIA 455-78 and EIA/TIA 455-133.
 - 2. OTDR test jumpers must meet the criteria for reference jumpers specified in EIA/TIA-455-171.

3. A 1,000-foot launch cable shall be installed between the OTDR and the first link connection.
4. A 1,000-foot receive cable shall be installed after the last link connection.
5. All cables shall be OTDR tested at 1310 nm and 1550 nm for Single-mode operating wavelength anomalies and to ensure uniformity of cable attenuation and connector insertion loss.
6. All cables shall be OTDR tested at 850 nm and 1300 nm for Multi-mode operating wavelength anomalies and to ensure uniformity of cable attenuation and connector insertion loss.
7. All fiber links shall be tested in both directions.
8. Optical Return Loss (ORL) for each link shall be measured and documented.
9. Fiber Length shall be measured and documented.
10. Perform a high resolution OTDR test with tracing printouts noting each optical fiber and buffer tube color designation.

D. Optical Power Loss Testing

1. All fiber optic cables are to be tested via the One-Jumper Reference Method, formerly Method B.
2. Perform end-to-end, bi-directional attenuation (loss) test for each fiber strand at 850nm and 1300nm for multi-mode fiber or at 1310nm and 1550nm for single mode fiber.

E. Other Tests

1. After installation of connectors, visually inspect each fiber end-face at 200x magnification for multi-mode fiber and 400x magnification for single mode fiber. Replace fibers with visible defects and/or striations in the core area.

3.6 ACCEPTANCE

- A. All test results and corrective procedures shall be documented and submitted, in the manufacturer's approved software format, to the Cal Poly Designated Telecommunications Representative (with software and license if necessary) within five (5) working days of test completion. Test results submitted in the PDF format shall not be acceptable.
- B. Each test report shall contain the following general information:
 1. Date of Preparation
 2. Date of Test

3. Project Name (shall be: Start Building # / End Building #, with the same name used at both ends)
 4. Contractor's Name
 5. Media Type (MM / SM)
 6. Make, Model and Serial Number of test equipment used
 7. Date of Last Calibration
 8. Names of Test Crew.
- C. Submit the following information regarding the optical fiber cable testing:
1. Cable Number (Section 27 00 02 - APPENDIX B Labeling-Design-Syntax)
 2. Fiber Count
 3. Individual Fiber Numbers
 4. Connector Types
 5. Number of Connectors / Patches
 6. Calculated Maximum Link Loss
 7. Length of Run
 8. Results of Each Test for Each Fiber
 9. Measured Link Loss for Each Fiber.
- D. Test result shall be recorded per cable and identical copies placed on USB drives (or other mutually acceptable media and format) for delivery to the Cal Poly Designated Telecommunications Representative (along with software and license if necessary). The PDF format shall be unacceptable. (Software will not be returned)
- E. Once the testing has been completed and the Cal Poly Designated Telecommunications Representative is satisfied that all work is in accordance with the Contract Documents, the representative will notify the Contractor and/or the Cal Poly Facilities Project Manager in writing or via email.
- 3.7 RECORD (AS-BUILT) DRAWINGS
- A. None

Required END OF SECTION

SECTION 27 11 00 – COMMUNICATIONS EQUIPMENT ROOM FITTINGS

PART 1 - GENERAL

1.1 DESCRIPTION

- A. The work covered by this section of the Specifications includes all labor necessary to perform and complete such construction, all materials and equipment incorporated or to be incorporated in such construction and all services, facilities, tools and equipment necessary or used to perform a complete installation of the Telecommunications Systems and Components. The work of this section shall include, but is not limited to, the following:
 - 1. Basic telecommunications room (MDF/IDF/SDF) requirements in accordance with relevant codes and best industry practices.

1.2 QUALITY ASSURANCE

- A. Refer to Section 27 00 00 for general details.

1.3 CODES, STANDARDS, AND GUIDELINES

- A. Except as modified by governing codes and by the Contract Documents, comply with the applicable provisions and recommendations in Section 27 00 00.
- B. The University Telecommunication Infrastructure Planning (UTIP) Standards document and Section 27 00 02 - APPENDIX B Labeling-Design-Syntax.

1.4 SUBMITTALS

- A. Refer to Section 27 00 00 for general details.
- B. Shop Drawings:
 - 1. None Required
- C. Submit Manufacturer's Cut Sheets for the following:
 - 1. Any products not specifically listed in the PRODUCTS section shall require a submittal of the manufacturer's cut sheets and approval by the Cal Poly Designated Telecommunications Representative.

1.5 IDENTIFICATION

- A. All electrical outlets/faceplates are to be labeled as to Panel and Circuit ID.

- B. Refer to Section 27 05 53 for general details.
- C. Refer to Section 27 00 02 - APPENDIX B Labeling-Design-Syntax

1.6 DEFINITIONS

- A. N/A

1.7 WARRANTY

- A. Refer to Section 27 00 00 for general details.

PART 2 - PRODUCTS

2.1 PRODUCT CONSISTENCY

- A. Product Consistency: Any given item of equipment or material shall be the product of one manufacturer throughout the facility. Multiple manufacturers of any one item shall not be permitted.

2.2 APPROVED MANUFACTURERS AND MATERIAL

- A. See Section 27 06 00 – Schedules for Communications for approved manufacturers and material to be supplied for this section.

2.3 PLYWOOD BACKBOARD

- A. Shall be 4' x 8' x 3/4" A/C, fire rated plywood with appropriate stamp affixed. The stamp is to remain visible at all times. (See Fig. #146 in Section 27 00 02 - APPENDIX B Labeling-Design-Syntax)
- B. Shall be painted with white (light colored), acrylic, interior, fire-retardant paint on all sides and edges.

2.4 DUCT SEAL (CONDUITS POPULATED WITH CABLING)

- A. Shall be used only where a fire rated assembly is not required.
- B. Shall be of Asbestos Free, easily formable clay. (See Fig. #136 in Section 27 00 02 - APPENDIX B Labeling-Design-Syntax)
- C. Shall not dry hard and shall be re-enterable/reusable.
- D. Shall be resistant to water, alcohols, solvents & fuels.
- E. Shall be non-corrosive to metals or plastics and a non-irritant to skin.

2.5 DUCT SEAL (UNPOPULATED CONDUITS)

- A. Shall be used only where a fire rated assembly is not required.
- B. Shall be removable and reusable compression type fitting/plug. (See Fig. #137 in Section 27 00 02 - APPENDIX B Labeling-Design-Syntax)

- C. Shall be corrosion proof, water-tight and gas-tight.
- D. Shall be equipped with a rear side pull rope

tiedown. PART 3- EXECUTION

3.1 GENERAL

- A. Refer, as appropriate, to other Division 27 specifications for specific execution instructions.

3.2 QUANTITIES

- A. Quantities of system elements shown on the drawings are illustrative only and are meant to indicate the general configuration of the work. The Contractor shall be responsible for providing the correct quantities of materials to construct a system that meets the intent of these Specifications and the relevant codes.

3.3 INSTALLATION

- A. Follow manufacturer's complete instructions for installation and configuration of all products used.

3.4 GROUNDING AND BONDING

- A. All MDFs shall be provided with a labeled Primary Bonding Busbar (PBB). (See Fig. #140 & 164 in Section 27 00 02 - APPENDIX B Labeling-Design-Syntax)
- B. All IDFs and SDFs shall be provided with a labeled Secondary Bonding Busbar (SBB). (See Fig. #140 & 164 in Section 27 00 02 - APPENDIX B Labeling-Design-Syntax)
- C. All equipment, racks, metal conduit, cable tray and cable shields shall be properly bonded to the PBB or SBB as appropriate.
- D. The electrical panel serving an MDF, IDF, or SDF shall be grounded to that facility's PBB.
- E. All metallic conduits entering or exiting the MDF, IDF, or SDF shall be bonded to the PBB or SBB with a minimum #6AWG copper wire.
- F. Refer to Section 27 05 26 for additional details.

3.5 TESTING

- A. Devices shall be tested as part of the required system testing for the cabling they support.

3.6 ACCEPTANCE

- A. Once the testing has been completed and the Cal Poly Designated

Telecommunications Representative is satisfied that all work is in accordance with the Contract Documents, the representative will notify the Contractor and/or the Cal Poly Facilities Project Manager in writing or via email.

3.7 RECORD (AS-BUILT) DRAWINGS

A. None

Required END OF SECTION

SECTION 27 11 13 – COMMUNICATIONS ENTRANCE PROTECTION

PART 1 - GENERAL

1.1 DESCRIPTION

- A. The work covered by this section of the Specifications includes all labor necessary to perform and complete such construction, all materials and equipment incorporated or to be incorporated in such construction and all services, facilities, tools and equipment necessary or used to perform a complete installation of the Telecommunications Systems and Components. The work of this section shall include, but is not limited to, the following:

- 1. Building entrance protectors and related accessories

1.2 QUALITY ASSURANCE

- A. Refer to Section 27 00 00 for general details.

1.3 CODES, STANDARDS, AND GUIDELINES

- A. Except as modified by governing codes and by the Contract Documents, comply with the applicable provisions and recommendations in Section 27 00 00.
- B. Customer Owned Outside Plant Design Manual (BICSI)
- C. Telcordia GR-974, Issue 3
- D. The University Telecommunication Infrastructure Planning (UTIP) Standards document and Section 27 00 02 - APPENDIX B Labeling-Design-Syntax.

1.4 SUBMITTALS

- A. Refer to Section 27 00 00 for general details.
- B. Shop Drawings:
 - 1. Shop drawings shall show the locations of protector blocks and splices, pair counts and cable designations at each installed entrance protector.
- C. Submit Manufacturer's Cut Sheets for the following:
 - 1. Any products not specifically listed in the PRODUCTS section shall require a submittal of the manufacturer's cut sheets and approval by the Cal Poly Designated Telecommunications Representative.

1.5 IDENTIFICATION

- A. Identify each protector unit as to the details of the cable (other end of the cable, wire path, number of pairs, etc.) See Section 27 00 02 - APPENDIX B Labeling-Design- Syntax.
- B. Outdoor cables shall be labeled with outdoor rated, 1" wide, white with machine generated black lettering (DYMO type label) at each endpoint and entering and exiting each underground facility.
- C. Refer to Section 27 05 53 for additional details.

1.6 DEFINITIONS

- A. N/A

1.7 WARRANTY

- A. Refer to Section 27 00 00 for general

details. PART 2 - PRODUCTS

2.1 PRODUCT CONSISTENCY

- A. Product Consistency: Any given item of equipment or material shall be the product of one manufacturer throughout the facility. Multiple manufacturers of any one item shall not be permitted.

2.2 APPROVED MANUFACTURERS AND MATERIAL

- A. See Section 27 06 00 – Schedules for Communications for approved manufacturers and material to be supplied for this section.

2.3 BUILDING ENTRANCE TERMINAL

- A. Shall be used with entrance cabling that terminates in an MDF.
- B. The units shall be 100 pair with input stub cable and 66 block style output.
- C. Terminal unit to incorporate a 26 AWG fuse link cable stub for 710 splicing to OSP cable.
- D. Refer to section 27-06-00 for fuse type.
- E. Must be UL listed. (See Fig. #142 in Section 27 00 02 - APPENDIX B Labeling-Design- Syntax)

2.4 SURGE PROTECTION MODULE

- A. Protectors shall utilize heat coils.
- B. Balanced 3-element gas discharge tube with fail-safe.

- C. Gas discharge tube is without backup gap.
 - D. Built in Fail-safe device.
 - E. Self-resetting sneak current protection (PTCs).
 - F. Low capacitance (less than 10 pF) and low resistance (2.2 ohm PTCs).
 - G. Protectors shall incorporate gold plated connections.
- 2.5 ENTRANCE PROTECTOR FOR HORIZONTAL COPPER UTP OSP STATION CABLE (VOICE)
- A. Six Pair, Cat3 with 110 IDC termination input and output
 - B. UL 497 Listed for primary protection
 - C. Refer to section 27-06-00 for fuse type.
- 2.6 ENTRANCE PROTECTOR FOR HORIZONTAL COPPER UTP OSP STATION CABLE (DATA)
- A. Four Pair, CAT 6 with 110 IDC termination input and output
 - B. Supports 1 Gigabit & POE where Power and Data are on all 4-Pairs
- 2.7 SPLICE CASE
- A. Splice case for terminating entrance OSP cable to Protector Panel stub cable
 - B. All splices in a splice case shall be terminated with 3M 710 style connectors.
 - C. Sized as required for pair counts and cable size.
 - D. Shall be fire retardant, and re-enterable.
 - E. End caps shall be sized as required for the number and size of the cables.
 - F. All splices, splice cases, and connectors shall be installed per manufacturers written instructions.
 - G. Connect sheath to grounding bar (PBB) to provide cable sheath

continuity. PART 3- EXECUTION

3.1 GENERAL

- A. Location and placement of termination blocks, splice closures, splices and other related hardware shall be as shown on the drawings or defined in the Cable Schedules.
- B. Final placement of termination blocks, splice cases, splices, OSP cable (routing) and other related hardware shall be approved in advance by the Cal Poly Designated Telecommunications Representative.
- C. For each OSP cable that extends beyond the drip line of the building, an appropriately sized entrance protector module shall be provided at both ends.

3.2 QUANTITIES

- A. Quantities of blocks, splice closures, splices, etc. shown on the drawings are illustrative only and are meant to indicate the general configuration of the work. The Contractor is responsible for providing the correct quantities of blocks, connectors, etc. necessary to terminate, cross-connect and patch the volume of cable described herein and shown on the drawings.

3.3 INSTALLATION

- A. Building Entrance Terminals
 1. Submit Shop Drawings to the Cal Poly Designated Telecommunications Representative for approval of block field, protector and splice case layouts and locations as well as OSP cable routing before starting work.
 2. Building Entrance Terminals shall only be installed within MDF rooms unless previously approved by the Cal Poly Designated Telecommunications Representative.
 3. Per NEC 800-90, Building Entrance Terminals shall be located as close as practical to its cable's point of entrance to a building.
 4. Cables from different buildings shall not to share the same building entrance terminals.
 5. All building entrance terminals shall be fully populated with surge protection modules of the same make, model and manufacturer regardless of conductor count.
 6. Each protector shall be individually grounded to the PBB or ground rod with a #6 AWG copper bonding conductor. (not daisy-chained)
 7. All building entrance terminals shall be labeled. (See Fig. #101 & 106 in in Section 27 00 02 - APPENDIX B Labeling-Design-Syntax).
- B. Entrance Protectors for OSP CAT 3 Station Cable
 1. Entrance Protectors for OSP Station Cable shall only be installed within MDF telecommunications spaces.
 2. Each cable shall terminate on its own entrance protector.
 3. All entrance protectors shall be fully populated with surge protection modules of the same make, model and manufacturer.
 4. Each protector shall be individually grounded to the PBB or ground rod with a #6 AWG copper bonding conductor. (not daisy-chained)

5. All entrance protectors shall be labeled. See Section 27 05 53 and the in Section 27 00 02 - APPENDIX B Labeling-Design-Syntax for more detail. (See Fig. #101 & 106 in in Section 27 00 02 - APPENDIX B Labeling-Design-Syntax)

C. Splice Cases

1. Splice cases shall only be employed within a building and shall not be placed in a vault or other underground structure.
2. OSP cables from separate buildings shall not share the same splice case.
3. Each splice shall be individually grounded to the PBB with a #6 AWG copper bonding conductor. (not daisy-chained)

3.4 GROUNDING AND BONDING

- A. Each protector shall be individually grounded to the PBB or ground rod with a #6 AWG copper bonding conductor. (not daisy-chained)
- B. Each splice case shall be individually grounded to the PBB with a #6 AWG copper bonding conductor.
- C. Refer to Section 27 05 26 for additional details.

3.5 TESTING

- A. Devices shall be tested as part of the required system testing for the cabling they protect and serve.

3.6 ACCEPTANCE

- A. Once the testing has been completed and the Cal Poly Designated Telecommunications Representative is satisfied that all work is in accordance with the Contract Documents, the representative will notify the Contractor and/or the Cal Poly Facilities Project Manager in writing or via email.

3.7 RECORD (AS-BUILT) DRAWINGS

- A. The Project Record Drawings shall show the types and locations of all entrance protectors. Drawings shall include identifying information from the cable identification labels.

END OF SECTION

SECTION 27 11 16 – COMMUNICATIONS CABINETS, RACKS, FRAMES, AND ENCLOSURES

PART 1 - GENERAL

1.1 DESCRIPTION

- A. The work covered by this section of the Specifications includes all labor necessary to perform and complete such construction, all materials and equipment incorporated or to be incorporated in such construction and all services, facilities, tools and equipment necessary or used to perform a complete installation of the Telecommunications Systems and Components.
 - 1. Fixed 2 Post 19" x 7' equipment racks complete with all necessary installation hardware.
 - 2. Fixed 19" equipment cabinets complete with all necessary installation hardware.

1.2 QUALITY ASSURANCE

- A. Refer to Section 27 00 00 for general details.

1.3 CODES, STANDARDS, AND GUIDELINES

- A. Except as modified by governing codes and by the Contract Documents, comply with the applicable provisions and recommendations in Section 27 00 00.
- B. ANSI/EIA-310-D (Racks, Panels, and Associated Equipment).
- C. NEBS-Telcordia GR-63-CORE Zone 4
 - 1. Tested with 500 lbs. of equipment installed and 100 lbs. of simulated cable weight on the top.
- D. The University Telecommunication Infrastructure Planning (UTIP) Standards document and Section 27 00 02 - APPENDIX B Labeling-Design-Syntax.

1.4 SUBMITTALS

- A. Refer to Section 27 00 00 for general details.
- B. Shop Drawings:
 - 1. Shop drawings shall show the position of the equipment racks in the MDF/IDF/SDF. Racks shall be dimensioned, and the position of the rack or cabinet shall be dimensioned from (2) walls in each MDF/IDF/SDF. All

2. MDF/IDF/SDF equipment rack layouts shall be reviewed and approved by the Cal Poly Designated Telecommunications Representative prior to the ordering and/or installation of any product.
 3. Shop drawings for equipment racks shall also show the method of attachment to the floor and to any overhead ladder rack. All cable management raceways for equipment racks shall be shown in the shop drawings.
- C. Submit Manufacturer's Cut Sheets for the following:
1. Any products not specifically listed in the PRODUCTS section shall require a submittal of the manufacturer's cut sheets and approval by the Cal Poly Designated Telecommunications Representative.

1.5 IDENTIFICATION

- A. Each rack shall require a ½" white, permanent, polyester label with black ink denoting the rack designation.
- B. Refer to Section 27-05-53 for additional details.
- C. Refer to Section 27 00 02 - APPENDIX B Labeling-Design-Syntax.

1.6 DEFINITIONS

- A. N/A

1.7 WARRANTY

- A. Refer to Section 27 00 00 for general

details. PART 2 - PRODUCTS

2.1 PRODUCT CONSISTENCY

- A. Any given item of equipment or material shall be the product of one manufacturer throughout the facility. Multiple manufacturers of any one item will not be permitted.

2.2 APPROVED MANUFACTURERS AND MATERIAL

- A. See Section 27 06 00 – Schedules for Communications for approved manufacturers and material to be supplied for this section.

2.3 EQUIPMENT RACKS SHALL BE AS FOLLOWS:

- A. Racks shall be manufactured from aluminum extrusions.
- B. Each rack shall have two L-shaped top angles, two L-shaped base angles and two C- shaped equipment mounting channels. The rack shall assemble with

bolt hardware. Equipment-mounting channels shall be threaded for easy assembly. The base angles shall be 3.88" x 6.0" x .375" thick and will be pre-punched for attachment to the floor.

- C. Equipment mounting channels shall be 3" deep x 1.265" wide x .25" thick and punched on the front and rear flange with the EIA-310-D Universal hole pattern.
- D. When assembled with top and bottom angles, equipment-mounting channels shall be spaced to allow attachment of 19" EIA rack-mount equipment. Attachment points shall be threaded with 12-24 roll-formed threads. The rack will include assembly and equipment-mounting hardware. Each rack shall include 50 each combination Phillips type, pan head, pilot point mounting screws.
- E. Top angle shall be 1.25" x 1.25" x .25" thick.
- F. The assembled rack shall measure 7' (84") high, 20.32" wide, and 15" deep. The sides of the equipment mounting channels shall have threaded mounting points to allow attachment of vertical cable managers along the sides of the rack.
- G. The rack shall be rated for 1,000 lb. of equipment (minimum).
- H. The rack shall be UL Listed.
- I. Finish shall be (bare aluminum) silver/gray in color.

2.4 VERTICAL RACK MOUNT WIRE MANAGEMENT SHALL BE AS FOLLOWS:

- A. Vertical Wire Manager
 - 1. A combination, double-sided vertical cable manager
 - 2. Front accessible side shall employ T-shaped cable fingers with rounded edges and include a contoured front door with easy-open knobs.
 - 3. Rear accessible side shall consist of adjustable rear cable rings with spin open latches.
 - 4. Cable openings shall align with each rack-mount unit on the specified rack and pass 48 patch cords.
 - 5. Color is to be black.

2.5 HORIZONTAL RACK MOUNT WIRE MANAGEMENT SHALL BE AS FOLLOWS:

- A. Fiber/Copper Jumper Crossover Trough
 - 1. Double-sided, 4RU, 19" EIA rack mount horizontal jumper trough for patch cables. One Trough shall be installed at the top of every 19" rack cabinet.
 - 2. Radiused drop offs on each end of the tray.

3. Color is to be black.

B. Copper Cable Wire Manager

1. Provide single-sided, 2RU, 19" EIA rack mount, horizontal Cable Managers as required. One shall be installed in the 2U just under the Jumper Cross-over Trough and one additional cable manager under every station patch panel.
2. Provides a side-to-side pathway that aligns with specified vertical managers.
3. Color is to be black.

2.6 WALL MOUNTED EQUIPMENT RACKS AND CABINETS (REQUIRES PRIOR ITS TELECOMM APPROVAL)

- A. In new construction projects wall mounted equipment racks and cabinets shall not be used. All telecommunications related resource requirements shall be provided by and from an established MDF/IDF/SDF.
- B. When the remodeling of existing structures is required, a MDF/IDF/SDF shall be constructed/established to exclusively house all telecommunications related equipment. In cases where the Cal Poly Designated Telecommunications Representative agrees that it is not possible to create a separate MDF/IDF/SDF, the use of wall mounted and/or enclosed and lockable rack infrastructure may need to be considered. If so, such installations shall only be constructed using Cal Poly Designated Telecommunications Representative reviewed and approved drawings and/or specifications. Final acceptance of the approved installation shall be the sole responsibility of the Cal Poly Designated Telecommunications Representative.

PART 3- EXECUTION

3.1 GENERAL

- A. Location and placement of equipment racks shall be as shown on the Drawings, defined in the specifications and schedules and preapproved by the Cal Poly Designated Telecommunications Representative.
- B. Usage
 1. 2 Post racks are the only rack type that shall be used within designated MDF/IDF/SDF locations.
 2. Two post racks shall be used in all other secured, dedicated, locked, and environmentally controlled areas.
 3. Enclosed and lockable cabinets shall be used in environmentally

controlled but public areas.

- C. Equipment racks and cabinets shall be assembled and installed as per the manufacturers' printed instruction and meet all Seismic Zone 4 requirements.
- D. Any excess length of bolts or threaded rods shall be trimmed to no more than ½" past the nut and de-burred. Preferred style of attachment is "drop-in" style threaded inserts if allowed.
- E. Project designs requiring enclosed and/or lockable cabinets shall be submitted to the Cal Poly Designated Telecommunications Representative for review and approval prior to the purchase and/or installation of material.

3.2 QUANTITIES

- A. Quantities and sizes of rack equipment and components shown on the Drawings are illustrative only and are meant to indicate the general configuration of the work. The Contractor is responsible for providing the correct quantities of all materials necessary to accommodate the equipment and to terminate, cross connect and patch the volume of cable described in these specifications and schedules and shown on the Drawings.
- B. Quantities of Wire Managers
- C. Vertical Wire Managers
 - 1. Rooms with 2 racks will have two 6" and one 12" vertical wire managers.
 - 2. Rooms with 3 racks will have two 6" and two 12" vertical wire managers.
 - 3. Rooms with 4 racks will have two 6" and three 12" vertical wire managers.
 - 4. Rooms with 5 racks will have two 6" and four 12" vertical wire managers.
- D. Horizontal Wire Managers
 - 1. Each 2-post rack shall include a minimum of two, 2RU Horizontal wire managers and one Fiber Radiused Cross-over Trough installed at the top.
 - 2. Wall cabinet or wall rack installations shall use 1RU wire management in such quantities as required by the Cal Poly Designated Telecommunications Representative.

3.3 INSTALLATION

- A. Follow manufacturer's installation instructions for compliance with referenced Seismic Zone 4 requirements.

- B. If any part of the project requires equipment racks to be installed in a raised floor application or requires auxiliary supports for which no Manufacturer's installation details are available allowing for compliance with the referenced seismic standards, the Contractor must provide an alternate installation approved by a structural engineer.
- C. Equipment racks and wall cabinets must be mounted and approved by the AHJ, as to appropriateness for anticipated equipment loads. Any proposed reinforcement shall be the responsibility of the Contractor.
- D. Wall cabinets and wall racks shall be mounted such that there are no obstructions or impediments to the full opening radius of the enclosure.
- E. Wall cabinets and wall racks shall be mounted such that they do not obstruct access to any other junctions, pull boxes, control panels, cabinets, etc.

3.4 GROUNDING AND BONDING

- A. All racks and cabinets shall be individually grounded to the PBB or SBB with a #6 AWG copper bonding conductor.
- B. Refer to Section 27 05 26 for additional details.

3.5 TESTING

- A. None required unless specified by AHJ or other contract requirements.

3.6 ACCEPTANCE

- A. Once the testing has been completed and the Cal Poly Designated Telecommunications Representative is satisfied that all work is in accordance with the Contract Documents, the representative will notify the Contractor and/or the Cal Poly Facilities Project Manager in writing or via email.

3.7 RECORD (AS-BUILT) DRAWINGS

- A. The Project Record Drawings shall show the types and locations of installed equipment racks and (if allowed by the Cal Poly Designated Telecommunications Representative) wall cabinets.

END OF SECTION

SECTION 27 11 19 – COMMUNICATION TERMINATION BLOCKS AND PATCH PANELS

PART 1 - GENERAL

1.1 DESCRIPTION

- A. The work covered by this section of the Specifications includes all labor necessary to perform and complete such construction, all materials and equipment incorporated or to be incorporated in such construction and all services, facilities, tools and equipment necessary or used to perform a complete installation of the Telecommunications Systems and Components.
 - 1. MDF, IDF, or SDF station cable termination system complete with all necessary installation hardware and labeling.
 - 2. Wall mounted termination systems shall not be allowed unless approved by the Cal Poly Designated Telecommunications Representative.

1.2 QUALITY ASSURANCE

- A. Refer to Section 27 00 00 for general details.
- B. As noted in Section 27-00-00, all contractors and installers working on structured cabling system elements must hold a current manufacturer's certification for each individual component they install.

1.3 CODES, STANDARDS, AND GUIDELINES

- A. Except as modified by governing codes and by the Contract Documents, comply with the applicable provisions and recommendations in Section 27 00 00.
- B. The University Telecommunication Infrastructure Planning (UTIP) Standards document and Section 27 00 02 - APPENDIX B Labeling-Design-Syntax.

1.4 SUBMITTALS

- A. Refer to Section 27 00 00 for general details.
- B. Shop Drawings:
 - 1. Shop drawings shall show the locations of all termination blocks and the location of each end of every cable that shall be terminated on them.
- C. Submit Manufacturer's Cut Sheets for the following:

1. Any products not specifically listed in the PRODUCTS section shall require a submittal of the manufacturer's cut sheets and approval by the Cal Poly Designated Telecommunications Representative.

1.5 IDENTIFICATION

- A. Termination blocks shall be labeled as shown in Section 27 00 02 - APPENDIX B Labeling-Design-Syntax.
- B. Details for terminal block labeling shall be reviewed and approved by the Cal Poly Designated Telecommunications Representative. (See Fig. #121 & 122 in Section 27 00 02 - APPENDIX B Labeling-Design-Syntax)
- C. Patch panels shall be labeled with ½" white permanent polyester with black labeling. (See Fig. #104, 105 & 147 in Section 27 00 02 - APPENDIX B Labeling-Design-Syntax)
- D. Refer to Section 27-05-53 for additional details.

1.6 DEFINITIONS

- A. All patch panels shall be 48 Port. No other size is acceptable.

1.7 WARRANTY

- A. Refer to Section 27 00 00 for general

details. PART 2 - PRODUCTS

2.1 PRODUCT CONSISTENCY

- A. Product Consistency: Any given item of equipment or material shall be the product of one manufacturer throughout the facility. Multiple manufacturers of any one item will not be permitted.

2.2 RACK MOUNT PATCH PANELS

- A. Shall be rack mountable in standard, 2 post 19" equipment rack. (See Fig. #104 & 145 in Section 27 00 02 - APPENDIX B Labeling-Design-Syntax)
- B. Shall meet or exceed ANSI/TIA- 568-C.2 Category 6A specifications.
- C. Shall be provided in 48-port configuration (only) featuring universal A/B labeling. (See Fig. #104 & 105 in Section 27 00 02 - APPENDIX B Labeling-Design-Syntax)
- D. Use 110 connector terminations on rear of panel allowing installation of 22 to 24 AWG cable.
- E. Shall be black powder covered high-strength aluminum panel with a

- F. removable rear mounted cable management bar.
- G. Shall include preprinted jack position numbers on the front panel and customizable cable ID labels above each position.
- H. Shall be backward compatible with Category 5e and 5 patch cords and cables.

2.3 APPROVED MANUFACTURERS AND MATERIAL

- A. See Section 27 06 00 – Schedules for Communications for approved manufacturers and material to be supplied for this section.

PART 3- EXECUTION

3.1 GENERAL

- A. Location and placement of wall- field shall be as shown on the Drawings or defined in these specifications and schedules.
- B. Supplied termination hardware shall accommodate 30% growth in cable terminations per floor.
- C. Termination hardware and patch panels shall be assembled and installed as per the manufacturers' printed instructions.
- D. Do not install termination blocks until after their installation location has been approved by the Cal Poly Designated Telecommunications Representative.

3.2 QUANTITIES

- A. Quantities of wall field and components, patch panels, etc. shown on the Drawings are illustrative only and are meant to indicate the general configuration of the work. The Contractor shall be responsible for providing the correct quantities of blocks, connectors, etc. necessary to terminate, cross-connect and patch the volume of cable described herein and shown in the Drawings.

3.3 INSTALLATION

- A. Installation Pattern
 - 1. A minimum installation pattern shall be composed of one 4U rack mountable patch panel with 48 ports. Patch panels with other than 48 ports shall not be acceptable.
 - 2. For additional station cables, add a second patch panel below the first. Include all required vertical and horizontal wire management. Increase the number of patch panels as necessary to a maximum of six per rack (192 cables).
 - 3. For additional station cables beyond 192, expand to a second equipment

rack adding panels from the top down with a maximum of six 48 port patch panels (192 cables) and so on as necessary. Vertical and horizontal wire management shall be provided as required. (See Fig. #148 in Section 27 00 02 - APPENDIX B Labeling- Design-Syntax)

4. Sufficient patch panel space shall be provided to allow for a 30% growth in cable terminations per floor.
5. See Section 27 00 02 - APPENDIX B Labeling-Design-Syntax.

3.4 GROUNDING AND BONDING

- A. All wall patch panels shall be individually grounded to the TGB/TMGB with a #6 AWG copper bonding conductor.
- B. Refer to Section 27-05-26 for additional details.

3.5 TESTING

- A. Devices shall be tested as part of the required system testing for the cabling they support.

3.6 ACCEPTANCE

- A. Any deviation from the provided drawings or Section 27 00 02 - APPENDIX B Labeling- Design-Syntax shall require submission and approval of a revised shop drawing by the Cal Poly Designated Telecommunications Representative before the installation begins.
- B. Once the testing has been completed and the Cal Poly Designated Telecommunications Representative is satisfied that all work is in accordance with the Contract Documents, the representative will notify the Contractor and/or the Cal Poly Facilities Project Manager in writing or via email.

3.7 RECORD (AS-BUILT) DRAWINGS

- A. Show the types and locations of installed cable termination hardware on project Drawings.

END OF SECTION

SECTION 27 11 20 – COMMUNICATIONS FIBER CABINETS, ADAPTERS, AND CONNECTORS

PART 1 - GENERAL

1.1 DESCRIPTION

- A. The work covered by this section of the Specifications includes all labor necessary to perform and complete such construction, all materials and equipment incorporated or to be incorporated in such construction and all services, facilities, tools and equipment necessary or used to perform a complete installation of the Telecommunications Systems and Components.
 - 1. MDF/ISD/SDF fiber optic termination system complete with all necessary installation hardware.

1.2 QUALITY ASSURANCE

- A. Refer to Section 27 00 00 for general details.
- B. As noted in Section 27 00 00, all contractors and installers working on structured cabling system elements shall hold a current manufacturer's certification for each individual component they install.

1.3 CODES, STANDARDS, AND GUIDELINES

- A. Except as modified by governing codes and by the Contract Documents, comply with the applicable provisions and recommendations in Section 27 00 00.
- B. ANSI/TIA-568-C.3
- C. The University Telecommunication Infrastructure Planning (UTIP) Standards document and Section 27 00 02 - APPENDIX B Labeling-Design-Syntax.

1.4 SUBMITTALS

- A. Refer to Section 27 00 00 for general details.
- B. Shop Drawings:
 - 1. Shop drawings shall show the locations of fiber optic terminations and the end points of each cable.
- C. Submit Manufacturer's Cut Sheets for the following:
 - 1. Any products not specifically listed in the PRODUCTS section shall require a

submittal of the manufacturer's cut sheets and approval by the Cal Poly Designated Telecommunications Representative.

1.5 IDENTIFICATION

- A. Fiber Cabinets shall be labeled with ½" white permanent polyester with black labeling. Detail shall be provided as shown in Section 27 00 02 - APPENDIX B Labeling-Design- Syntax.
- B. Refer to Section 27 05 53 for additional details.

1.6 DEFINITIONS

- A. N/A

1.7 WARRANTY

- A. Refer to Section 27 00 00 for general

details. PART 2 - PRODUCTS

2.1 PRODUCT CONSISTENCY

- A. Any given item of equipment or material shall be the product of one manufacturer throughout the facility. Multiple manufacturers of any one item will not be permitted.

2.2 APPROVED MANUFACTURERS AND MATERIAL

- A. See Section 27 06 00 – Schedules for Communications for approved manufacturers and material to be supplied for this section.

2.3 FIBER OPTIC TERMINATION CABINET (RACK MOUNT) SHALL:

- A. Be constructed of 16 gauge steel with black powder coat finish.
- B. Be fully enclosed 19" rack mountable cable management type patch cabinets.
- C. Have a Plexiglas locking front panel. Labeling and connectors shall be clearly visible with front panel open or closed.
- D. Have a lockable, removable rear access panel.
- E. Be modular and accept a variety of inter-changeable bulkheads as well as attenuators, capable of holding "ST", "SC" and "LC" barrel connectors.
- F. Have an integrated front cable management trough.
- G. Employ trays and modules that provide a means to avoid exceeding the cable manufacturer's minimum bending radius to protect against crimping or over bending.
- H. Provide full rubber grommets for dust protection at all cable entry and exit points.

- I. Provide accommodation for labels identifying optical fiber splices and terminations.
- 2.4 FIBER OPTIC TERMINATION CABINET FOR HARSH ENVIRONMENTS SHALL: (WALL MOUNT-REMODEL ONLY)
- A. Constructed of 16 gauge steel with black powder coat finish.
 - B. Accommodate snap-in adapter plates and cassette modules.
 - C. Provide removable, a lockable hinged door.
 - D. Provide two-tier fiber storage hoops for fiber management.
 - E. Provide top and bottom accesses have cable tie-downs/strain relief and full grommets.
 - F. Provide lockable inner door that is removable.
 - G. Meet NEMA 12 rated requirements.
- 2.5 FIBER OPTIC TERMINATION CABINET FOR SPACE CONSTRAINED TERMINATION SHALL:
- A. Be constructed of 16 gauge steel with white or black powder coat finish.
 - B. Accommodate snap-in bulkhead adapter plates.
 - C. Include a lockable hinged door.
 - D. Provide top and bottom access, have a cable tie-down/strain relief and full grommets.
- 2.6 BULKHEADS - BARREL CONNECTORS SHALL:
- A. Barrel connectors shall have ceramic alignment sleeves for single-mode.
 - B. Bulkheads shall be removable from the front of the cabinet and shall be of a tool-less design.
 - C. Barrel connectors shall provide dust caps for every connector.
 - D. Barrel connectors shall be type LC as defined in ANSI/TIA/EIA-568. E. Max insertion loss across mated pair shall be less than .5db.
- 2.7 CONNECTORS (RISER/TIE/OSP/STATION FIBER OPTIC CABLE)
- A. Factory applied connectors on pigtails shall be available in 12 colors and shall be 6 feet in length each.
 - B. All pigtails shall be fusion-spliced.
 - C. Shall have a maximum insertion loss across mated pair: less than .5db.
 - D. Shall consist of optical Fiber: Single Mode: Color shall be Blue
- 2.8 FIBER FUSION SPLICE CASE W/ SPLICE TRAYS (OSP TO RISER FIBER)
- A. Shall require no special tools.

- B. Shall be re-enterable mechanical cable and O-ring equipped closure sealing system.
- C. Shall provide multiple, expandable, split grommets, and wide opening cable ports.
- D. Shall accept a range of cable

sizes. PART 3- EXECUTION

3.1 GENERAL

- A. The Contractor shall place all optical fiber backbone cabling in accordance with these specifications, and as indicated on the cable schedules and the Drawings.
- B. Rack mounted cabinets shall be used in MDF/IDF/SDF locations. Wall mounted cabinets shall be used outside of MDF/IDF/SDF locations if design is approved by the Cal Poly Designated Telecommunications Representative.
- C. Provide 50' slack loops at the MDF end of all OSP cables over 12 strands, and 20' slack loops at the MDF end of all other cables.
- D. Provide 72" of stripped fiber wrapped neatly at each fiber cabinet.
- E. Provide 72" of stripped fiber at the outlet end of any station fiber.
- F. All fiber terminations are to utilize color coded (blue for LC single mode connectors unless otherwise noted).
- G. Termination of fiber optic cables for use by the Fire Alarm System shall not to be terminated in an MDF/IDF/SDF. Termination of fiber for the FACP end of Fire Alarm System cable shall be done directly in the fire alarm panel or other non-telecomm space location if directed by the AHJ.
- H. No patch cables shall be installed until after the fiber optic test reports have been reviewed and accepted by the Cal Poly Designated Telecommunications Representative.

3.2 QUANTITIES

- A. Quantities of system elements shown on the drawings are illustrative only and are meant to indicate the general configuration of the work. The Contractor is responsible for providing the correct quantities of materials to construct a system that meets the intent of these Specifications and the relevant codes.

3.3 INSTALLATION

- A. Cabinets
 - 1. Rack location details (including elevation) for fiber cabinet mounting shall be approved by the Cal Poly Designated Telecommunications

Representative prior to installation.

2. After dressing the cable to its final destination, the sheath shall be removed to a point that allows the optical fiber strands to be splayed and terminated in a neat and uniform fashion.
3. All fiber cabinets shall employ factory provided, appropriately sized grommets for all openings.
4. All unused bulkhead openings shall be filled with blank plates.

B. Connectors

1. Terminations of fiber pigtails shall be by fusion splices only. Fibers will be terminated in strict compliance with the manufacturer's printed instructions.
2. Maximum length differential between terminated strands per bundle shall be 6". If the length does not meet this requirement the entire bundle must be re-terminated.

C. Gel Filled Cables

1. All gel filled cables will require use of a gel blocking sealant at any point that the gel is exposed.
2. Follow all manufacturers' specifications for proper application of gel block sealant.

D. Fiber Optic Splices

1. In general, optical fiber cables shall not to be spliced unless otherwise noted.
2. Where splicing is indicated, all optical fiber cable splicing shall be fusion spliced.
3. Fiber optic cables shall never to be spliced in any outside or underground structure.
4. Only one type of fiber shall occupy each individual fiber splice tray.
5. Mount splice case so it is fully supported on the wall, and available at a working height.
6. Maintain sufficient slack to enable splice case to be removed from the wall for service.

3.4 GROUNDING AND BONDING

- A. Any use of armored cable shall require the bonding of that shield to the PBB or SBB with a #6 AWG copper bonding conductor.
- B. Refer to Section 27 05 26 for additional details.

3.5 TESTING

- A. Refer to Specification Section 27 08 23.

3.6 ACCEPTANCE

- A. The fiber cabinet shall be labeled per specifications. See Section 27 00 02 - APPENDIX B Labeling-Design-Syntax.
- B. Once the testing has been completed and the Cal Poly Designated Telecommunications Representative is satisfied that all work is in accordance with the Contract Documents, the representative will notify the Contractor and/or the Cal Poly Facilities Project Manager in writing or via email.

3.7 RECORD (AS-BUILT) DRAWINGS

- A. None required

END OF SECTION

SECTION 27 11 23 – COMMUNICATIONS CABLE MANAGEMENT AND LADDER RACK

PART 1 - GENERAL

1.1 DESCRIPTION

- A. The work covered by this section of the Specifications includes all labor necessary to perform and complete such construction, all materials and equipment incorporated or to be incorporated in such construction and all services, facilities, tools and equipment necessary or used to perform a complete installation of the Telecommunications Systems and Components. The work of this section shall include, but is not limited to, the following:
- B. MDF, IDF, and SDF ladder racks complete with all necessary installation hardware.

1.2 QUALITY ASSURANCE

- A. Refer to Section 27 00 00 for general details.

1.3 CODES, STANDARDS, AND GUIDELINES

- A. Except as modified by governing codes and by the Contract Documents, comply with the applicable provisions and recommendations in Section 27 00 00.
- B. The University Telecommunication Infrastructure Planning (UTIP) Standards document and Section 27 00 02 - APPENDIX B Labeling-Design-Syntax.
- C. All installations and hardware must meet seismic zone 4 requirements.

1.4 SUBMITTALS

- A. Refer to Section 27 00 00 for general details.
- B. Shop Drawings:
 - 1. Shop drawings shall show the position of ladder racks in the MDF, IDF, or SDF. Ladder racks shall be dimensioned, and the position of the ladder rack shall be dimensioned from (2) walls in each MDF, IDF, or SDF.
 - 2. Shop drawings for ladder racks shall also show the method of attachment to the ceilings.
- C. Submit Manufacturer's Cut Sheets for the following:
 - 1. Any products not specifically listed in the PRODUCTS section shall require a

submittal of the manufacturer's cut sheets and approval by the Cal Poly Designated Telecommunications Representative.

1.5 IDENTIFICATION

- A. None Required

1.6 DEFINITIONS

- A. N/A

1.7 WARRANTY

- A. Refer to Section 27 00 00 for general

details. PART 2 - PRODUCTS

2.1 PRODUCT CONSISTENCY

- A. Product Consistency: Any given item of equipment or material shall be the product of one manufacturer throughout the facility. Multiple manufacturers of any one item will not be permitted.

2.2 APPROVED MANUFACTURERS AND MATERIAL

- A. See Section 27 06 00 – Schedules for Communications for approved manufacturers and material to be supplied for this section.

2.3 LADDER RACK - GENERAL

- A. Unless otherwise noted, finish on all metal components shall be epoxy-polyester hybrid powder coat and grey in color, Hardware will be zinc plated with a gold chemical finish.
- B. Elements shall be provided from the manufacturer as a complete kit, including all fasteners and required hardware.

2.4 LADDER RACK

- A. Ladder rack shall be manufactured from 3/8" wide by 1-1/2" high tubular steel with .065" wall thickness.
- B. Ladder rack (side stringers) will be 9'-11½ " long. Cross members will be welded in between stringers on 12" centers beginning 5-3/4" from one end so that there are 10 cross members per ladder rack. There will be 10-1/2" of open space in between each cross member.
- C. Ladder rack will be delivered individually boxed, and available in 18"widths.

2.5 VERTICAL-TO-HORIZONTAL 90° TURNS (CABLE RUNWAY OUTSIDE RADIUS BEND)

- A. Vertical-to-horizontal 90° turns shall be manufactured from 3/8" wide by 1-

1/2" high tubular steel with .065" wall thickness and shall be available in 18" widths.

- B. Stringers (sides) will be formed in a 90° arc with a 12-1/2" outside radius. Cross members will be welded in between stringers on approximate 23° increments so that there are 3 cross members per turn. The welded assembly will create a smooth 90° vertical-to-horizontal turn.

2.6 HORIZONTAL-TO-VERTICAL 90° TURNS (CABLE RUNWAY INSIDE RADIUS BEND)

- A. Horizontal-to-vertical 90° turns shall be manufactured from 3/8" wide by 1-1/2" high tubular steel with .065" wall thickness and shall be available in 18" widths.
- B. Stringers (sides) will be formed in a 90° arc with a 12-1/2" outside radius. Cross members will be welded in between stringers on approximate 23° increments so that there are 3 cross members per turn. The welded assembly will create a smooth 90° horizontal-to-vertical turn.

2.7 CORNER BRACKETS (CABLE RUNWAY CORNER BRACKET)

- A. Corner brackets shall be manufactured from 3/8" wide by 1-1/2" high tubular steel with .065" wall thickness.
- B. The inside stringers of the corner bracket shall be formed at 90° with a small chamfer at the vertex. The outside stringer of the corner bracket shall be formed in a 90° arc with a 15" radius. A single cross member shall connect the chamfered portion of the inside stringer to the outside stringer. The welded assembly shall create a smooth 90° turn within the L-shaped corner created by two intersecting ladder racks.
- C. Corner brackets shall be available in the size(s) specified below. Installation hardware shall be included with the corner bracket. Corner bracket installation hardware shall not include the junction splice kit required to form the L-shaped intersection between two ladder racks.

2.8 LADDER RACK SPLICES

- A. Splice kits shall provide a method of mechanically connecting ladder rack sections and turns together end-to-end to form a continuous pathway for cables.
- B. Splices (splice plates) shall be manufactured from steel with zinc plating.

2.9 JUNCTION SP SPLICE KITS

- A. Splice kits shall provide a method of mechanically connecting ladder rack

sections and turns together side-to- end to form a continuous pathway for cables.

- B. Splices (splice plates) shall be manufactured from steel with zinc plating.

2.10 LADDER RACK SUPPORTS

A. Ladder Rack Supports for Suspension from an Open Ceiling

1. Supports shall be sized to match the width of the ladder rack that is supported.
2. Each support shall include a means of securing ladder rack to the support.
3. Supports shall be manufactured from steel.
4. Support kit shall utilize no less than a 3/8" threaded rod.

B. Horizontal Ladder Rack Supports for Wall Mounting (Horizontal Wall Angle Support)

1. Supports shall be sized to match the width of the ladder rack that is supported.
2. Each support shall include a means of securing ladder rack to the support.
3. Supports shall be manufactured from steel.
4. Support shall be 2" x 2" x .105" steel angle designed specifically this application.

C. Vertical Ladder Rack Supports for Wall Mounting

1. Supports shall be sized to match the size of the ladder rack stringers that are supported.
2. Supports shall be manufactured from steel.

D. Ladder Rack Supports for Top of Rack

1. Supports shall be sized to match the width of the ladder rack that is supported.
2. Each support shall include a means of securing ladder rack to the support, and the support to the rack.
3. Supports shall be manufactured from steel.
4. The 3" wide mounting plate shall include a hat shaped mounting bracket to secure the plate to the rack top angles without intruding into the rack mounting spaces.

2.11 LADDER RACK ACCESSORIES

A. Ladder Rack Radius Drops

1. Supports shall be sized to match the width of the ladder rack that is supported.
2. Each radius drop mounts to the cross member or stringer and shall be secured with a clevis pin.

3. Radius drop shall provide minimum 3" bend radius, and shall be equipped with three 1½" cable spools.
 4. Supports shall be manufactured from steel or aluminum.
- B. Ladder Rack Grounding
1. Use 8" insulated green #6 AWG stranded copper conductor as bonding. (See Fig.#141 in Section 27 00 02 - APPENDIX B Labeling-Design-Syntax)
 2. Utilizes two-hole, double crimp, compression lugs with 1/4" bolt holes spaced on 5/8" centers.
 3. Shall use all UL Listed components.
- C. End Caps
1. End caps used to cover the ends of ladder rack shall be manufactured from a black fire-retardant rubberized material.
 2. End caps shall be sized to fit stringers 3/8" wide by 1-1/2" high.
- D. Touch-Up Paint
1. Use air dry waterborne paint available in a bottle with applicator.
- 2.12 CABLE MANAGEMENT ACCESSORIES (STRAPS AND TIES)
- A. Cable Straps
1. Construction shall be laminated, as opposed to heat bonded or glued.
 2. Hook side shall be constructed from 100% Polyethylene
 3. Loop Hook side shall be constructed from 100% Nylon
 4. Available in multiple widths and colors, but ¾" black shall be used.
- B. Cable Ties (Indoor)
1. Cable ties shall be used indoors with OSP, riser copper cables only.
 2. Low profile head with parallel-entry (180° entry)
 3. Width shall be at minimum 0.3"
 4. Minimum Loop Tensile Strength of 120lbs.
 5. Material shall be nylon and Black in color.
- C. Cable Ties (Outdoor)
1. Cable ties shall be used outdoors with OSP cables.
 2. Low profile head with parallel-entry (180° entry)

3. Width shall be at minimum 0.3"
 4. Minimum Loop Tensile Strength of 120lbs.
 5. Material shall be weather resistant nylon and Black in color.
- D. Cable Tie Mount
1. Shall employ a cradle design with a recessed #10 screw mounting hole
 2. Material shall be weather resistant nylon and Black in color.
 3. Approved Manufacturer: Panduit or Cal Poly ITS Telecomm group approved

equal PART 3- EXECUTION

3.1 GENERAL

- A. Location and placement of ladder rack shall be as shown on the Drawings or defined in these Specifications and Schedules.
- B. Where cable leaves a pathway to transition to a ladder rack, and that transition spans more than 18", continuous support shall be required.
- C. Ladder rack and all related accessories shall be assembled and installed as per the manufacturers' printed instructions.
- D. Ladder rack and all cable management accessories shall be installed level, plumb, square and placed in a professional workmanship like manner.
- E. The Contractor shall provide touch-up paint color-matched to the finish on the ladder rack and shall correct any minor cosmetic damage (chips, small scratches, etc.) resulting from normal handling during the installation process prior to delivery to the University. If a component is cosmetically damaged to the extent that correction in the field is obvious against the factory finish, the component shall be replaced with a new component finished from the factory.
- F. If a component is physically damaged or exhibiting rust due to mishandling, improper storage or modification during the installation process, it shall not be used.
- G. Any excess length of bolts or threaded rods shall be trimmed to no more than 1/2" past the nut and de-burred.
- H. All exposed sharp edges shall be filed smooth.
- I. Do not install cabling using the ladder rack until after the ladder rack installation has been approved by the Cal Poly Designated Telecommunications Representative.

3.2 QUANTITIES

- A. Quantities and sizes of ladder rack and components shown on the Drawings are illustrative only and shall be meant to indicate the general configuration of the work. The Contractor shall be responsible for providing the correct quantities of all materials necessary to accommodate the equipment and to terminate, cross connect and patch the volume of cable described in these specifications and schedules and shown on the Drawings
- B. Ladder Rack Radius Drops
 - 1. Cable Runway Radius Drops shall be required in any instance where a cable or transitions on or off ladder racking, except where the cable enters from above. Contractor shall supply a minimum of three spare Cable Runway Radius Drops for Stringers per MDF, IDF, or SDF.

3.3 INSTALLATION

- A. Ladder Rack
 - 1. Ladder rack shall be installed with side stringers facing down so that the ladder forms an inverted U-shape and so that welds between the stringers (sides) and cross members (middle) face away from cables.
 - 2. Ladder rack shall be secured to the structural ceiling, building truss system, wall, floor or the tops of equipment racks using the manufacturer's recommended supports and appropriate installation hardware and methods as defined by local code or the Authority Having Jurisdiction.
 - 3. Ladder rack splices shall be made in mid-span, not over a support, with the manufacturer's recommended splice hardware.
 - 4. At each splice point or termination cut the ladder rack ¼" short to allow for thermal expansion.
 - 5. Maintain correct cross member spacing when splicing ladder rack sections.
 - 6. Ladder rack shall be supported every 5' or less in accordance with TIA-569-B. Where additional support is required for runs over 5', ladder rack shall be supported from the hard ceiling.
 - 7. Ladder rack shall be supported within 2' of every splice and within 2' on both/all sides of every intersection. Support ladder rack within 2' on both sides of every change in elevation. Support ladder rack every 2' when attached vertically to a wall.

8. Ladder rack installed parallel to the wall shall be placed with a 4" offset (gap) from the wall.
 9. Leave a minimum of 12" in between ladder rack and mechanical systems, lighting fixtures, ceiling or any other obstructions. If multiple tiers of ladder rack are required, they shall be installed with a minimum clearance of 12" in between each tier of ladder rack.
 10. The quantity of cables within the ladder rack shall not exceed the manufacturer's product specifications for each product. Actual cable fill for ladder rack shall not exceed 6" in height.
 11. The combined weight of cables within the ladder rack shall not exceed the stated load capacity of the ladder rack as stated in the manufacturer's product specifications or load/design tables.
 12. When a single ladder rack supports different types of cable media, the cable media shall be separated within the pathway. Treat each type of cable media and divided area of the ladder rack separately when determining cable fill limits.
 13. Use a radius drop to guide cables wherever cable exits overhead ladder.
 14. Cover the exposed ends of cable runway that do not terminate against a wall, the floor or the ceiling with end caps.
- B. Cable Ties & Straps
1. Riser, Tie and OSP Cables shall be secured at every cross member of ladder rack with cable ties.
 2. Station Cables (cable bundles) shall be secured to every cross member of ladder rack with reusable Hook and Loop straps.
 3. Cable Tie Mounts spaced 12" on center shall be used to support cable runs on backboard.
 4. Riser, Tie and OSP Copper Cables shall use cable ties in all locations, station cables shall use reusable Hook and Loop straps in all locations.

3.4 GROUNDING AND BONDING

- A. Within each MDF, IDF, or SDF, ladder rack shall be bonded together, electrically continuous, and bonded to the PBB or SBB.
- B. Ladder rack and transition elements shall be bonded across each splice with a bonding kit. Ladder rack shall be bonded to the PBB or SBB using an approved, two-hole nonreversible ground lug on the ladder rack and a minimum #6

grounding wire.

- C. Remove paint from the ladder rack where bonding/ground lugs contact the ladder rack so that the lug shall contact bare metal or use star washers between the nut and the stringer.
- D. Use antioxidant joint compound in all locations where bonding/grounding elements are mechanically attached.
- E. Verify continuity through the bonds at splices and intersections between individual ladder rack sections and turns and through the bond to the PBB or SBB.
- F. Install all grounding and bonding components per the manufacturer's written specifications. Refer to Section 27 05 26 for additional details.

3.5 TESTING

- A. Non Required

3.6 ACCEPTANCE

- A. Any deviation from the approved Drawings shall require submission and approval of the revised shop drawings by the Cal Poly Designated Telecommunications Representative before the installation begins.
- B. Once the testing has been completed and the Cal Poly Designated Telecommunications Representative is satisfied that all work is in accordance with the Contract Documents, the representative will notify the Contractor and/or the Cal Poly Facilities Project Manager in writing or via email.

3.7 RECORD (AS-BUILT) DRAWINGS

- 1. The Project Record Drawings shall show the types and locations of installed ladder rack.

END OF SECTION

SECTION 27 13 13 – COMMUNICATIONS COPPER BACKBONE CABLING

PART 1 - GENERAL

1.1 DESCRIPTION

- A. The work covered by this section of the Specifications includes all labor necessary to perform and complete such construction, all materials and equipment incorporated or to be incorporated in such construction and all services, facilities, tools and equipment necessary or used to perform a complete installation of the Telecommunications Systems and Components. The work of this section shall include, but is not limited to, the following:
 - 1. A complete copper twisted pair backbone cabling system to support voice circuit distribution as well as data communications with cables, termination hardware, splices, and necessary installation and supporting hardware.

1.2 QUALITY ASSURANCE

- A. Refer to Section 27 00 00 for general details.
- B. All contractors and installers working on structured cabling system elements shall hold a current manufacturer's certification for each individual component they install.

1.3 CODES, STANDARDS, AND GUIDELINES

- A. Except as modified by governing codes and by the Contract Documents, comply with the applicable provisions and recommendations in Section 27 00 00.
- B. The University Telecommunication Infrastructure Planning (UTIP) Standards document and Section 27 00 02 - APPENDIX B Labeling-Design-Syntax.

1.4 SUBMITTALS

- A. Refer to Section 27 00 00 for general details.
- B. Shop Drawings:
 - 1. Shop drawings shall show cable routing details.
- C. Submit Manufacturer's Cut Sheets for the following:
 - 1. Any products not specifically listed in the PRODUCTS section shall require a

submittal of the manufacturer's cut sheets and approval by the Cal Poly Designated Telecommunications Representative.

D. Manufacturers Testing:

1. Submit as testing results as required by Section 27 08 13.
2. Multi-pair copper riser cables: The Contractor shall submit two (2) sets of the manufacturer's test results for continuity, shorts and breaks.

1.5 IDENTIFICATION

- A. Machine generated, 1", nylon labels with black lettering shall be placed on all copper backbone and riser cables.
- B. Labels containing a unique cable ID designator developed by the Contractor using the labeling shown in Section 27 00 02 - APPENDIX B Labeling-Design-Syntax and approved by the Cal Poly Designated Telecommunications Representative shall be placed on both ends of all cables, 6 inches from the termination and/or terminal block, and in all pull boxes in the pathway.
- C. Subsequent to placing and terminating cables, the Contractor shall place the appropriate labels as indicated above.
- D. If at any time during the job the label becomes illegible or removed for whatever reason, the Contractor shall immediately replace it with a new label at the Contractor's expense.
- E. All labels shall be easily accessible, both physically and visually, upon completion of the job.
- F. Refer to Section 27 05 53 for additional details.

1.6 DEFINITIONS

- A. Backbone Cable as defined in this section shall be intra-building riser cable for use between MDF, IDFs, and SDFs.
- B. OSP Cable as defined in Section 27 13 14 is inter-building cable for use between MDFs.

1.7 WARRANTY

- A. Refer to Section 27 00 00 for general

details. PART 2 - PRODUCTS

2.1 PRODUCT CONSISTENCY

- A. Product Consistency: Any given item of equipment or material shall be the product of one manufacturer throughout the facility. Multiple manufacturers of

any one item will not be permitted.

2.2 APPROVED MANUFACTURERS AND MATERIAL

- A. See Section 27 06 00 – Schedules for Communications for approved manufacturers and material to be supplied for this section.

2.3 COPPER CABLES - GENERAL

- A. Cable jacket marking: Must be legible and shall contain the following information:
 1. Manufacturer's name
 2. Copper Conductor Gauge
 3. Pair Count
 4. UL and CSA listing
 5. Manufacturer's Trade Mark
 6. Category rating
 7. Sequential foot markings, in one foot increments

2.4 COPPER CABLE (BACKBONE)

- A. Cable jacket shall be gray, plenum rated, with black lettering.
- B. Cable must be ARMM riser rated.
- C. Cable construction specifications:
 1. Core wrap - Polypropylene Film.
 2. Shield - Corrugated Aluminum tape bonded to riser rated jacket.
- D. The cables consist of 22 AWG foam polyethylene insulated conductors with plenum rated skin formed into binder groups of 25 pairs using standard PIC color coding.

PART 3- EXECUTION

3.1 GENERAL

- A. Location and placement of backbone cables shall be shown on the Drawings. Submit Shop Drawings to the Cal Poly Designated Telecommunications Representative for approval of block field, protector and splice case layouts and locations as well as OSP cable routing before starting work.
- B. Backbone copper cabling shall not share pathways with backbone fiber cabling or any horizontal cable unless approved in advance by the Cal Poly Designated Telecommunications Representative.

- C. Backbone copper cabling shall be installed point to point. Terminating a subgroup of conductors from a cable within a conduit and continuing to another location shall not be allowed.
- D. Absolutely no in-line splicing of backbone copper cabling shall be allowed.
- E. Contractor is to verify (in advance) sufficient end to end pathway fill ratios for cable runs prior to installation.
- F. No cross-connects shall be installed until after the backbone cable test reports have been reviewed and accepted by the Cal Poly Designated Telecommunications Representative. All cross-connects shall typically be installed by the Cal Poly ITS Telecomm Group.

3.2 QUANTITIES

- A. Quantities of system elements shown on the drawings are illustrative only and are meant to indicate the general configuration of the work. The Contractor shall be responsible for providing the correct quantities of materials to construct a system that meets the intent of these Specifications and the relevant codes.

3.3 INSTALLATION

- A. Cabling:
 - 1. Unless otherwise noted, all backbone cables shall be routed through continuous conduit from point to point.
 - 2. All backbone cable, once exposed, shall be provided with appropriate support.
 - 3. At the same time cable is pulled into a conduit also install a pull rope to facilitate future cable pulls along those pathways. Pull rope shall be (minimum) nylon 1/4" with 600 lb. pulling tension.
 - 4. Cables running on ladder racking within an MDF, IDF, or SDF shall be neatly placed and lashed to the horizontal and vertical ladder racking with wire ties at every rung.
- B. Cable Terminations
 - 1. All riser cables shall be "punched down" on 66 blocks in the MDF, IDF, or SDF.
 - 2. Cable pair twists shall be maintained up to within 1/2 in. of the point of termination for backbone cables. For other backbone cables, maintain twists as close as practicable to the point of termination. Under no circumstances shall cable pairs be untwisted or otherwise altered prior to termination.
 - 3. All terminations shall follow industry standard uniform color codes.

3.4 GROUNDING AND BONDING

- A. All termination locations for backbone copper cable shall bond the cable shield to the PBB or SBB with a #6 AWG copper bonding conductor.
- B. Refer to Section 27 05 26 for additional details.

3.5 TESTING

- A. For testing details see Section 27 08 13.

3.6 ACCEPTANCE

- A. Upon receipt of the Contractor's documentation of testing, the Cal Poly Designated Telecommunications Representative shall review/observe the installation and may randomly request tests of the cables/wires installed.
- B. Once the testing has been completed and the Cal Poly Designated Telecommunications Representative is satisfied that all work is in accordance with the Contract Documents, the representative will notify the Contractor and/or the Cal Poly Facilities Project Manager in writing or via email.

3.7 RECORD (AS-BUILT) DRAWINGS

- A. The Project Record Drawings shall show the types and locations of all backbone cabling. Drawings shall include identifying information from the cable identification labels.

END OF SECTION

SECTION 27 13 14 – COMMUNICATIONS COPPER OSP CABLING

PART 1 - GENERAL

1.1 DESCRIPTION

- A. The work covered by this section of the Specifications includes all labor necessary to perform and complete such construction, all materials and equipment incorporated or to be incorporated in such construction and all services, facilities, tools and equipment necessary or used to perform a complete installation of the Telecommunications Systems and Components. The work of this section shall include, but is not limited to, the following:
 - 1. A complete copper twisted pair outside plant (OSP) backbone cabling system to support voice circuit distribution as well as data communications with cables, termination hardware, splices, and necessary installation and supporting hardware.

1.2 QUALITY ASSURANCE

- A. Refer to Section 27 00 00 for general details.
- B. All contractors and installers working on structured cabling system elements shall hold a current manufacturer's certification for each individual component they install.

1.3 CODES, STANDARDS, AND GUIDELINES

- A. Except as modified by governing codes and by the Contract Documents, comply with the applicable provisions and recommendations in Section 27 00 00.
- B. The University Telecommunication Infrastructure Planning (UTIP) Standards document and Section 27 00 02 - APPENDIX B Labeling-Design-Syntax.
- C. Customer Owned Outside Plant Design Manual (BICSI)

1.4 SUBMITTALS

- A. Refer to Section 27 00 00 for general details.
- B. Shop Drawings:
 - 1. Shop drawings shall show the OSP backbone pathways, locations and type of terminal blocks, entrance protectors, pair counts and cable designations at termination points.
 - 2. Shop drawings shall show the layout of the distribution frames in the MDF

and the IDFs and SDFs with pair counts by each wiring block.

3. Submit Shop Drawings to the Cal Poly Designated Telecommunications Representative for approval of block field, protector and splice case layouts and locations as well as OSP cable routing before starting work.

C. Submit Manufacturer's Cut Sheets for the following:

1. Any products not specifically listed in the PRODUCTS section shall require a submittal of the manufacturer's cut sheets and approval by the Cal Poly Designated Telecommunications Representative.

D. Manufacturers Testing:

1. Submit as testing results as required by Section 27 08 13.

1.5 IDENTIFICATION

A. Outdoor cables must be labeled with 1" white nylon labels with black machine generated lettering within 18" of all conduit endpoints and both cable endpoints. Within all underground structures larger than 3' in any dimension, label each cable as it enters the structure, and when it exits the structure.

B. Refer to Section 27 05 53 for additional details.

1.6 DEFINITIONS

A. N/A

1.7 WARRANTY

A. Refer to Section 27 00 00 for general

details. PART 2 - PRODUCTS

2.1 PRODUCT CONSISTENCY

A. Product Consistency: Any given item of equipment or material shall be the product of one manufacturer throughout the facility. Multiple manufacturers of any one item will not be permitted.

2.2 APPROVED MANUFACTURERS AND MATERIAL

A. See Section 27 06 00 – Schedules for Communications for approved manufacturers and material to be supplied for this section.

2.3 COPPER OSP CABLES - GENERAL

A. Cable jacket marking: Must be legible and shall contain the following information:

1. Manufacturer's name
2. Copper Conductor Gauge

3. Pair Count
4. UL and CSA listing
5. Manufacturer's Trademark
6. Category rating
7. Sequential foot markings, in one-foot increments

2.4 COPPER OSP CABLE (BACKBONE CABLE)

- A. Cables shall be specifically PE89, gel filled, qualpeth sheathed with aluminum shield, 22 AWG, multi-pair cables.
- B. See Drawings for required pair counts.
- C. Minimum performance specifications: The cables shall meet the requirements of ANSI/EIA/TIA-568B for 100- Ohm UTP Multi-pair Backbone Cable.

2.5 COPPER OSP CABLE (CAT 6A STATION CABLE)

- A. Cable shall be Category 6A UTP Cable, outdoor, flooded gel, black jacket, 4 pair count.

2.6 COPPER OSP CABLE (CAT 3 STATION CABLE)

- A. Cable shall be Category 3 UTP Cable, outdoor, black jacket with a rip cord, 6 pair count.
- B. Cable shall be suitable for direct burial, gel filled, with an aluminum

shield. PART 3- EXECUTION

3.1 GENERAL

- A. Location and placement of termination blocks and cable types shall be as shown on the Drawings.
- B. Do not install cross-connects until after the cable test reports have been accepted by the Cal Poly Designated Telecommunications Representative. Cross-connects are typically installed by the Cal Poly ITS Telecomm Group.

3.2 QUANTITIES

- A. Quantities of system elements shown on the drawings shall be illustrative only and are meant to indicate the general configuration of the work. The Contractor shall be responsible for providing the correct quantities of materials to construct a system that meets the intent of these Specifications and the relevant codes.

3.3 INSTALLATION

A. OSP Cable Installation

1. Install OSP cables in accordance with all Specifications and Drawings.
2. All OSP cables shall run from the termination locations indicated on the copper cable riser diagram or site plan through the dedicated pathways and spaces identified in the Telecommunications Drawings and into their respective MDF.
3. All OSP cables shall be terminated on protector panels in the MDF.
4. Cables terminating at an outside endpoint shall be required to have an entrance protector covering all pairs, including spares.
5. Cables running on ladder racking within an MDF shall be neatly placed and lashed to the horizontal and vertical ladder racking with wire ties at every rung.
6. At the same time cable is pulled into a conduit also install a pull rope to facilitate future cable pulls along all pathways. Pull rope to be (minimum) nylon ¼" 600 lb. pulling tension.
7. Observe all manufacturers' written specifications, specifically in regard to pulling tensions for cables and allowable methodologies for installation.

B. Cable Terminations

1. Cable pair twists shall be maintained up to within ½ in. of the point of termination.
2. Under no circumstances shall cable pairs be untwisted or otherwise altered prior to termination.
3. All terminations shall follow industry standard uniform color codes.

C. Gel Sealant

1. All gel filled cables shall require use of a gel blocking sealant at any point that the gel is exposed.
2. Follow all manufacturers' specifications for proper application of gel block sealant.

3.4 GROUNDING AND BONDING

- A. Each OSP cable shall be grounded with a Shield Bond Connector via a #6 AWG copper wire to the PBB or ground rod if at an outside endpoint.
- B. Each protector shall be individually grounded via a #6 AWG copper wire to the

PBB or ground rod if at an outside endpoint.

C. Refer to Section 27 05 26 for additional details.

3.5 TESTING

A. For testing details see Section 27 08 13

3.6 ACCEPTANCE

A. 100% of the copper pairs tested per cable shall meet requirements for the whole of the installation to be accepted.

B. Once the testing has been completed and the Cal Poly Designated Telecommunications Representative is satisfied that all work is in accordance with the Contract Documents, the representative will notify the Contractor and/or the Cal Poly Facilities Project Manager in writing or via email.

3.7 RECORD (AS-BUILT) DRAWINGS

A. The Project Record Drawings shall show the types and locations of all OSP cabling, and all OSP termination points. Drawings shall include identifying information from the cable label.

B. Provided documentation shall include Butterfly Drawings for each vault, detailing specific conduit utilization for each cable.

END OF SECTION

SECTION 27 13 23 – COMMUNICATION OPTICAL FIBER BACKBONE CABLING

PART 1 - GENERAL

1.1 DESCRIPTION

- A. The work covered by this section of the Specifications includes all labor necessary to perform and complete such construction, all materials and equipment incorporated or to be incorporated in such construction and all services, facilities, tools and equipment necessary or used to perform a complete installation of the Telecommunications Systems and Components. The work of this section shall include, but is not limited to, the following:

- 1. Optical fiber backbone cabling

1.2 QUALITY ASSURANCE

- A. Refer to Section 27 00 00 for general details.
- B. All contractors and installers working on structured cabling system elements must hold a current manufacturer's certification for each individual component they install.

1.3 CODES, STANDARDS, AND GUIDELINES

- A. Except as modified by governing codes and by the Contract Documents, comply with the applicable provisions and recommendations in Section 27 00 00.
- B. The University Telecommunication Infrastructure Planning (UTIP) Standards document and Section 27 00 02 - APPENDIX B Labeling-Design-Syntax.

1.4 SUBMITTALS

- A. Except as modified by governing codes and by the Contract Documents, comply with the applicable provisions and recommendations in Section 27-00-00.
- B. TIA-492-AAAD
- C. ITU-T G.652D
- D. Submit Manufacturer's Cut Sheets for the following:
 - 1. Any products not specifically listed in the PRODUCTS section shall require a submittal of the manufacturer's cut sheets and approval by the Cal Poly Designated Telecommunications Representative.

1.5 IDENTIFICATION

- A. All fiber optic backbone and riser cables must be labeled with 1" nylon label with black machine generated lettering at each endpoint and each time it enters or exits an underground facility or vault.
- B. All labels shall be easily accessible, both physically and visually, upon completion of the job.
- C. Refer to Section 27 05 53 for additional details.

1.6 DEFINITIONS

- A. CMP: Communications Plenum Cable
- B. CMR: Communications Riser Cable
- C. MPP: Multipurpose Plenum Cable
- D. OFNP: Optical Fiber Nonconductive Plenum Cable
- E. OFCP: Optical Fiber Conductive Plenum Cable
- F. LSZR: Low Smoke Zero Halogen Rated Cable
- G. OM1: Defined by ISO 11801 & TIA-492-AAAA, 62.5/125 μm multimode fiber.
- H. OM2: Defined by ISO 11801 & TIA-492-AAAB, 50/125 μm multi-mode fiber.
- I. OM3: Defined by ISO 11801 & TIA-492-AAAC, laser-optimized 50/125 μm multi-mode fiber
- J. OM4: Defined by TIA-492-AAAD, laser-optimized 50/125 μm multi-mode fiber
- K. OS1: Singlemode, Specified for 1310 and 1550 nm. At 1383 nm (water peak), attenuation is reduced to 1 dB.

1.7 WARRANTY

- A. Refer to Section 27 00 00 for general

details. PART 2 - PRODUCTS

2.1 PRODUCT CONSISTENCY

- A. Any given item of equipment or material shall be the product of one manufacturer throughout the facility. Multiple manufacturers of any one item will not be permitted.

2.2 APPROVED MANUFACTURERS AND MATERIAL

- A. See Section 27 06 00 – Schedules for Communications for approved manufacturers and material to be supplied for this section.

2.3 FIBER OPTIC CABLES - GENERAL

- A. Cable jacket marking: Must be legible and shall contain the following information:
 - 1. Manufacturer's name and/or trademark
 - 2. Strand count
 - 3. Core Type
 - 4. Core Count
 - 5. UL listing
 - 6. Sequential distance markings, in one-foot increments
- B. All multimode fiber (UON) shall be OM4, 50µm, laser optimized, multimode fiber.
- C. All single mode shall be zero water peak single mode fiber

2.4 OPTICAL FIBER PLENUM RISER CABLE

- A. Non-armored, gel free, plenum rated distribution cable
- B. Jacket color for 50µm multimode fiber shall be aqua.
- C. Jacket color for single mode fiber shall be

yellow. PART 3- EXECUTION

3.1 GENERAL

- A. Backbone (Non OSP) fiber optic cables are for use between telecommunications facilities within the same building.
- B. Location, fiber count and placement detail for all fiber optic cables shall be as shown on the Drawings.
- C. Provide 20' slack loops at the MDF, IDF, or SDF end of all backbone fiber optic cables.
- D. Provide 60" of stripped strands fiber wrapped neatly at each fiber cabinet.
- E. Ensure all fiber optic cables as installed are not subject to strain, and that correct bend radiuses are maintained at all times.
- F. Each fiber optic riser cable shall be placed within one cell of innerduct per Section 27 05 33
- G. Fiber optic cables and copper cables shall not share conduit or innerduct.
- H. Do not terminate fiber until after the rack locations and elevations of fiber cabinets have been approved by the Cal Poly Designated Telecommunications Representative.
- I. Patch cables shall not be installed until after the fiber optic test reports have been

approved by the Cal Poly Designated Telecommunications Representative. The Cal Poly ITS Telecomm Group typically installs all patch cables.

3.2 QUANTITIES

- A. Quantities of system elements shown on the drawings are illustrative only and are meant to indicate the general configuration of the work. The Contractor shall be responsible for providing the correct quantities of materials to construct a system that meets the intent of these Specifications and the relevant codes.

3.3 INSTALLATION

- A. Optical Fiber Backbone Cables:
 - 1. Provide support for vertical runs of fiber optic riser cables.
 - 2. Route fiber optic cables over telecom ladder racking.
 - 3. Route fiber optic cables together as a single bundle, not to be combined with copper or coax cabling.
 - 4. Installation of all fiber optic cables shall require the use of a breakaway swivel rated to the cable manufacturer's written specifications for pull strength.
 - 5. Follow all manufacturers' specifications for installation.
- B. Connector Installation
 - 1. Fiber Optic cabling shall be terminated using fusion-spliced color coded (following fiber standards) pigtails only.
 - 2. Maximum length differential between terminated strands per bundle shall be 2". If the length does not meet this requirement the entire bundle must be re-terminated.
- C. Slack Loop
 - 1. Slack loop shall be mounted on the wall, above ladder rack height.
 - 2. Slack loop location shall be designated by the Cal Poly Designated Telecommunications Representative.

3.4 GROUNDING AND BONDING

- A. Any use of armored cable shall require the bonding of that shield to the PBB with a #6 AWG copper bonding conductor.
- B. Refer to Section 27 05 26 for additional details.

3.5 TESTING

- A. Refer to Specification Section 27 08 23.

3.6 ACCEPTANCE

- A. 100% of the fiber tested must meet requirements for the whole of the fiber installation to be accepted. Marginal pass will not be accepted.
- B. Upon receipt of the Contractor's cable testing documentation, the Cal Poly Designated Telecommunications Representative shall review/observe the installation and/or randomly request tests of the cables installed.
- C. Once the testing has been completed and the Cal Poly Designated Telecommunications Representative is satisfied that all work is in accordance with the Contract Documents, the representative will notify the Contractor and/or the Cal Poly Facilities Project Manager in writing or via email.

3.7 RECORD (AS-BUILT) DRAWINGS

- A. The Project Record Drawings shall show the types and locations of all fiber optic cabling and fiber optic termination points. Drawings should include identifying information from the cable labels.

END OF SECTION

SECTION 27 13 24 – COMMUNICATIONS OPTICAL FIBER OSP CABLING

PART 1 - GENERAL

1.1 DESCRIPTION

- A. The work covered by this section of the Specifications includes all labor necessary to perform and complete such construction, all materials and equipment incorporated or to be incorporated in such construction and all services, facilities, tools and equipment necessary or used to perform a complete installation of the Telecommunications Systems and Components. The work of this section shall include, but is not limited to, the following:

- 1. OSP optical fiber backbone cabling system.

1.2 QUALITY ASSURANCE

- A. Refer to Section 27 00 00 for general details.
- B. All contractors and installers working on structured cabling system elements shall hold a current manufacturer's certification for each individual component they install.

1.3 CODES, STANDARDS, AND GUIDELINES

- A. Except as modified by governing codes and by the Contract Documents, comply with the applicable provisions and recommendations in Section 27 00 00.
- B. The University Telecommunication Infrastructure Planning (UTIP) Standards document and Section 27 00 02 - APPENDIX B Labeling-Design-Syntax.
- C. Customer Owned Outside Plant Design Manual (BICSI)

1.4 SUBMITTALS

- A. Refer to Section 27 00 00 for general details.
- B. Shop Drawings:
 - 1. Shop drawings shall show the locations where cables are to be routed and where terminating hardware is to be installed.
- C. Submit Manufacturer's Cut Sheets for the following:
 - 1. Any products not specifically listed in the PRODUCTS section shall require a

submission of the manufacturer's cut sheets and approval by the Cal Poly Designated Telecommunications Representative.

1.5 IDENTIFICATION

- A. Outdoor cables shall be labeled with a 1" wide machine-generated, white nylon label with characters in black ink, within 18" of all conduit endpoints as well as on both cable endpoints. Within all underground structures larger than 3' in any dimension, label each cable as it enters and exits the structure.
- B. Refer to Section 27 05 53 for additional details.
- C. Refer to Section 27 00 02 - APPENDIX B Labeling-Design-Syntax.

1.6 DEFINITIONS

- A. CMP: Communications Plenum Cable
- B. CMR: Communications Riser Cable
- C. MPP: Multipurpose Plenum Cable
- D. OFNP: Optical Fiber Nonconductive Plenum Cable
- E. OFCP: Optical Fiber Conductive Plenum Cable
- F. LSZR: Low Smoke Zero Halogen Rated Cable
- G. OM1: Defined by ISO 11801 & TIA-492-AAAA, 62.5/125 μm multi-mode fiber. (old Campus Standard)
- H. OM2: Defined by ISO 11801 & TIA-492-AAAB, 50/125 μm multi-mode fiber.
- I. OM3: Defined by ISO 11801 & TIA-492-AAAC, laser-optimized 50/125 μm multi-mode fiber
- J. OM4: Defined by TIA-492-AAAD, laser-optimized 50/125 μm multi-mode fiber (new Campus Standard)
- K. OS1: Singlemode, Specified for 1310 and 1550 nm. At 1383 nm (water peak), attenuation is reduced to 1 dB.

1.7 WARRANTY

- A. Refer to Section 27 00 00 for general

details. PART 2 - PRODUCTS

2.1 PRODUCT CONSISTENCY

- A. Any given item of equipment or material shall be the product of one manufacturer throughout the facility. Multiple manufacturers of any one item shall not be permitted.

2.2 APPROVED MANUFACTURERS AND MATERIAL

- A. See Section 27 06 00 – Schedules for Communications for approved manufacturers and material to be supplied for this section.

2.3 FIBER OPTIC CABLES - GENERAL

- A. Cable jacket marking: Must be legible and shall contain the following information:
 - 1. Manufacturer's name and/or trademark
 - 2. Strand count
 - 3. Cable Type
 - 4. Pair Count
 - 5. UL listing
 - 6. Sequential distance markings, in one-foot increments
- B. All multimode fiber (UON) cable shall be OM4, 50µm multimode fiber.
- C. All single-mode shall be zero water peak single-mode fiber

2.4 MULTIMODE OPTICAL FIBER OSP CABLE:

- A. Shall be Non-Armored, Jacket MDPE, with strength elements and zip-cord immediately underneath.
- B. Internal structure shall include water swellable tape layer and 2 mm gel filled buffer tubes.
- C. Fibers shall be contained in loose tube construction surrounding a central dielectric strength member
- D. Shall be 12 strands per subunit, with required number of multimode fibers in one overall jacket.
- E. Jacket color shall be black.

2.5 SINGLEMODE OPTICAL FIBER OSP CABLE

- A. Non-Armored Jacket shall be MDPE, with strength elements and zip cord immediately underneath.
- B. Internal structure shall include water swellable tape layer.
- C. Fibers shall be contained in loose tube construction surrounding a central dielectric strength member
- D. Shall be 12 strands per subunit, with the required number of singlemode fibers in one overall jacket.

- E. Jacket color shall be black.

2.6 MULTIMODE OPTICAL FIBER INDOOR/OUTDOOR CABLE

- A. Non-Armored Jacket shall be plenum and OSP rated
- B. Cable shall have aramid yarn and zip-cord immediately underneath jacket.
- C. Internal structure shall include water barrier layer and a central dielectric strength member
- D. Jacket color shall be black.

2.7 SINGLE MODE OPTICAL FIBER INDOOR/OUTDOOR CABLE

- A. Non-Armored Jacket shall be plenum and OSP rated
- B. Cable shall have aramid yarn and zip-cord immediately underneath jacket.
- C. Internal structure shall include water barrier layer and a central dielectric strength member
- D. Jacket color shall be black.

2.8 MULTIMODE OSP FIBER INDOOR PLENUM-RATED CABLE

- A. Shall have a non-armored jacket and be plenum rated.
- B. Shall have aramid yarn and zip cord immediately under the cable jacket.
- C. Shall have an internal structure that includes water barrier and a central dielectric strength member.
- D. Jacket color shall be aqua.

2.9 SINGLE MODE OSP FIBER INDOOR PLENUM-RATED CABLE

- A. Shall have a non-armored jacket and be plenum rated.
- B. Shall have aramid yarn and zip cord immediately under the cable jacket.
- C. Shall have an internal structure that includes water barrier and a central dielectric strength member.
- D. Jacket color shall be

yellow. PART 3- EXECUTION

3.1 GENERAL

- A. OSP fiber optic cables shall be used between telecommunications facilities in different buildings, or for any connections that are subject to moisture.
- B. Location, fiber count and placement detail for all fiber optic cables shall be as shown on the Drawings.

- C. OSP cable shall be run through continuous conduit and/or manholes until it is exposed in a MDF where it is to be terminated.
- D. Provide 50' slack loops at the MDF end of all OSP fiber optic cables over 12 strands. OSP fiber optic cables under 12 strands shall have 20' slack loops.
- E. Provide 60" of stripped fiber strands wrapped neatly at each fiber cabinet.
- F. Ensure all fiber optic cables as installed are not subject to strain, and that correct bend radiuses are maintained at all times.
- G. Fiber optic cables and copper cables shall not share conduit or innerduct unless approved in advance by the Cal Poly Designated Telecommunications Representative.
- H. Do not terminate fiber until after the rack locations and elevations of fiber cabinets have been accepted by the Cal Poly Designated Telecommunications Representative.
- I. Do not install patch cables. After the fiber optic cable test reports have been accepted by the Cal Poly Designated Telecommunications Representative, the Cal Poly ITS Telecom Group shall install all patch cables.

3.2 QUANTITIES

- A. Quantities of system elements shown on the drawings shall be illustrative only and are meant to indicate the general configuration of the work. The Contractor shall be responsible for providing the correct quantities of materials to construct a system that meets the intent of these Specifications and the relevant codes.

3.3 INSTALLATION

- A. Optical Fiber OSP Cables:
 - 1. Provide support for vertical runs of fiber optic riser cables.
 - 2. Route fiber optic cables over telecom ladder racking.
 - 3. Route fiber optic cables together as a single bundle, not to be combined with copper or coax cabling.
 - 4. Installation of all fiber optic cables shall require the use of a breakaway swivel rated to the cable manufacturer's written specifications for pull strength.
 - 5. Follow all manufacturers' specifications for installation.
- B. Connector Installation

1. Terminate both ends of each fiber with an appropriate fusion spliced color-coded (following fiber standards) pigtail. Fibers shall be terminated in strict compliance with the manufacturer's printed instructions.
 2. Maximum length differential between terminated strands per bundle shall be 6". If the length does not meet this requirement the entire bundle must be re-terminated.
- C. Slack Loop
1. Slack loop shall be coiled and mounted on the wall. (See Fig. #139 in Section 27 00 02 - APPENDIX B Labeling-Design-Syntax)
 2. Slack loop location shall be designated by the Cal Poly Designated Telecommunications Representative.
- D. Underground
1. OSP fiber optic cables shall be lashed to and supported by cable management arms within any underground facilities.
 2. Outdoor cables shall be labeled with a 1", machine generated, white nylon label, with characters in black ink at each location, within 12" of where it enters or exits in each underground facility.
 3. At each vault, each fiber optic OSP cable shall make two complete horizontal wrap of the vault before continuing along its pathway.
- 3.4 GROUNDING AND BONDING
- A. None Required
- 3.5 TESTING
- A. Refer to Specification Section 27 08 23.
- 3.6 ACCEPTANCE
- A. 100% of the fiber plant shall be tested and shall meet all requirements and specifications as stated by the manufacturer and in the Contract Documents to receive final approval by the Cal Poly Designated Telecommunications Representative.
- B. Upon receipt of the Contractor's documentation of cable testing, the Cal Poly Designated Telecommunications Representative will review/observe the installation and randomly request tests of the cables installed.
- C. Once the testing has been completed and the Cal Poly Designated Telecommunications Representative is satisfied that all work is in accordance

with the Contract Documents, the representative will notify the Contractor and/or the Cal Poly Facilities Project Manager in writing or via email.

3.7 RECORD (AS-BUILT) DRAWINGS

- A. The Project Record Drawings shall show the types and locations of all fiber optic cabling and fiber optic termination points. Drawings shall include identifying information as indicated on the cable labels.
- B. Provided documentation shall include butterfly drawings for each vault, detailing specific conduit utilization for each cable.

END OF SECTION

SECTION 27 15 23 – FIBER OPTIC STATION CABLES

PART 1 - GENERAL

1.1 DESCRIPTION

- A. The work covered by this section of the Specifications includes all labor necessary to perform and complete such construction, all materials and equipment incorporated or to be incorporated in such construction and all services, facilities, tools and equipment necessary or used to perform a complete installation of the Telecommunications Systems and Components. The work of this section shall include, but is not limited to, the following:

- 1. Optical fiber station cabling

1.2 QUALITY ASSURANCE

- A. Refer to Section 27 00 00 for general details.
- B. All contractors and installers working on structured cabling system elements shall hold a current manufacturer's certification for each individual component they install.

1.3 CODES, STANDARDS, AND GUIDELINES

- A. Except as modified by governing codes and by the Contract Documents, comply with the applicable provisions and recommendations in Section 27 00 00.
- B. The University Telecommunication Infrastructure Planning (UTIP) Standards document and Section 27 00 02 - APPENDIX B Labeling-Design-Syntax.

1.4 SUBMITTALS

- A. Refer to Section 27 00 00 for general details.
- B. Shop Drawings:
 - 1. Shop drawings shall show the locations where cables are to be routed and where terminating hardware is to be installed.
- C. Submit Manufacturer's Cut Sheets for the following:
 - 1. Any products not specifically listed in the PRODUCTS section shall require a submittal of the manufacturer's cut sheets and approval by the Cal Poly Designated Telecommunications Representative.

1.5 IDENTIFICATION

- A. The label shall be 1" white (permanent) polyester/nylon with black ink.
- B. Labels containing a unique cable ID designator shall be placed on both ends of all cables, 6 inches from the termination and/or patch panel.
- C. Subsequent to placing and terminating cables, the Contractor shall place all cable labels as noted above.
- D. If at any time during the job the cable tag becomes illegible or removed for whatever reason, the Contractor shall immediately replace it with a duplicate pre-printed cable label at the Contractor's expense.
- E. All cable labels shall be easily accessible, both physically and visually, upon completion of the job.
- F. Refer to Section 27 05 53 for additional details.

1.6 DEFINITIONS

- A. CMP: Communications Plenum Cable
- B. CMR: Communications Riser Cable
- C. MPP: Multipurpose Plenum Cable
- D. OFNP: Optical Fiber Nonconductive Plenum Cable
- E. OFCP: Optical Fiber Conductive Plenum Cable
- F. LSZR: Low Smoke Zero Halogen Rated Cable
- G. OM1: Defined by ISO 11801 & TIA-492-AAAA, 62.5/125 μm multimode fiber. (old Campus Standard)
- H. OM2: Defined by ISO 11801 & TIA-492-AAAB, 50/125 μm multi-mode fiber.
- I. OM3: Defined by ISO 11801 & TIA-492-AAAC, laser-optimized 50/125 μm multi-mode fiber
- J. OM4: Defined by TIA-492-AAAD, laser-optimized 50/125 μm multi-mode fiber (new Campus Standard)

1.7 WARRANTY

- A. Refer to Section 27 00 00 for general

details. PART 2 - PRODUCTS

2.1 PRODUCT CONSISTENCY

- A. Any given item of equipment or material shall be the product of one

manufacturer throughout the facility. Multiple manufacturers of any one item will not be permitted, unless specifically noted otherwise.

2.2 APPROVED MANUFACTURERS AND MATERIAL

- A. See Section 27 06 00 – Schedules for Communications for approved manufacturers and material to be supplied for this section.

2.3 FIBER OPTIC CABLES - GENERAL

- A. Cable jacket marking: Shall be legible and shall contain the following information:
 - 1. Manufacturer's name and/or trademark
 - 2. Strand count
 - 3. Cable Type
 - 4. UL listing
 - 5. Sequential distance markings, in one-foot increments
- B. All multimode shall be OM4, 50 μ m multimode fiber.
- C. All single-mode shall be zero water peak single mode fiber.

2.4 FIBER OPTIC STATION CABLE (2 STRAND MULTIMODE)

- A. Cable shall be plenum rated, tight buffered, 1.6mm zip cord with strippable jacket and high tensile strength yarn layer.
- B. Jacket color shall be aqua.

2.5 FIBER OPTIC STATION CABLE (2 STRAND SINGLEMODE)

- A. Cable should be plenum rated, tight buffered, 1.6mm zip-cord with strippable jacket and high tensile strength yarn layer.
- B. Jacket color shall be yellow.

2.6 FIBER OPTIC STATION CABLE - FLOOR OUTLET (2 STRAND MULTIMODE)

- A. Non-Armored Jacket shall be plenum and OSP rated.
- B. Cable shall have aramid yarn and zip-cord immediately underneath jacket.
- C. Internal structure shall include water barrier layer and a central dielectric strength member.
- D. Jacket color shall be black.

2.7 FIBER OPTIC STATION CABLE - FLOOR OUTLET (2 STRAND SINGLEMODE)

- A. Non-Armored Jacket shall be plenum and OSP rated.
- B. Cable shall have aramid yarn and zip-cord immediately underneath jacket.

- C. Internal structure shall include water barrier layer and a central dielectric strength member.
- D. Jacket color shall be

black. PART 3- EXECUTION

3.1 GENERAL

- A. Fiber optic station cables shall be used between the MDF, IDF, or SDF and outlets serving user spaces or end user devices.
- B. Location, fiber count and placement detail for all fiber optic cables shall be as shown on the Drawings. Provide 20' slack loops at the MDF, IDF, or SDF end of all fiber optic cables.
- C. Provide 72" of stripped strands fiber wrapped neatly at each fiber cabinet.
- D. Provide 36" of stripped strands fiber wrapped neatly at each fiber outlet.
- E. Ensure all fiber optic cables, as installed, are not subject to strain, and that correct bend radii are maintained at all times.
- F. Fiber optic station cables and copper cables may share conduit with approval of the Cal Poly Designated Telecommunications Representative.
- G. Do not terminate fiber until after the rack locations and elevations of fiber cabinets have been reviewed and approved by the Cal Poly Designated Telecommunications Representative.

3.2 QUANTITIES

- A. Quantities of system elements shown on the Drawings are illustrative only and shall indicate the general configuration of the work. The Contractor shall be responsible for providing the correct quantities of materials to construct a system that meets the intent of these Specifications and the relevant codes.

3.3 INSTALLATION

- A. Optical Fiber Station Cables:
 - 1. Provide support for vertical runs of fiber optic riser cables.
 - 2. Route fiber optic cables over ladder racking.
 - 3. Route fiber optic station cables together as a single bundle, not to be combined with copper or coax cabling.
 - 4. Installation of all fiber optic cables shall require the use of a breakaway swivel rated to the cable manufacturer's written specifications for pull

strength.

5. Follow all manufacturers' specifications for installation.

B. Connector Installation

1. Terminate both ends of each fiber cable with an appropriate fusion spliced factory terminated pigtail type connector. Fiber strands shall be terminated in strict compliance with the manufacturer's printed instructions.
2. Maximum length differential between terminated strands shall be 1". If the length does not meet this requirement the cable shall be re-terminated.
3. Connectors for cables utilizing aramid yarn as a strength member shall integrate the yarn into the termination per manufacturer's written specifications.
4. Connector type for single mode fiber shall be LC.
5. Fiber optic cable shall only be terminated using fusion splices with pig-tails. Field polished direct connections shall not be allowed.

C. Slack Loop

1. Slack loop at faceplate/outlet shall utilize integrated slack loop hardware.
2. Slack loop in MDF, IDF, or SDF shall be mounted on the wall.
3. Slack loop storage location shall be designated by the Cal Poly Designated Telecommunications Representative.

3.4 GROUNDING AND BONDING

- A. None Required

3.5 TESTING

- A. Refer to Specification Section 27 08 23.

3.6 ACCEPTANCE

- A. 100% of the fiber tested shall meet requirements for the whole of the fiber installation to be accepted.
- B. Upon receipt of the Contractor's documentation of cable testing, the Cal Poly Designated Telecommunications Representative will review/observe the installation and randomly request tests of the cables installed.
- C. Once the testing has been completed and the Cal Poly Designated Telecommunications Representative is satisfied that all work is in accordance with the Contract Documents, the representative will notify the Contractor

and/or the Cal Poly Facilities Project Manager in writing or via email.

3.7 RECORD (AS-BUILT) DRAWINGS

- A. The Project Record Drawings shall show the types and locations of all fiber optic cabling and fiber optic termination points. Drawings shall include identifying information as stated on the cable labels.

END OF SECTION

SECTION 27 15 43 – COMMUNICATIONS FACEPLATES AND MODULAR JACKS

PART 1 - GENERAL

1.1 DESCRIPTION

- A. The work covered by this section of the Specifications includes all labor necessary to perform and complete such construction, all materials and equipment incorporated or to be incorporated in such construction and all services, facilities, tools and equipment necessary or used to perform a complete installation of the Telecommunications Systems and Components. The work of this section shall include, but is not limited to, the following:

- 1. Communications faceplates and modular jacks.

1.2 QUALITY ASSURANCE

- A. Refer to Section 27 00 00 for general details.
- B. All contractors and installers working on structured cabling system elements shall hold a current manufacturer's certification for each individual component they install.

1.3 CODES, STANDARDS, AND GUIDELINES

- A. Except as modified by governing codes and by the Contract Documents, comply with the applicable provisions and recommendations in Section 27 00 00.
- B. The University Telecommunication Infrastructure Planning (UTIP) Standards document and Section 27 00 02 - APPENDIX B Labeling-Design-Syntax.

1.4 SUBMITTALS

- A. Refer to Section 27 00 00 for general details.
- B. Shop Drawings:
 - 1. None Required
- C. Submit Manufacturer's Cut Sheets for the following:
 - 1. Any products not specifically listed in the PRODUCTS section shall require a submittal of the manufacturer's cut sheets and approval by the Cal Poly Designated Telecommunications Representative.

1.5 IDENTIFICATION

- A. All faceplates, outlets, and modular jacks shall be labeled per Section 27 00 02 - APPENDIX B Labeling-Design-Syntax. (See Fig. #108 in Section 27 00 02 - APPENDIX B Labeling-Design-Syntax.)
- B. All faceplates that utilize windowed labeling inserts are to be machine generated on paper and inserted behind the windows. See Section 27 00 02 - APPENDIX B Labeling- Design-Syntax.
- C. Wall phone faceplates must be labeled. Use of preprinted self-adhesive labels is acceptable.
- D. Refer to Section 27 05 53 for general details.

1.6 DEFINITIONS

- A. Jack (Modular) - Termination point for telecommunications cabling that transitions from permanently installed station cable to a user end station wire (drop cable).

1.7 WARRANTY

- A. Refer to Section 27 00 00 for general

details. PART 2 - PRODUCTS

2.1 PRODUCT CONSISTENCY

- A. Any given item of equipment or material shall be the product of one manufacturer throughout the facility. Multiple manufacturers of any one item will not be permitted, unless specifically noted otherwise.

2.2 APPROVED MANUFACTURERS AND MATERIAL

- A. See Section 27 06 00 – Schedules for Communications for approved manufacturers and material to be supplied for this section.

2.3 STANDARD WALL FACEPLATE

- A. Faceplates for single gang outlets shall have 4 ports.
- B. All parts are to be white in color unless otherwise required to match electrical.
- C. Approved Manufacturer: AMP, Inc. or Cal Poly ITS Telecomm group approved equal

2.4 Category 6A JACK

- A. Outlets must meet requirements for Category 6A of ANSI/TIA/EIA-568.

2.5 WALL PHONE FACEPLATE W/ JACK

- A. Faceplates shall have a single RJ45 jack wired according to the TIA/EIA Standards.
- B. Attachment of conductors shall be via screw terminals.
- C. Faceplates shall be stainless steel with two studs for hanging a wall phone.

2.6 FLOOR OUTLET BOX

- A. Floor boxes shall accommodate power and electrical with dedicated spaces and conduit entries.
- B. Cover shall be hinged, and have cable egress doors, and be able to fully close with all cable outlets in use.

PART 3- EXECUTION

3.1 GENERAL

- A. Follow all manufacturers' written instructions.
- B. All category modular jacks shall be terminated using the T568A termination scheme specified in ANSI/TIS-568-C.0. (See Fig. #168 in Section 27 00 02 - APPENDIX B Labeling-Design-Syntax)
- C. All faceplates, information outlets, jacks, etc. shall be installed in the correct orientation per Manufacturer's Instructions.

3.2 QUANTITIES

- A. Quantities of system elements shown on the Drawings shall be illustrative only and are meant to indicate the general configuration of the work. The Contractor shall be responsible for providing the correct quantities of materials to construct a system that meets the intent of these Specifications and the relevant codes.

3.3 INSTALLATION

- A. Faceplates
 - 1. Faceplates shall be installed straight and plumb in all directions.
 - 2. Faceplates shall cover the entirety of the outlet box hole in the wall. If, due to overcutting or rough workmanship, the faceplate does not cover the entire hole, the wall shall be appropriately patched and painted for a neat and clean finished appearance.
 - 3. All unused positions in faceplates shall be filled with blanks.
 - 4. All communications outlets/faceplates, with the exception of surface mount boxes, shall be installed over enclosed back boxes.

5. All faceplates shall be fastened to back box with threaded machine screws of appropriate length.
 6. Faceplates shall be installed at appropriate ADA height.
 7. Faceplates shall match the trim color of accompanying electrical outlets
 8. Wall faceplates shall be installed at the same height as accompanying electrical outlets, unless specific heights are noted on the Drawings or it is so stated in the Specifications.
- B. Wall Phone Faceplate
1. Refer to the ADA for requirements concerning wall mount telecommunications devices.
- C. Surface Mount Boxes
1. Surface mount boxes shall only to be used in new construction for outlets above the ceiling or in mechanical/electrical spaces.
 2. Surface mount boxes shall not to be used in user spaces.
 3. Surface mount boxes shall be permanently attached to the building's structure with screws.
 4. Surface mount boxes shall not be installed inside panels used for other services unless those panels are accessible by Cal Poly ITS Telecomm Group personnel.
- D. Floor Boxes
1. Floor boxes shall utilize specified hardware and not require use of any proprietary adapters.
- 3.4 GROUNDING AND BONDING
- A. None Required
- 3.5 TESTING
- A. Modular Jacks shall be tested as an element of the Structured Cabling System.
- 3.6 ACCEPTANCE
- A. Once the testing has been completed and the Cal Poly Designated Telecommunications Representative is satisfied that all work is in accordance with the Contract Documents, the representative will notify the Contractor and/or the Cal Poly Facilities Project Manager in writing or via email.
- 3.7 RECORD (AS-BUILT) DRAWINGS

A. None Required

END OF SECTION

SECTION 27 20 10 – WIRELESS DATA COMMUNICATIONS SYSTEM (WIFI)

PART 1 - GENERAL

1.1 DESCRIPTION

- A. The work covered by this section of the Specifications includes all labor necessary to perform and complete such construction, all materials and equipment incorporated or to be incorporated in such construction and all services, facilities, tools and equipment necessary or used to perform a complete installation of the Telecommunications Systems and Components. The work of this section shall include, but is not limited to, the following:
 - 1. A complete and operable WIFI, Wireless Data Communications System.
- B. All install locations, product configurations, and/or graphics must be approved by the Product Manufacturer and the Cal Poly Designated Telecommunications Representative.

1.2 QUALITY ASSURANCE

- A. Refer to Section 27 00 00 for general details.

1.3 CODES, STANDARDS, AND GUIDELINES

- A. Except as modified by governing codes and by the Contract Documents, comply with the applicable provisions and recommendations in Section 27 00 00.
- B. UL/CSA 60950
- C. FCC Regulations 47CFR part 68
- D. The University Telecommunication Infrastructure Planning (UTIP) Standards document and Section 27 00 02 - APPENDIX B Labeling-Design-Syntax.

1.4 SUBMITTALS

- A. Refer to Section 27 00 00 for general details.
- B. Shop Drawings:
 - 1. All system designs and Drawings shall be provided by the Manufacturer. System specifications shall be provided by the Manufacturer and/or the Cal Poly Designated Telecommunications Representative. All system designs and drawings shall be reviewed and approved by the Cal Poly Designated

Telecommunications Representative prior to purchasing material and/or start of installation.

- C. Submit Manufacturer's Cut Sheets for the following:
 - 1. Any products not specifically listed in the PRODUCTS section shall require a submittal of the manufacturer's cut sheets and approval by the Cal Poly Designated Telecommunications Representative.
- D. Provide Manufacturer's Warranty statement.
- E. Provide all user/installation/programming/service manuals for all installed equipment.

1.5 IDENTIFICATION

- A. All cables, junction boxes, faceplates, Wireless Access Points (WAPs), patch panels and other communications infrastructure shall be labeled per Section 27 00 02 - APPENDIX B Labeling-Design-Syntax.
- B. Refer to Section 27 05 53 for additional details.

1.6 DEFINITIONS

- A. WIFI System shall provide an enterprise level signal to all areas of the specified project. Connected loading requirements (number of users supported at the same time) shall be provided by the Cal Poly Designated Telecommunications Representative.

1.7 WARRANTY

- A. Refer to Section 27 00 00 for general

details. PART 2 - PRODUCTS

2.1 PRODUCT CONSISTENCY

- A. Any given item of equipment or material shall be the product of one manufacturer throughout the facility. Multiple manufacturers of WIFI system equipment shall not be permitted.

2.2 APPROVED MANUFACTURERS AND MATERIAL

- A. See Section 27 06 00 – Schedules for Communications for approved manufacturers and material to be supplied for this section.

2.3 WIFI - WIRELESS DATA SYSTEM

- A. GENERAL
 - 1. Aruba Networks - No Alternate
 - 2. The Contractor shall work with Aruba Networks and bring them to the

project site for the purposes of evaluating the site and developing a system design that delivers to the University a site-wide enterprise level signal that supports the loading characteristics specified by the University.

3. The University shall purchase and have delivered to the Contractor, the Manufacturer specified active components for the Contractor to install.
4. All other construction materials necessary to create the complete specified system shall be the sole responsibility of the Contractor to purchase and install.
5. The wireless access point network design shall be approved by the Cal Poly Designated Telecommunications Representative before any materials are purchased and/or any work begins.
6. The Wireless Access Point System Controller shall be from Aruba Networks and shall be located in a building designated by the Cal Poly Designated Telecommunications Representative. Aruba Products shall be purchased by and provided to the Contractor by the University.

PART 3- EXECUTION

3.1 GENERAL

- A. Installation at minimum shall be as specified by the manufacturer.
- B. Contractor shall provide all conduits, cable, boxes and other passive materials (if not provided by Division 26) to deliver a fully functional system that is constructed within the bounds of all codes, restrictions and Specifications.
- C. Electrical circuits used to provide power to each wireless access point installation shall be full time Power-over-Ethernet (PoE) connections provided by the project via a University installed network switch.
- D. Post Project Cleanup
 1. Remove rubbish, debris, and waste materials and legally dispose of such at an off- campus site.
 2. Restore any landscape, concrete, asphalt or aesthetic elements disturbed during installation.

3.2 QUANTITIES

- A. Quantities of system elements shown on the drawings shall be illustrative only and are meant to indicate the general configuration of the work. The Contractor shall be responsible for providing the correct quantities of materials

to construct a system that meets the intent of these Specifications and the relevant codes.

3.3 INSTALLATION

- A. Do not install wireless access point devices until after the installation locations and cable test results have been approved by the Cal Poly Designated Telecommunications Representative.
- B. All wireless access points (WAPs) shall be installed per manufacturer's installation instructions.
- C. Dual Category 6A Structured Cables shall be provided by the Contractor to each WAP location.
- D. Wireless Access Point (WAP) controllers shall be provided/purchased with project funds but shall be installed and connected to the campus fiber backbone by the Cal Poly ITS Telecomm Group.
- E. The load rating for aftermarket mounting hardware should exceed the weight of the current wireless access point. Same for outdoor mounted access points.
- F. Indoor Wireless access points (WAPs) installed in outdoor locations shall be outdoor rated or installed in an NEMA 4 outdoor rated box approved by Cal Poly Designated Telecommunications Representative

3.4 GROUNDING AND BONDING

- A. All outdoor wireless access points (WAPs) shall be grounded according to the manufacturer's installation instructions.

3.5 TESTING

- A. Testing shall require a heat map proving proper functioning of all WAPs (before the system can be accepted/approved). A random evaluation or demonstration of certain WAPs (up to 10%) shall be provided at no additional cost by the Contractor at the request of and in the presence of a Cal Poly Designated Telecommunications Representative.

3.6 ACCEPTANCE

- A. All installation locations, product configurations, labeling and test data must be approved by the Cal Poly Designated Telecommunications Representative.
- B. Upon receipt of the Contractor's testing documentation, the Cal Poly Designated Telecommunications Representative will review/observe the

installation and randomly request tests of the device as installed.

- C. Once the installation, testing, and repairs (if necessary) have been completed and the final "heat map" has been received and approved by the Cal Poly Designated Telecommunications Representative, the Cal Poly Designated Telecommunications Representative will notify the Contractor and/or the Cal Poly Facilities Project Manager in writing or via email of approval.

3.7 RECORD (AS-BUILT) DRAWINGS

- A. The Project Record Drawings shall show the type and location of each WAP

END OF SECTION

SECTION 27 32 16 – WIRELESS TRANSCEIVERS (RADIO FREQUENCY [RF] COMMUNICATIONS OR CONTROL)

PART 1 - GENERAL

1.1 DESCRIPTION

- A. The work covered by this section of the Specifications includes all labor necessary to perform and complete such construction, all materials and equipment incorporated or to be incorporated in such construction and all services, facilities, tools and equipment necessary or used to perform a complete installation of the Telecommunications Systems and Components. The work of this section shall include, but is not limited to, the following:
1. A complete and operable wireless, RF communications or control system. A partial list of system types would include:
 - a. Two-Way Radios
 - b. Radio Base Stations
 - c. RF System Controls
 - d. Cell Antenna Units (CAU)
 - e. Distributed Antenna Systems (DAS)
 - f. Cell Phone Boosters
 2. All installation locations, products, system configurations, permits, applications and/or licenses must be coordinated with, reviewed, and approved by the Cal Poly Designated Telecommunications Representative.

1.2 QUALITY ASSURANCE

- A. Refer to Section 27 00 00 for general details.

1.3 CODES, STANDARDS, AND GUIDELINES

- A. Except as modified by governing codes and by the Contract Documents, comply with the applicable provisions and recommendations in Section 27 00 00.
- B. Cal Poly University Airwaves Policy -
1. <https://policy.calpoly.edu/cap/1200/cap-1230#cap-1231>

- C. Cal Poly University Two-Way Radio Frequency Coordination Standard -
 - 1. <https://policy.calpoly.edu/cap/1200/cap-1230#cap-1235>
- D. Information Technology Resources Responsible Use Policy -
 - 1. <https://policy.calpoly.edu/cap/1200/cap-1200#cap-1203-1>
- E. FCC Regulations - USC - Title 47 - part 90
- F. The University Telecommunication Infrastructure Planning (UTIP) Standards document and Section 27 00 02 - APPENDIX B Labeling-Design-Syntax.

1.4 SUBMITTALS

- A. Refer to Section 27 00 00 for general details.
- B. Shop Drawings:
 - 1. All system requirements shall be developed by the user. All system designs and specifications shall be developed by the user in coordination with and with the approval of the Cal Poly Designated Telecommunications Representative. Product specifications shall be provided by the Manufacturer and approved by the Cal Poly Designated Telecommunications Representative. All system designs and drawings shall be reviewed and approved by the Cal Poly Designated Telecommunications Representative prior to the purchasing of equipment and/or the start of installation and/or demolition.
- C. Submit Manufacturer's Cut Sheets for the following:
 - 1. Any products not specifically listed in the PRODUCTS section shall require a submittal of the manufacturer's cut sheets and approval by the Cal Poly Designated Telecommunications Representative.
- D. Provide Manufacturer's Warranty statement.
- E. Provide all user/installation/programming/service manuals for all installed/purchased equipment.
- F. Acquire and submit all necessary Cal Poly building permits, authorizations, and approvals for all systems.

1.5 IDENTIFICATION

- A. All RF communications infrastructure and two-way radio equipment shall be FCC licensed as required under the guidance of the Cal Poly ITS Telecomm Group.

1.6 DEFINITIONS

- A. The Two-Way Radio/Transceiver System shall provide an adequate signal level and connectivity to users and/or equipment in all areas within the specified project area. The number of users and types of equipment supported simultaneously shall be specified by the User and approved by the Cal Poly Designated Telecommunications Representative.

1.7 WARRANTY

- A. Refer to Section 27 00 00 for general

details. PART 2 - PRODUCTS

2.1 PRODUCT CONSISTENCY

- A. Any given item of equipment or material shall be the product of one manufacturer throughout the facility/project area. Multiple manufacturers of the same Transceiver/RF system equipment shall not be permitted.

2.2 APPROVED MANUFACTURERS AND MATERIAL

- A. See Section 27 06 00 – Schedules for Communications for approved manufacturers and material to be supplied for this section.

2.3 WIRELESS TRANSCEIVER SYSTEM

A. GENERAL

1. The Contractor shall work with the User and the Cal Poly Designated Telecommunications Representative. The Contractor shall bring them to the project site for the purposes of evaluating the site and developing a system design that delivers a site-wide signal level that supports the User specified loading, coverage and/or control characteristics.
2. All equipment/materials shall be purchased by and/or delivered to the Contractor or the Cal Poly ITS Telecomm Group, whichever group is most appropriate, for installation as specified in the contract documents.

PART 3- EXECUTION

3.1 GENERAL

A.

###

3.2 QUANTITIES

A.

3.3 INSTALLATION

- A. Do not install any transceiver devices until after their installation locations and any pre- installation test results have been reviewed and approved by the Cal Poly Designated Telecommunications Representative.
- B. Contractor shall provide all conduits (unless provided by a different division), cable, boxes and other passive materials to deliver a fully functional system that is constructed within the bounds of all codes, restrictions and specifications.
- C. All wireless transceivers shall be installed per manufacturer's installation instructions.
- D. Post Project Cleanup
 - 1. Remove rubbish, debris, and waste materials and legally dispose of such at an off- campus site.
 - 2. Restore any landscape, concrete, asphalt or aesthetic elements disturbed during installation.

3.4 GROUNDING AND BONDING

- A. RF equipment/system installations performed under this section shall use the most appropriate and conservative of the following two Grounding Standards as determined by the Cal Poly Designated Telecommunications Representative:
 - 1. National Electrical Code
 - 2. Per manufacturers specifications

3.5 TESTING

- A. Testing shall require that the proposed system shall be deemed fully functioning as described in the scope/contract documents by the Cal Poly Designated Telecommunications Representative.

3.6 ACCEPTANCE

- A. All installation locations, product configurations, labeling and testing must be approved by the Cal Poly Designated Telecommunications Representative.
- B. Upon receipt of notice of the Contractor's completion of the installation, the Cal Poly Designated Telecommunications Representative will review/observe the installation and if desired, randomly request tests of the devices as installed.
- C. Once the installation and testing has been completed and the Cal Poly Designated Telecommunications Representative is satisfied that all work is in accordance with the Contract Documents, the Cal Poly Designated Telecommunications Representative will notify the Contractor and/or the Cal Poly Facilities Project Manager in writing or via email of their approval.

3.7 RECORD (AS-BUILT) DRAWINGS

- A. The Project Record Drawings shall show the type and location of each Wireless Transceiver device.

END OF SECTION

SECTION 27 32 26 – EMERGENCY TELEPHONES

PART 1 - GENERAL

1.1 DESCRIPTION

- A. The work covered by this section of the Specifications includes all labor necessary to perform and complete such construction, all materials and equipment incorporated or to be incorporated in such construction and all services, facilities, tools and equipment necessary or used to perform a complete installation of the Telecommunications Systems and Components. The work of this section shall include, but is not limited to, the following:
1. A complete and operable Emergency Telephone System.
 2. All install locations, product configurations, and or graphics must be approved by the Chief of Police of the Cal Poly University Police Department or his/her designee and the Cal Poly Designated Telecommunications Representative.

1.2 QUALITY ASSURANCE

- A. Refer to Section 27 00 00 for general details.

1.3 CODES, STANDARDS, AND GUIDELINES

- A. Except as modified by governing codes and by the Contract Documents, comply with the applicable provisions and recommendations in Section 27 00 00.
- B. UL/CSA 60950
- C. FCC Regulations 47CFR part 68
- D. The University Telecommunication Infrastructure Planning (UTIP) Standards document and Section 27 00 02 - APPENDIX B Labeling-Design-Syntax.

1.4 SUBMITTALS

- A. Refer to Section 27 00 00 for general details.
- B. Shop Drawings:
1. N/A
- C. Submit Manufacturer's Cut Sheets for the following:

1. Any products not specifically listed in the PRODUCTS section shall require a submittal of the manufacturer's cut sheets and approval by the Cal Poly Designated Telecommunications Representative.

D. Provide manufacturer's warranty statement.

E. Provide all user/installation/programming manuals for all installed equipment.

1.5 IDENTIFICATION

A. All cables, protectors, hand-holes, conduit and other communications infrastructure shall be labeled per Section 27 00 02 - APPENDIX B Labeling-Design-Syntax.

B. Refer to Section 27 05 53 for additional details.

1.6 DEFINITIONS

A. N/A

1.7 WARRANTY

A. Refer to Section 27 00 00 for general

details. PART 2 - PRODUCTS

2.1 PRODUCT CONSISTENCY

A. Any given item of equipment or material shall be the product of one manufacturer throughout the facility/project area. Multiple manufacturers of the same Emergency Telephone system equipment shall not be permitted.

2.2 APPROVED MANUFACTURERS AND MATERIAL

A. See Section 27 06 00 – Schedules for Communications for approved manufacturers and material to be supplied for this section.

2.3 HANDS-FREE EMERGENCY PHONE

A. GENERAL

1. The Emergency Phone shall consist of an outdoor-rated, vandal resistant and ADA- compliant hands-free speakerphone communications device with a stainless steel faceplate and metal buttons.

2. The Emergency Phone shall be Talk-A-Phone model ETP-500E, or Cal Poly ITS Telecomm group approved equal, and have one red anodized aluminum tactile button labeled "EMERGENCY" and one 0.375" diameter red light emitting diode (LED) labeled "LIGHT ON INDICATES CALL RECEIVED".

3. The unit shall be programmable from a remote location and have a two number dialing capability, reverting to the second number if the first is busy or does not respond. The unit shall be totally hands-free on both sides after connection is initiated at site or by attendant. The unit shall be phone line powered, requiring no outside power source or battery back-up. DIP switch programming, push to talk devices, and devices requiring external power are not acceptable. The unit shall have a dedicated communication line.

B. CONSTRUCTION

1. Chassis and face plate shall be constructed of stainless steel.
2. Faceplate shall be 12 gauge #4 brushed stainless steel measuring 9.5" W x 11.75" H.
3. Back Box shall be constructed of high impact resistant thermoplastic and measure approximately 6.63" W x 9.75" H x 2.5" D.
4. Unit shall weigh approximately 6 lbs.
5. Signage shall be constructed of cast metal with lettering and Braille raised approximately 3/32" for ADA compliance. Word "EMERGENCY" shall be white (on blue) and the button shall be red.
6. Push button and switch shall be a single assembly rated for 1,000,000 cycles and provide tactile response. Piezo switches not permitted.
7. Speaker and microphone shall be protected by non-ferrous metal screen to provide a barrier against vandalism, rain, snow, and insects.

C. FEATURES

1. Unit shall be capable of operating on standard phone lines or analog PBX extensions.
2. Unit shall dial at approximately 10 tones per second.
3. Output sound level shall be greater than 80 dB at one meter for normal conversation.
4. All programming shall be stored in non-volatile EEPROM memory.
5. Button shall provide tactile feedback.
6. Unit shall be programmable from a remote telephone via keypad entry.
7. Call timer shall be programmable from 1 to 4320 minutes.
8. LED for the hearing impaired shall illuminate to indicate when calling party may speak (when receiving party is silent).

9. Unit shall be programmable with two different telephone numbers of up to 18 digits each including pauses. If first number does not answer or is busy, unit shall automatically call the second number. If that number is busy or does not answer, unit shall call the first number again. Unit shall continue alternating until call is answered or call timer limit is reached.
10. When dialing a secondary number, unit shall be capable of hanging up for a minimum 2.25 seconds to avoid triggering a hook-flash.
11. Unit shall include two auxiliary outputs and one auxiliary input that are opto-isolated from the telephone line to 1,000 volts. Outputs shall be activated, providing a dry contact closure, either automatically when Emergency Phone is activated or manually by guard keypad operation. Input shall allow unit to be activated by any device or switch that provides a contact closure.
12. Incoming and outgoing volume shall be adjustable separately.
13. Unit shall be capable of automatically notifying attendant of location via programmable 6-digit ID.
14. Unit shall be capable of silent monitoring.
15. Unit shall utilize tone dialing.
16. When call is finished, unit shall automatically shut off.
17. Unit shall answer any call placed to it from any other telephone.
18. Two levels of programmable passwords shall be available.
19. Unit shall be varistor lightening suppressed and full wave polarity guarded.
20. Unit shall have parallel tip and ring connected to an RJ-11 connector for quick installation.
21. Unit shall be compatible with Talk-A-Lert[®] diagnostics/base-station package, model ETP-TAL.
22. Unit shall comply with Part 68 of the FCC rules for the United States.

D. ENVIRONMENTAL

1. Speaker: The unit shall be a 3.5" square, RoHS compliant, outdoor rated speaker with an ambient operating temperature range of -67°F (-55°C) to +185°F (+85°C). The speaker shall be capable of withstanding a total immersion for 96 hours and operating without any deterioration of sound quality. The speaker cone shall be constructed of a corrosion resistant material. The speaker shall be constructed of a neodymium magnet and a solid aluminum voice coil and shall be adequately protected from ferrous

and non-ferrous particles via a special sealed design.

2. Microphone: The unit shall be 6mm in diameter, aluminum construction, RoHS compliant, with an IP57 type enclosure to protect from dust and water. The microphone shall have an operating temperature range of -40°F (-40°C) to + 158°F (+70°C). The microphone shall operate within ± 3 db of initial sensitivity, (after 6 hours of conditioning at +25°C) after being placed in a chamber at +40°C and 90 \pm 5% relative humidity for 240 hours.
3. Push Button/Switch: The push button and the switch shall be a single assembly unit with an operating temperature range of -67°F (-55°C) to +185°F (+85°C). The push button and the switch shall be constructed of an aluminum alloy. The enclosure design shall be watertight as per IP68S, 1m rating. The push-button and the switch shall provide tactile feedback.
4. Faceplate (Phone): The faceplate shall be constructed of 12 gauge, 304 grade stainless steel with enhanced corrosion resistance.
5. Keypad: The unit shall have a heavy die cast zinc construction with a marine quality chrome plating on the bezel and buttons. The keypad shall have an operating temperature range of -22° F (- 30°C) to +212°F (+100°C) and 95% humidity (non- condensing). The keypad shall be highly resistant to SO₂, O₃ and oxidation. Silicone pad gasket shall seal out dust and other foreign contaminants.

E. ELECTRICAL

1. Unit shall include six vandal-resistant, oval-head, undercut spanner mounting screws to mount flush into Talk-A-Phone or Cal Poly Designated Telecommunications Representative approved equal flush mounting sleeves, free- standing Tower Mounts, Pedestal Mounts, Surface Mount Accessories and Wall Mounts.

F. MOUNTING

1. Unit shall include six vandal-resistant, oval-head, undercut spanner mounting screws to mount flush into Talk-A-Phone, or Cal Poly Designated Telecommunications Representative approved equal flush mounting sleeves, free- standing Tower Mounts, Pedestal Mounts, Surface Mount Accessories and Wall Mounts

G. OPTIONS

1. Unit shall be available with Intelli-Voice or Cal Poly Designated Telecommunications Representative approved equal. Location Identifier as

model ETP-400V.

- a. Message shall transmit as soon as call is answered.
- b. Message shall be repeatable upon request of operator.
- c. Message duration shall be programmable as 5, 10 or 16 seconds.
- d. Location identifier message and duration shall be programmable from remote location.

2. ETP-AUXIN-KIT shall include a battery and battery holder to power the auxiliary input.

H. COMPLIANCE

1. Unit shall be certified to UL Standard 60950.

I. WARRANTY

1. Equipment shall be warrantied against any defects in material and workmanship, under normal use, for a period of twenty-four months from date of installation. In the event system is found by manufacturer to be defective within the warranty period, manufacturer shall repair and/or replace any defective parts, provided the equipment is returned to manufacturer.

J. MANUFACTURER

1. The Manufacturer shall be Talk-A-Phone Co. (773) 539-1100, 7530 N. Natchez Ave, Niles, Illinois 60714, www.talkaphone.com or Cal Poly Designated Telecommunications Representative approved equal

2.4 RADIUS EMERGENCY PHONE TOWER

A. GENERAL DESCRIPTION

1. The unit shall be a highly vandal-resistant free-standing steel emergency phone tower mount, model ETP-MT/R, with a flashing LED blue light and a lighted faceplate. The tower shall house an ADA-compliant communication device manufactured by Talk-A-Phone Co. or Cal Poly Designated Telecommunications Representative approved equal.
2. The LED blue light shall be continuously lit and shall flash for the duration of a call when emergency button is pressed on the communication device. The communication device shall be capable of activating optional peripheral devices.

B. CONSTRUCTION

1. The unit shall be constructed of 0.25" thick steel and weigh approximately 340 lbs.
2. The tower shall measure 12" W x 10" D x 108" H with a 2" radius on each corner.
3. A multi-coat, rust-inhibitive coating shall be applied to withstand prolonged exposure to harsh environments and be painted safety blue.
4. An internal base plate shall be fully welded within the tower 2" above the tower base. The base plate shall be fabricated of 0.75" A-36 steel. There shall be a 4" diameter center hole for wiring access and four 1" diameter holes for anchor bolt clearance.
5. Tower shall have a wiring access opening measuring 9" H x 6.75" W, located 15" above the base of the tower. The opening shall have a flush cover plate with a wall thickness of 0.25", held in place by two 10-24 countersunk, tamper-resistant spanner screws.
6. An opening shall be cut in the front of the tower for flush-mounting any 400-series or 500-series Talk-A-Phone, or Cal Poly Designated Telecommunications Representative approved equal, emergency phone. The lower edge of the opening shall slope down 30° from rear to front, making the edge difficult to use as a shelf yet convenient as a writing surface.
7. The word "EMERGENCY" shall be emblazoned on all four sides in 3.25" high reflective white letters (custom lettering, sizes and colors must be available).

C. LIGHTING

1. Atop the tower shall be a flashing LED blue light.
2. The blue light shall be a 7.8 watt high efficiency, all-LED construction light. The unit shall retain 70% of its initial lumens after 50,000 hours of operation. The unit shall be lit at all times.
3. The blue light shall have a rating of 209 lumens (peak) and automatically flash 78 times per minute when the emergency phone call is placed and continue flashing until the call has been completed.
4. The polycarbonate refractor/housing shall have a prismatic pattern to increase visibility at greater distances.
5. Refractor housing shall further be enclosed in a clear polycarbonate security enclosure which shall be integral to the tower.
6. The unit shall have a concealed ultra-bright LED assembly to illuminate

the emergency phone faceplate at all times. LEDs shall have a lifetime of 100,000 hours.

D. ELECTRICAL

1. The communication device shall require no external power. It shall be powered by the phone line or a PBX extension.
2. The lighting shall require a 96-132VAC dedicated electrical circuit. Circuits on timers, switches or with other loads shall not be acceptable.
3. All lamps and fixtures shall be UL, ETL, C.S.A. listed. All electrical components shall be hard wired and concealed within the tower. All wiring and electrical fixtures comply with the standards of the National Electrical Code, UL and C.S.A.

E. MOUNTING

1. The tower shall include 24 inch J-bolts for mounting into a 24" x 24" concrete foundation, depth to vary according to local regulations and other site-specific considerations. J-bolts shall protrude approximately 5 inches from the surface of the foundation.
2. An optional mounting kit shall be available for mounting into above the ground locations such as parking decks, where access to a concrete base is available from both above and below.

F. COMPLIANCE

1. Tower shall be certified to UL Standard 60950.

G. WARRANTY

1. Tower shall be warrantied against any defects in material and workmanship, under normal use, for a period of five years from date of installation. In the event system is found by manufacturer to be defective within the warranty period, manufacturer shall repair and/or replace any defective parts, provided the equipment is returned to manufacturer.

H. MANUFACTURER

1. The Manufacturer shall be Talk-A-Phone Co. (773) 539-1100, 7530 N. Natchez Ave, Niles, Illinois 60714-3804, www.talkaphone.com. or a Cal Poly Designated Telecommunications Representative approved equal.

2.5 WALL MOUNT EMERGENCY PHONE STATION

A. GENERAL DESCRIPTION

1. The unit shall be a highly vandal-resistant free-standing steel emergency phone tower mount with a flashing LED blue light and a lighted faceplate. The station shall house an ADA-compliant communication device manufactured by Talk-A-Phone Co. or Cal Poly Designated Telecommunications Representative approved equal.
2. The LED blue light shall be continuously lit and shall flash for the duration of a call when emergency button is pressed on the communication device. The communication device shall be capable of activating optional peripheral devices

B. CONSTRUCTION

1. The unit shall be constructed of 0.105" thick stainless steel and weigh approximately 41 lbs.
2. The unit shall measure 10.5" W x 8.1" D x 31.9" H with a 2" radius on each corner.
3. A multi-coat, rust-inhibitive coating shall be applied to withstand prolonged exposure to harsh environments and be painted safety blue.
4. The unit shall have a wiring access opening for ease of service. The opening shall have a flush cover plate held in place by 10-24 countersunk, tamper-resistant spanner screws.
5. The word "EMERGENCY" shall be emblazoned on the two sides in 2.0" high reflective white letters (custom lettering, sizes and colors must be available).

C. LIGHTING

1. Atop the tower shall be a flashing LED blue light.
2. The blue light shall be a 7.8 watt high efficiency, all-LED construction light. The unit shall retain 70% of its initial lumens after 50,000 hours of operation. The unit shall be lit at all times.
3. The blue light shall have a rating of 209 lumens (peak) and automatically flash 78 times per minute when the emergency phone call is placed and continue flashing until the call has been completed.
4. The polycarbonate refractor/housing shall have a prismatic pattern to increase visibility at greater distances.
5. Refractor housing shall further be enclosed in a clear polycarbonate security enclosure which shall be integral to the unit.
6. The unit shall have a concealed ultra-bright LED assembly to illuminate the

emergency phone faceplate at all times. LEDs shall have a lifetime of 50,000 hours.

D. ELECTRICAL

1. When the emergency phone is used, the communication device shall require no external power. It shall be powered by the phone line or a PBX extension.
2. The light shall require 96-132VAC standard.
3. All lamps and fixtures shall be UL, ETL, C.S.A. listed. All electrical components shall be hard wired and concealed within the unit. All wiring and electrical fixtures comply with the standards of the National Electrical Code, UL and C.S.A.

E. MOUNTING

1. The unit shall be wall mountable with hardware provided.
2. An optional mounting kit shall be available for pole mounting.

F. COMPLIANCE

1. Unit shall be certified to UL Standard 60950.

G. WARRANTY

1. Wall mount unit shall be warrantied against any defects in material and workmanship, under normal use, for a period of two years from date of installation. In the event system is found by manufacturer to be defective within the warranty period, manufacturer shall repair and/or replace any defective parts, provided the equipment is returned to manufacturer.

H. MANUFACTURER

1. The Manufacturer shall be Talk-A-Phone Co. (773) 539-1100, 7530 N. Natchez Ave, Niles, Illinois 60714-3804, www.talkaphone.com. or Cal Poly Designated Telecommunications Representative approved equal.

PART 3- EXECUTION

3.1 GENERAL

- A. Installation at minimum shall be as specified by the manufacturer.
- B. Do not install emergency phones until after their installation location has been approved by the Cal Poly Designated Telecommunications Representative and the University's Chief of Police or designated Police Department representative.
- C. Any surface mount conduits run in support of an emergency phone installation

are to be painted to match the building's finish so as to minimize aesthetic impact. In new construction, surface mount conduit is not allowed.

- D. Electrical circuits used to provide power to emergency phone installations are to be full time, dedicated powered circuits. Electrical circuits that are activated by timer or photo cell or with other loads are not acceptable.
- E. All access panels for wall mounted units shall be completely accessible with at least 3 feet of clearance for maintenance access.
- F. Labeled on the front of the faceplate of the phone. Black writing on white tape.
- G. The unit shall be ADA Compliant.
- H. Installation of the wall-mount unit or pedestal, phone instrument, foundation, and/or mounting hardware shall not violate ADA accessibility requirements.
- I. Post Project Cleanup
 - 1. Remove rubbish, debris, and waste materials and legally dispose of off the Project site.
 - 2. Restore any landscape, concrete, asphalt or aesthetic elements disturbed during installation.

3.2 QUANTITIES

- A. Quantities of system elements shown on the drawings shall be illustrative only and are meant to indicate the general configuration of the work. The Contractor shall be responsible for providing the correct quantities of materials to construct a system that meets the intent of these Specifications and the relevant codes.

3.3 INSTALLATION

A. PEDESTAL INSTALLATION

- 1. Installation is to include a dedicated 1¼" conduit with pull string and wire for Telecom. This conduit is to connect directly to an in-ground hand hole located within 6' of the pedestal. The hand-hole is then to connect to the nearest existing telecommunications infrastructure. Refer to project drawings for specific connection location.
- 2. Cabling serving pedestal phones will require entrance protectors at each end. See section 27 11 13 for details.
- 3. Installation is to include a dedicated ¾" (minimum) conduit for electrical

service. This conduit is to connect directly to an in-ground hand hole located within 6' of the pedestal. The hand-hole is then to connect to the nearest existing electrical infrastructure. Refer to project Drawings for specific connection location.

4. Electrical circuit shall be continuously enclosed in conduit for its entire run until it terminates in an outlet or junction box inside the pedestal.
5. No conduits shall enter the top or side of a pedestal mount phone enclosure. Conduits shall only enter the bottom of the enclosure.
6. The telecom hand-hole shall include a 1/2" x 8' ground rod to bond the pedestal, anchors, conduits and concrete reinforcing metal with a #6 AWG bare copper conductor.
7. Hand-holes shall not be located within the ADA path of travel for the pedestal.
8. Approved Manufacturer: Jensen Precast Product with Lid or Cal Poly Designated Telecommunications Representative approved equal

B. Footings & Mounting

1. Pedestals must be solidly anchored to a foundation with embedded steel 3/4" by 24" j-bolts with 5" of exposed thread.
2. Foundation must be at minimum 24" in diameter and 36" deep.
3. Foundation shall be finished at grade. Unit shall mount one-half inch above the concrete to allow air movement.
4. Foundation construction shall meet all applicable state and local codes.
5. Installation in a pre-poured deck shall utilize a purpose built through bolt kit provided from the manufacturer.
6. Installation shall not rely on the use of drop-in anchors.
7. All steel reinforcing rods in the footing shall be bonded together with a #6 AWG bare copper wire. Leave a 3' stub of grounding wire next to the embedded signal conduit for attachment to planned pedestal.
8. Follow all manufacturers' written recommendations for installation.

C. WALL MOUNT INSTALLATION

1. Installation is to include a dedicated 1 1/4" conduit with pull string and wire for Telecomm connections. This conduit is to lead directly to the nearest existing MDF, IDF, SDF, or cable tray. Refer to project drawings for specific connection location.

2. Installation is to include a dedicated $\frac{3}{4}$ " (minimum) conduit for electrical service. Refer to project drawings for specific connection location.
3. No conduits shall enter the top or side of a wall mount phone enclosure. Conduits shall only enter the back of the enclosure.

3.4 GROUNDING AND BONDING

A. PEDESTAL MOUNT PHONE

1. Pedestal is to be grounded with a #6 AWG copper ground wire. Wire is to be terminated on the provided grounding stud in the tower, and terminated on the ground rod in the accompanying signal hand hole.
2. All entrance protectors located inside the tower shall be bonded to the grounding stud using a #6 AWG copper ground wire.
3. Bond all metal components of the pedestal, including the whip from the steel reinforcing in the footing, to the grounding rod.
4. Follow all manufacturers' written recommendations for installation. Installation shall be in accordance with all applicable codes and ADA standards.

B. WALL MOUNT PHONE

1. Ground the metal enclosure with a #12 AWG copper grounding wire to the provided electrical ground.
2. Follow all manufacturers' written recommendations for installation. Installation shall be in accordance with all applicable codes and ADA standards.

C. Refer to Section 27 05 26 for additional details.

3.5 TESTING

- A. Testing shall require a demonstration of a call from each device proving proper functioning of all accessories and visual notification devices. Each demonstration shall be in the presence of the Cal Poly Designated Telecommunications Representative & designated representative of the Cal Poly Police Department.

3.6 ACCEPTANCE

- A. All install locations, product configurations, and or graphics must be approved by the Chief of Police or his/her designee of the Cal Poly University Police Department and the Cal Poly Designated Telecommunications Representative.
- B. Upon receipt of the Contractor's testing documentation, the Cal Poly Designated

Telecommunications Representative will review/observe the installation and randomly request tests of the device as installed. Once the installation and testing has been completed and the Cal Poly Designated Telecommunications Representative is satisfied that all work is in accordance with the Contract Documents, the Cal Poly Designated Telecommunications Representative will notify the Contractor and/or Cal Poly Facilities Project Manager in writing or via email.

3.7 RECORD (AS-BUILT) DRAWINGS

- A. The Project Record Drawings shall show the types, locations, jack numbers and assigned phone numbers of installed equipment.

END OF SECTION

SECTION 27 40 10 – CABLE ANTENNA TELEVISION SYSTEM (CATV)

PART 1 - GENERAL

1.1 DESCRIPTION

- A. The work covered by this section of the Specifications includes all labor necessary to perform and complete such construction, all materials and equipment incorporated or to be incorporated in such construction and all services, facilities, tools and equipment necessary or used to perform a complete installation of the Telecommunications Systems and Components. The work of this section shall include, but is not limited to, the following:
 - 1. A complete and operable Cable Antenna Television System, CATV.
 - 2. All install locations, products, product configurations, and or labeling must be approved by the Cal Poly Designated Telecommunications Representative.

1.2 QUALITY ASSURANCE

- A. Refer to Section 27 00 00 for general details.

1.3 CODES, STANDARDS, AND GUIDELINES

- A. Except as modified by governing codes and by the Contract Documents, comply with the applicable provisions and recommendations in Section 27 00 00.
- B. UL/CSA 60950
- C. FCC Regulations 47 CFR part 68
- D. The University Telecommunication Infrastructure Planning (UTIP) Standards document and Section 27 00 02 - APPENDIX B Labeling-Design-Syntax.

1.4 SUBMITTALS

- A. Refer to Section 27 00 00 for general details.
- B. Shop Drawings:
 - 1. All system designs, drawings and specifications shall be reviewed for approval by the Cal Poly Designated Telecommunications Representative.
- C. Submit Manufacturer's Cut Sheets for the following:

1. Any products not specifically listed in the PRODUCTS section shall require a submittal of the manufacturer's cut sheets and approval by the Cal Poly Designated Telecommunications Representative.

D. Provide Manufacturer's Warranty statement.

E. Provide all user/installation/programming manuals for all installed equipment.

1.5 IDENTIFICATION

A. All cables, junction boxes, faceplates, taps, splitters, nodes and other CATV infrastructure shall be labeled per the Section 27 00 02 - APPENDIX B Labeling- Design- Syntax.

B. Refer to Section 27 05 53 for additional details.

1.6 DEFINITIONS

A. CATV System shall provide acceptable picture quality and meet FCC level Standards to all areas of the specified project. Connected load estimates (meaning the potential number of users that shall be supported by the system simultaneously) shall be provided by the Cal Poly Designated Telecommunications Representative.

1.7 WARRANTY

A. Refer to Section 27 00 00 for general

details. PART 2 - PRODUCTS

2.1 PRODUCT CONSISTENCY

A. Any given item of equipment or material shall be the product of one manufacturer throughout the facility. Multiple manufacturers of CATV system active equipment shall not be permitted. CATV passive components may vary with respect to Manufacturer with approval of the Cal Poly Designated Telecommunications Representative.

2.2 APPROVED MANUFACTURERS AND MATERIAL

A. See Section 27 06 00 – Schedules for Communications for approved manufacturers and material to be supplied for this section.

2.3 CATV - CABLE ANTENNA TV SYSTEM

A. GENERAL

1. The Contractor shall provide tangible evidence in advance that their proposed installation and testing team members have substantial experience installing and testing similar sized CATV systems. Certification

- by the State of California is acceptable.
2. The Contractor shall provide current state-of-the-art, fiber optic based connectivity between the campus/signal provider "head end" and the new project under design. The University requires the installation of a site-wide system delivering signal levels that support the University specified/provided user loading characteristics.
 3. Installation and System Testing will proceed in the following steps:
 - a. The University shall purchase (with project funds) and have delivered to the Cal Poly Designated Telecommunications Representative, the specified active system components.
 - b. Once all tests of the passive infrastructure have been approved by the Cal Poly Designated Telecommunications Representative, the Cal Poly ITS Telecomm Group shall install all active system components.
 - c. Once all active components have been installed the system shall be returned to the Contractor for picture quality, signal level and leakage testing.
 - d. The results of all tests shall be submitted to the Cal Poly Designated Telecommunications Representative for final review and approval.
 4. All other construction materials necessary to create the complete specified system shall be the sole responsibility of the Contractor to purchase, install and test.
 5. The Contractor shall provide a complete system, designed by an Cal Poly Designated Telecommunications Representative approved RCDD or Engineer. The Contractor shall work in conjunction with and with the approval of the Cal Poly Designated Telecommunications Representative to connect the system to the campus signal provider's "head end" equipment via fiber optic cable.
 6. The Cal Poly Campus CATV "head end" connection is located in Building #2.
 7. The Contractor shall submit all system designs and component selections to the Cal Poly Designated Telecommunications Representative for approval prior to construction and/or installation.
 8. For other passive components of a complete system refer to the appropriate Division 27 Section relating to that component.

PART 3- EXECUTION

3.1 GENERAL

A. INSTALLATION

1. All equipment and materials shall be installed per manufacturer's installation instructions and be in compliance with all codes, regulations and specifications.
2. Contractor shall provide all conduits, cable, boxes and other passive materials to deliver a fully functional CATV system that is constructed within the bounds of all codes, restrictions and specifications.
3. Post Project Cleanup
 - a. Remove rubbish, debris, and waste materials and legally dispose of such at an off-campus site.
 - b. Restore any landscape, concrete, asphalt or aesthetic elements disturbed during installation.

3.2 QUANTITIES

- A. Quantities of system elements shown on the drawings shall be illustrative only and are meant to indicate the general configuration of the work. The Contractor shall be responsible for providing the correct quantities of materials to construct a system that meets the intent of these Specifications and the relevant codes.

3.3 INSTALLATION

- A. Do not install or connect to optical nodes and other active CATV system devices until test data for all fiber optic and coax cabling has been approved by and only if specifically directed to do so by the Cal Poly Designated Telecommunications Representative.
- B. Electrical circuits required to provide power to CATV system active components shall be provided by the contractor as part of the project and shall meet all applicable codes and regulations. Refer to other appropriate Divisions, Specifications, and the University Telecommunication Infrastructure Planning (UTIP) Standards as needed.

- C. The Cal Poly Designated Telecommunications Representative shall be allowed to monitor the installation and have tested any or all of the components of the CATV system.
- D. Acceptable signal level at each faceplate shall be +4 to +7 dbm. Use padding as necessary to provide acceptable signal levels at all faceplates.
- E. Any work or test results that are deemed unacceptable by the Cal Poly Designated Telecommunications Representative shall be reworked and/or retested until the work and/or test data is deemed acceptable.

3.4 GROUNDING AND BONDING

- A. See Division 27 Section 27 05 26

3.5 TESTING

- A. Testing shall require a quality HD picture be viewed on an HD monitor at the faceplate in every room.
- B. A random evaluation or demonstration of certain faceplates shall be performed by the contractor at the request of and in the presence of a Cal Poly Designated Telecommunications Representative.
- C. Required leakage testing shall be provided by the contractor once acceptable signal levels are measured at all faceplates. Any locations not meeting FCC Standards shall be reworked and retested until compliance is reached.

3.6 ACCEPTANCE

- A. All install locations, product configurations, and labeling must be approved in advance by the Cal Poly Designated Telecommunications Representative and conform to Section 27 00 02 - APPENDIX B Labeling-Design-Syntax.
- B. Upon receipt of the Contractor's testing documentation, the Cal Poly Designated Telecommunications Representative will review/observe the installation and randomly request tests of the device as installed. Once the installation and testing has been completed and the Cal Poly Designated Telecommunications Representative is satisfied that all work is in accordance with the Contract Documents, the Cal Poly Designated Telecommunications Representative will notify the Contractor and/or the Cal Poly Facilities Project Manager of acceptance in writing or via email.

3.7 RECORD (AS-BUILT) DRAWINGS

- A. The Project Record Drawings shall show the type and location of each CATV component and connection.

END OF SECTION