

California Polytechnic State University

# Lithium Ion Battery Safety Guidance

*Environmental Health and Safety*

*June 2025*

# Lithium-ion Battery Safety Guidance

## Contents

<u>1.0 PURPOSE .....</u>	<u>2</u>
<u>2.0 BACKGROUND .....</u>	<u>2</u>
<u>3.0 RESPONSIBILITIES .....</u>	<u>3</u>
<u>3.1 Researchers/Students .....</u>	<u>3</u>
<u>3.2 Environmental, Health &amp; Safety (EH&amp;S) Office .....</u>	<u>3</u>
<u>3.3 EHS and Shipping .....</u>	<u>3</u>
<u>4.0 HANDLING AND USE .....</u>	<u>3</u>
<u>4.1 Best Practices for lithium-ion Cell/Battery Use .....</u>	<u>4</u>
<u>4.2 Transporting batteries .....</u>	<u>4</u>
<u>4.3 Charging/Discharging .....</u>	<u>4</u>
<u>4.4 Working Area .....</u>	<u>5</u>
<u>5.0 STORAGE .....</u>	<u>6</u>
<u>5.1 Cells - Batteries - Packs .....</u>	<u>6</u>
<u>5.2 Area .....</u>	<u>6</u>
<u>6.0 SHIPMENT .....</u>	<u>7</u>
<u>7.0 EMERGENCY PROCEDURES .....</u>	<u>7</u>
<u>7.1 Damaged Batteries .....</u>	<u>7</u>
<u>7.2 Overheating, Venting and Leaking Cells .....</u>	<u>9</u>
<u>7.3 Exploded Cell .....</u>	<u>9</u>
<u>7.4 Lithium-ion Battery Fires .....</u>	<u>10</u>
<u>8.0 WASTE MANAGEMENT .....</u>	<u>11</u>
<u>9.0 DEFINITIONS .....</u>	<u>13</u>

## 1.0 PURPOSE

The intent of this guideline is to provide users of lithium-ion (Li-ion) and lithium polymer (LiPo) cells and battery packs with enough information to safely handle them under normal and emergency conditions.

Caution must be taken in Li-ion battery storage, use, management, and disposal due to the potential for fire and injury if these batteries are misused or damaged. There have been several incidents at other universities involving Li-ion and LiPo batteries. These incidents were related to batteries left on chargers for extended times, unattended charging, incompatible chargers, cheap knock-off batteries and shorts from improperly wired or isolated connections.

## 2.0 BACKGROUND

Batteries are classified as primary or secondary. Primary batteries irreversibly transform chemical energy to electrical energy. When the initial supply of reactants is exhausted, energy cannot be readily restored to the battery by electrical means. Alkaline and lithium-metal batteries are examples of primary batteries. Primary lithium batteries are briefly discussed in this guidance but since these batteries contain lithium metal, a water reactive material, the handling recommendations, in an emergency situation, for these batteries are different from Li-ion/LiPo.

Secondary batteries can be recharged; that is, they can have their chemical reactions reversed by supplying electrical energy to (charging) the cell. Secondary batteries age during each cycle so they are not indefinitely rechargeable. Prior to the widespread introduction of Li-ion batteries, lead acid, nickel-cadmium and nickel-metal-hydride were the most common types of secondary batteries.

Li-ion/LiPo batteries have emerged in recent years as the most popular secondary batteries due to advantages that include light weight, higher energy density, low memory effect and longer life span. They provide a compact and powerful energy source for research projects and Remote Controlled (RC) vehicles requiring electrical energy. With this technology, lithium-ions are stored in the anode (negative electrode), and transported during the discharge to the cathode (positive electrode) in a flammable organic electrolyte. The materials used are graphite for the anode and a metal oxide for the cathode.

Li-ion batteries are used in battery packs for portable laptops, power tools and many other devices requiring electrical power. LiPo are commonly seen in applications like RC vehicles where their relatively light weight and high current draw are an advantage. Since both

battery types have similar chemistries, they require similar care in charging and handling to avoid unsafe situations.

## 3.0 RESPONSIBILITIES

### 3.1 Researchers/Students

- Implementation of all applicable provisions of this Procedure.
- Obtain and review the battery manufacturer's Safety Data Sheet (SDS), Technical Specification sheet(s) and/or other documents available.
- Perform hazard analysis to understand the various failure modes and hazards associated with the proposed configuration and type(s) and number of batteries used.
- Ensure that written standard operating procedures (SOPs) for lithium and lithium-ion powered research devices are developed and include methods to safely mitigate possible battery failures that can occur during: assembly, deployment, data acquisition, transportation, storage, and disassembly/disposal. This is especially important when custom battery packs are developed for research that are not designed by the manufacturer.
- Ensure that at the conclusion of testing the battery assemblies are disposed of properly or left in a safe condition for storage.
- Ensure that Li-Ion batteries in housing settings are handled properly (see Appendix C).

### 3.2 Environmental, Health & Safety (EH&S) Office

- Maintain this Guidance.
- Assist in training and communicating safety requirements to personnel.
- Waste management (removal of hazardous waste).
- Assist in the investigation of incidents involving Li-ion/LiPo batteries.
- Incident Response.

### 3.3 EHS and Shipping

- Provides assistance with the shipment of Li-ion/LiPo batteries, including proper packaging and documentation.

## 4.0 HANDLING AND USE

If the cells and batteries are correctly handled, the risk of fire developing from a lithium-ion battery from a reputable manufacturer is very low. Most incidents involving Li-ion batteries find a root cause in the mishandling or unintended abuse of such batteries. Possible causes of lithium-ion battery fires include: over charging or discharging, unbalanced cells, excessive

current discharge, short circuits, physical damage, excessively hot storage and, for multiple cells in a pack, poor electrical connections.

#### 4.1 Best Practices for lithium-ion Cell/Battery Use

- Always purchase batteries from a reputable manufacturer or supplier. Cheap or counterfeit batteries may not undergo the same quality control processes and have a higher likelihood of failing.
- Be sure to read all documentation supplied with your battery.
- Never burn, overheat, disassemble, short-circuit, solder, puncture, crush or otherwise mutilate battery packs or cells.
- Do not put batteries in contact with conductive materials, water, seawater, strong oxidizers and strong acids.
  - Avoid excessively hot and humid conditions, especially when batteries are fully charged. Do not place batteries in direct sunlight, on hot surfaces or in hot locations.
- Always inspect batteries for any signs of damage before use. Never use and promptly dispose of damaged or puffy batteries.
- Lithium-ion batteries assembled to offer higher voltages (over 60 V) may present electrical shock and arc hazards. Therefore adherence to applicable electrical protection standards (terminal protection, shielding, PPE etc.) is required to avoid exposure to electrical hazards.
- Do not reverse the polarity.
- Do not mix different types of batteries or mix new and old ones together (e.g. in a power pack).
- Do not open the battery system or modules unless you have training and permission.
- Do not use the unit without its electronic management system.
- Do not submit to static electricity risks to avoid damages to the Protecting Circuit Board.
- Immediately disconnect the batteries if, during operation or charging, they emit an unusual smell, develop heat, change shape/geometry, or behave abnormally.
- Exercise caution with new products where all safety considerations may not be recognized or that may encourage cheap knock-offs built without adherent to safety standards.

#### 4.2 Transporting batteries

Take precautions to avoid dropping batteries during transport. When you need to transport a battery, protect the battery terminals and uninsulated connections from contact with other objects, use the original packaging or a suitable plastic container.

#### 4.3 Charging/Discharging

The Li-ion battery packs found in portable laptops and similar devices usually, if from a reputable manufacturer, require no user input for charging other than connecting it to the charging cable. They contain a Battery Management System (BMS) in the battery pack that controls the charging process. Be sure to use the manufacturer's AC adapter. Those charging

these batteries still need to follow all manufacturer recommendations and be alert for anomalies like unusually hot batteries.

Batteries used in RC drones and other research projects require a much more conscious effort by users to charge safely and avoid battery damage. Li-ion/LiPo battery users for these applications should incorporate the following recommendations into their charging practices:

- Batteries must only be charged with a charger or charging method designed to safely charge cells or battery packs at the specified parameters. Be absolutely sure that the charger settings are correct for the battery pack being charged – both voltage and current settings.
- Never leave a battery pack unobserved during charging. Always stay in or around the charging location so that you can periodically check for any signs of battery or charger distress. Occasionally check on output levels and balancing effectiveness.
- For series packs (2S and above) always balance charge with a charger capable of monitoring the condition of individual cells to prevent individual cells being overcharged. This charger and the battery should be put on a heat-resistant, nonflammable and nonconductive surface. Fire-safe containers designed for Li-ion batteries are available. Never place them on a car seat, carpet or similar surface.
- Keep all flammable materials away from operating area.
- Do not overcharge (greater than 4.2V for most batteries) or over-discharge (below 3V) batteries.
- Make sure that batteries do not exceed manufacturers' recommended operating temperatures during charging or discharging. Use caution if charging a battery that is still warm from usage, or using a battery that is still warm from charging.
- Never parallel charge since chargers cannot monitor the current of individual cells.
- Best practice is to charge and store batteries in a fire-retardant container like a high quality [Bat Safe](#).
- Do not leave batteries connected to chargers after charging is complete (see [storage](#) section).

#### 4.4 Working Area

- Make sure the working surface is made of a material that is not conductive and non-combustible. If you are working on a conductive material cover the surface with an insulating material.
- The area should be clear of any flammable or combustible materials such as wood tables, carpet and gasoline or other solvent.
- Keep the area free from any sharp objects that may puncture the insulating sleeve on cells.
- Ambient temperature should not exceed 60°C. Best working temperatures are between 15°C and 35°C.

## 5.0 STORAGE

Proper lithium-ion batteries storage is critical for maintaining an optimum battery performance and reducing the risk of fire and/or explosion. Many recent accidents regarding lithium-ion battery fires have been connected to inadequate storage areas or conditions. While lithium-ion spontaneous fires are rare, they need just an internal short circuit to start a series of reactions that may lead to a fire. Other factors that pose a higher risk of fire in a storage area are the type of cell design, chemistry, temperature, state-of-charge, and length of storage period.

The following are some guidelines that if correctly followed will reduce the risk of fire and/or explosion of stored batteries.

### 5.1 Cells - Batteries - Packs

- Every time a battery is not used actively (e.g. for more than 3 days), it should be placed in the storage area to avoid being damaged and becoming unsafe.
- When not using your LiPo/Li-ion battery pack, store it at 60-70% of the pack's rated capacity. Lithium-ion cells should never be stored fully charged, it is suggested to store them with a voltage around 3.8V. Most of the chargers have a "storage mode" that will either charge or discharge the cell to the proper storage voltage. Experts recommend to put the cells in storage mode after every run, this will help the battery to lengthen the usable life span.
- Remove the lithium-ion battery from a device before storing it.
- It is a good practice to use a lithium-ion battery fireproof safety bag or other fireproof container when storing batteries. Always follow manufacturer recommendations on fireproof bags for details on how to correctly use them. Do not buy cheap fireproof bags, they might not be effective.
- Cell terminals must be protected by electrical insulating material.

### 5.2 Area

- Store batteries in a dry and well-ventilated place at room temperature or lower. While batteries can be used safely between -20 and 60 °C (-4 to 140 °F), it is strongly suggested to avoid storing them at a temperature that is close to the upper or lower range.
- Storing batteries in a refrigerator may create internal condensation when the battery is brought to room temperature, and they may become dangerous when operated.
- It is best to have a reserved area ONLY for lithium-ion battery storage. It has to be a cool and dry place, away from heat sources.
- The area should be maintained free from any materials which can catch fire such as wood tables, carpet, or gasoline containers. The ideal surface for storing lithium-ion batteries is concrete, metal, or ceramic or any non-flammable material.
- Batteries can be stored in a metal cabinet such as a chemical-storage cabinet, make sure that batteries are not touching each other.

- Never leave batteries unattended where they can be damaged by someone.
- Have a class ABC or CO<sub>2</sub> fire extinguisher nearby the storage area.

## 6.0 SHIPMENT

Only trained and authorized personnel are allowed to prepare, package, and ship Li-ion batteries. If you are planning to ship Li-ion batteries, with or without equipment, you are required to contact the EHS Office to establish if your product falls under the Dangerous Goods Regulations.

**WARNING: Failure to comply with regulations for shipping hazardous materials can result in significant civil penalties for the shipper of up to \$100,000.00 per violation.**

## 7.0 EMERGENCY PROCEDURES

While all batteries need to be handled with caution, Li-ion/LiPo batteries pose additional safety risks due to their high energy density and flammable electrolyte. When these batteries are poorly manufactured, overcharged or over discharged, incorrectly handled and/or connected, or exposed to excessive mechanical and physical stress, conditions may arise and lead to thermal runaway that in turn may lead to the venting, leaking, explosion and/or fire of the battery cell or pack. All lithium-ion cells users must be aware of and equipped to deal with the emergencies mentioned above.

### 7.1 Damaged Batteries

Battery damage may not always be visible. Events that may damage a Li-ion battery include a fall of 12 inch or greater; crash with a speed of 20mph; puncture by a sharp object; expansion due to overheating. Use of a damaged battery may lead to thermal runaway and subsequent fire.

#### Procedure

- After the impact/accident, if the battery is not hot and/or leaking or smoking, disconnect the battery.
- Remove the battery from the equipment wearing gloves, goggles/safety glasses and lab coat (if available).
- To discharge the battery, move in a well-ventilated area and place the battery in a metal or hard plastic bucket.
- Fill the bucket with a 3% salt water solution.
- After 2 days in the salt water bath, call EHS office to have the battery disposed.
- Check the voltage across the terminals to ensure it has reached 0 V.
- Alternatively, to discharge the battery use a resistor with resistance greater than 10 times the rated internal resistance of the battery.

Commented [RS1]: move to open area

Commented [RS2]: Make sure that the container and salt water solution are readily available per the fire dept.

**Keep in mind that there may be no visible damage, a delayed fire can occur hours or days after the impact/accident.** It is safest to discharge the battery immediately.

## 7.2 Overheating, Venting and Leaking Cells

**Commented [RS3]:** consider adding moving the battery to a less populated area, i.e. outside

When a cell's internal temperature and pressure rise faster than the rate at which they can be dissipated, cell overheating will occur. This may be caused by electrical shorting, rapid discharge, overcharging, manufacturer defects, poor design, or mechanical damage, among many other causes. In series or parallel connected strings of batteries, high connection resistance from a poor electrical connection can lead to overheating. The overheating of a given cell may produce enough heat to cause adjacent cells to overheat in response. If the cell does not return to room temperature it may vent and catch fire or explode. Sounds like "clicks" and "puffs" may indicate a preliminary vent release. Depending on the cell type and manufacturer, the critical temperature ranges around 120-300 °C (250-570 °F) (see manufacturer manual for details on the battery you are using). Follow this emergency procedure if you have overheating, venting or leaking cells.

### Procedure

- If you notice hot cells, disconnect the charger and remove any external short circuit if present.
- If a cell is venting or smoking, evacuate all personnel from the area. The area should be secured to ensure that no unnecessary persons enter.
- If leaking material is present, do not touch it.
- Immediately dial 805-756-2281 or 911 to initiate emergency assistance.
- Do not approach the cell until it reaches room temperature. The cell temperature can be checked using a remote device (i.e. infrared thermometer).
- If a remote device is not available, do not handle the cell for a period of at least 24 hours.
- As soon as the cell reaches room temperature, contact EHS to have the damaged battery removed from the working area as hazardous waste (see section 9.0 waste management).

## 7.3 Exploded Cell

Like a vented cell, an exploded cell is the result of an overheated or mechanically damaged cell. After the explosion of a lithium-ion battery, the room could fill quickly with dense white smoke that could cause severe irritation to the respiratory tract, eyes and skin. All precautions must be taken to limit exposure to these fumes.

### Procedure

- If a cell has exploded, evacuate all personnel from the area. The area should be secured to ensure that no unnecessary personnel enter.
- Immediately dial 805-756-2281 or 911 to initiate emergency assistance.
- If a ventilation system is in place and it is safe to, turn it on, initiate ventilation and continue until the cell is removed from the area and the pungent odor is no longer detectable.
- Contact EHS for assistance in removal of the damaged battery cell as hazardous waste.

## 7.4 Lithium-ion Battery Fires

Li-ion fires may occur as a result of thermal runaway, shorting and other conditions that result in increased temperatures. Once the battery begins to vent flammable vapors, it may quite easily catch fire. Cal Poly personnel are not required to fight fires. Trained fire extinguisher users should attempt to extinguish early stage (incipient) fires only if it is possible to do so safely.

Portable fire extinguishers that can be used include ABC (dry powder), carbon dioxide (CO<sub>2</sub>) and foam (noncombustible). Smothering the fire with sand or sodium bicarbonate may also be effective. After extinguishing the fire water should be used to prevent the affected battery from reigniting and adjacent batteries from overheating.

### **Procedure for a small-scale fire**

A typical example is a small wastebasket fire.

- All personnel from the area should be evacuated.
- Activate the nearest fire alarm pull station.
- If you are trained in fire extinguishers and knowledgeable of the type of battery in use, take the closest CO<sub>2</sub> or ABC extinguisher.
- Make sure you are positioned between the fire and the nearest exit before attempting to extinguish the fire.
- If the use a portable fire extinguisher has little effect on extinguishing the fire, exit immediately. Do not initiate a second attempt.
- If you are able to put out the flames, pour water over the battery to cool it down if this will not create an electrical hazard. You might need 1 to 5 or more liters of water depending on the size of the battery in use.
- By-products of combustion may be toxic when inhaled. In the event of heavy smoke, exit the area immediately. Ensure others have left the area and close doors behind you as you leave.
- EHS will need to assess the situation for cleanup and waste management after the situation is under control.

### **Procedure for a large-scale fire**

In the event of a “larger” fire that has been active for a time, and/or those involving furnishings, interior finishes, and structural building components, evacuate the area.

- Activate the nearest fire alarm pull station. Do not attempt to extinguish the fire by using a portable fire extinguisher.
- Call Campus Police (805-756-2281) from a safe location.

- Plan to be available for Fire Department to provide information. This may include the size, location, and nature of the fire, as well as identifying any hazardous materials, especially in the event of a laboratory fire.
- Detailed information on fighting a lithium-ion battery fire can be found in [Guide 147](#) (Lithium-ion Batteries) of the US DOT Emergency Response Guide.
- EHS will need to assess the situation for cleanup and waste management after the scene is cleared by the Fire Department.

#### First Aid Procedures in Case of Contact with Electrolyte

- While the electrolyte composition will vary depending on the type of the battery cell, the general first aid procedures are the same for an exposure to the electrolyte.
- EYES -- Immediately flush eyes with a direct stream of water for at least 15 minutes while forcibly holding eyelids apart to ensure complete irrigation of all eye and lid tissue.
- Remove contaminated garments.
- SKIN -- Flush with cool water or get under a shower. Remove contaminated garments. Continue to flush for at least 15 minutes. Get medical attention, if necessary.
- INHALATION -- Move to fresh air. Monitor airway breathing; if breathing is difficult, have trained person to administer oxygen. If respiration stops, give proper first aid and/or proper CPR procedures only if CPR-trained. GET MEDICAL ATTENTION IMMEDIATELY.
- For significant exposures to the electrolyte, get immediate medical attention. The applicable SDS should be sent with the patient to the hospital.

## 8.0 WASTE MANAGEMENT

**Commented [RS4]:** waste management with a damaged battery post fire

The California Department of Toxic Substances Control (DTSC) regulates the disposal of batteries, both intact and damaged. Intact Lithium-ion batteries are considered to be Universal Waste (i.e. a subset of the hazardous waste regulations intended to ease the burden of disposal and promote the proper collection, storage, and recycling of certain materials). Damaged Lithium-ion batteries are considered to be Hazardous Waste and must be collected through the EHS Office. The following paragraphs describe the steps needed to comply with the above requirement. It applies to all personnel and researchers that work with batteries.

### 8.1 Disposal

Intact batteries can be collected for recycling in any type of container. Spent battery terminals must be taped and gently placed into a container, which should then be properly labeled for recycling through the Universal Waste Program. Labels should indicate: "Universal waste – Lithium-ion batteries". Do not mix lithium-ion batteries with other types of batteries, such as alkaline, cadmium or other rechargeable spent batteries. A request can be placed online for collection. Complete the [Cal Poly Battery Pick Up form](#) to submit your request.

For damaged batteries and all spills from broken batteries and emergencies, contact the EHS Office for guidance.

*Adapted from MIT Li-Ion Battery Safety Guidance*

## 9.0 DEFINITIONS

**Anode:** the negative electrode typically made with a graphite active material coated onto a metal (usually copper) foil current collector.

**Cathode:** the positive electrode typically made with a metal oxide ( $\text{LiMO}_2$ , where  $M = \text{Ni, Mn, or Al}$ ) or a phosphor-olivine (i.e.,  $\text{LiFePO}_4$ ) coated onto a metal (usually aluminum) foil current collector.

**Electrolyte:** lithium salt (i.e., typically  $\text{LiPF}_6$ ) in a mixture of flammable organic carbonate solvents.

**Cell:** A single battery ([Understanding Battery Specifications](#)).

**Battery Pack:** An assembly of cells that are connected in series and/or parallel ( $xPyS$ ). Each battery pack contains only one type of cell. Connecting cells in parallel increase the pack capacity (ampere hour, Ah) and in series the pack voltage, i.e.,  $y$  times 3.6V (where  $x$  and  $y$  are the number of cells that are connected - see [Appendix B](#) for examples).

**Primary (non-rechargeable) lithium metal cells:** These cells have lithium metal anodes paired with a variety of cathode materials (i.e.,  $\text{MnO}_2$ ,  $\text{CF}_x$ ,  $\text{FeS}_2$ , and  $\text{SOCl}_2$ ) and corresponding nominal voltages (1.5V to 3.5V). Depending on the chemistry and application cells may be available in button and cylindrical form factors. These cells are not rechargeable.

**Secondary (rechargeable) lithium (lithium-ion) cells:** These cells are rechargeable. Depending on the quality, design, and operating window these cells typically can be cycled from hundreds to thousands of cycles. The long cycle life is made possible because the lithium is not present in metallic form. Lithium is intercalated into the electrode active materials (i.e., graphite –  $\text{Li}_{1-x}\text{C}_6$  and lithium metal oxide –  $\text{Li}_{1-x}\text{MO}_2$ ) and moves from the anode to the cathode during discharge and from the cathode to the anode when charging in ionic form. Lithium-ion cells are generally available in cylindrical, prismatic, and pouch form factors.

**Lithium-Ion:** A lithium-ion battery is a type of rechargeable battery in which lithium-ions move from the negative electrode to the positive electrode during discharge and back when charging. (See [appendix A](#))

**Lithium-ion Polymer cells:** Same chemistry as lithium-ion cells but the electrolyte is made as a gel with a polymer host which reduces flammability and prevents leakage of liquid electrolyte from a damaged cell.

**Pouch cell:** The case of the battery is a polymer-aluminum laminate, similar to the material used for potato-chip bags, allowing for light and slender designs.

**C-rating:** A dimensionless way of expressing discharge and charge rates which allows the rate capabilities of different cell designs and chemistries to be compared. For example the

discharge time of a 1Ah cell at different C-rates (0.1C = 10h, 0.5C = 2h, 1C = 1hr, 2C = 30min, 5C = 12min). For a 2Ah cell, the currents would be doubled but the discharge times would be the same. Cells designed for high energy may have continuous discharge rates of 1C to 2C with pulse rates up to 5C. In contrast, high power cells may have continuous rates of 5-10C and pulse rates in the 50-70C range. For a given cell capacity, i.e., 5Ah, the discharge current for a given C-rate would be the capacity value times the C-rate. (See [appendix C](#))

**Battery capacity (Ah or Amp-hour):** The rated Coulombic capacity of the cell. The unit is Amp hour, multiply by 1000 for milliamp hour. The rated capacity is measured at a specified discharge rate, typically 0.2C or 0.3C. The actual capacity obtained in use will depend on temperature, discharge rate, and battery state-of-health (calendar and cycle life, discharge and charge duty cycle and conditions).

**Open-Circuit Voltage (OCV):** The OCV of a cell is present when the current flow is zero and the internal cell state is at equilibrium. For LiMO<sub>2</sub> cathode based cell chemistries the OCV can be correlated with the cell state-of-charge, SOC (100 x Available Capacity/Total Capacity). The cathode chemistry is the primary factor influencing the shape of the curve, voltage range, and temperature dependence. Iron phosphate cathode materials have a “flat” OCV curve versus SOC similar to nickel-cadmium and nickel metal hydride cell types.

The nominal voltage for LiMO<sub>2</sub> cathode cells is typically, 3.6-3.7V. This voltage corresponds to a SOC of 50%. The nominal voltage times the cell capacity generally is a good estimate of the cell energy. The OCV for these cells will generally range from 3V (0% SOC) to 4.2V (100% SOC).

Cobalt oxide based cells may have maximum voltages up to 4.35V.

**Depth-of-Discharge Window (DOD):** DOD is defined as 1-SOC. A cell can be discharged 100%, but practically the maximum SOC may be reduced to 95% to 90% and the min SOC may be limited to 5% to 10% to increase cycle life of battery packs (xPyS). The DOD window may be 80-90%.

**Voltage (V):** During discharge or charge “resistances” within the cell lower or raise the OCV.

$$V_{\text{cell}} = \text{OCV} + I \times \text{DCR} \text{ where DCR= DC resistance of the cell, } I(+ \text{ or } -)$$

During discharge or charge the resistive losses and the chemical energy (endothermic or exothermic) of the cell will determine the temperature rise or fall in the cell.

On discharge, the minimum voltage may be set to 2.75V – 3V. If a cell is severely over-discharged,  $V < 2.5V$ , the copper substrate of the anode may be dissolved. On charging the copper in solution may plate out at the cathode forming a bridge or short back to the anode. If the cell is severely over-discharged (duration or number of times) the resulting short can cause the cell to go into thermal runaway.

The charge voltage should not exceed the maximum rated voltage, typically 4.2V, otherwise overcharging the cell will damage the cell and possibly force the cell into thermal runaway.

Watt-hour (Wh): A measure of energy. The cell will have a rated energy. The actual energy obtained from the cell will depend on the rate of discharge and the temperature of the cell. As rate increases and cell temperature is lowered the amount of energy obtained will decrease.

Battery Management System (BMS): Battery management systems are critical to the safe operation of lithium-ion battery packs. The system protects against: over-charge, over-discharge, and excessive currents and temperatures. The BMS protects the pack from exceeding upper and lower voltage and temperature limits. It will also limit current as a function of temperature. Charging rates are typically reduced below 0°C and not allowed below 20°C. The BMS also estimates pack SOC and available power and communicates this to the device controller. The BMS may also be responsible for providing cell balancing.

If the device controller or human operator does not respond to the BMS request to lower power or stop operation the BMS should disconnect the pack by opening the contactor or relay to the pack or blowing an in-line fuse.

BMS systems can have multiple configurations depending on the application, i.e., central control board with sense (V, T) leads to each cell or central master board with distributed boards with electronics for monitoring multiple cells.

Appendix A

## Lithium Battery Hazard Information



**CAL POLY**  
Fire Safety

Contact Name: \_\_\_\_\_

Contact Number: \_\_\_\_\_

### Emergency Information



CAS No. 7439-93-2



Health Hazards



Flammable materials



Corrosive materials



Explosive materials

**Inhalation:** May irritate the respiratory tract.  
**Skin:** Can cause irritation; wash with soap and water.  
**Eyes:** May cause severe irritation; flush with lukewarm water for at least 15 minutes and seek immediate medical attention.

### Personal Protective Equipment (PPE)



Eye Protection



Protective Gloves



Protective Clothing

- When handling a damaged lithium battery, wear safety glasses to protect your eyes
- Neoprene or natural rubber gloves to prevent skin contact with hazardous materials.

### In Case of Fire Involving Lithium Batteries

**Avoid using water** to extinguish lithium battery fires, except to cool nearby batteries and limit fire spread when multiple units are at risk. In confined areas, use a **Class D extinguisher** (e.g., Lith-X) to prevent hydrogen gas buildup. **Burning batteries emit toxic fumes**, so responders must wear SCBA.

Appendix B

**TAKE CHARGE**  
OF BATTERY SAFETY

-  **Choose Certified Products**  
Choose nationally certified lithium-ion products that are safety tested to ensure they meet essential safety standards.
-  **Handle With Care**  
Stick to the manufacturer's instructions. Use only the original charger, and store batteries in cool, dry places away from hazards. Charge large devices like eBikes outdoors when possible, never overnight or **near exit paths**.
-  **Always stay alert for warning signs**  
**Regularly inspect devices** for bulging, punctures, heat, odors, or strange noises. If white or gray smoke appears, it indicates immediate fire danger; stop use immediately.
-  **Recycle batteries and devices properly**  
**Never throw batteries or battery-powered devices in the trash.** Campus offices can request a battery recycling bucket by submitting a pickup request  
Visit: <https://afd.calpoly.edu/ehs/hazardouswaste>
-  **Get out quickly if there's a fire**  
Recognize signs of battery fire: Unusual sounds, smoke, or heat, and evacuate immediately following your fire escape plan. **Call 9-1-1 as soon as you're safe.**
-  **Educate others about battery safety**  
Share what you've learned about lithium-ion battery safety with others to help prevent accidents and promote safe use campus-wide!

Appendix C

Appendix D

Image courtesy of Boston Power

# Lithium-ion cell chemistry

## "Rocking Chair Battery" "Intercalation"

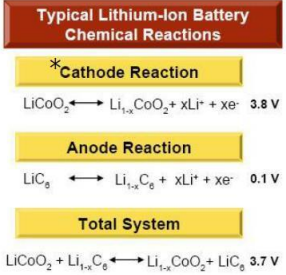
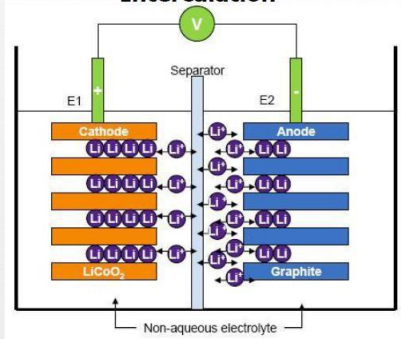

\*  $\text{LiMO}_2$  where M= Co, Mn, Ni, Al, or various combinations

A stable **solid electrolyte interface (SEI) layer** is a critical enabler of Li-ion technology

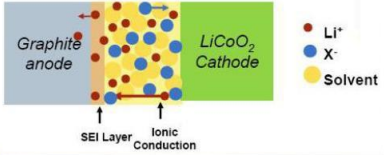

**Appendix E**

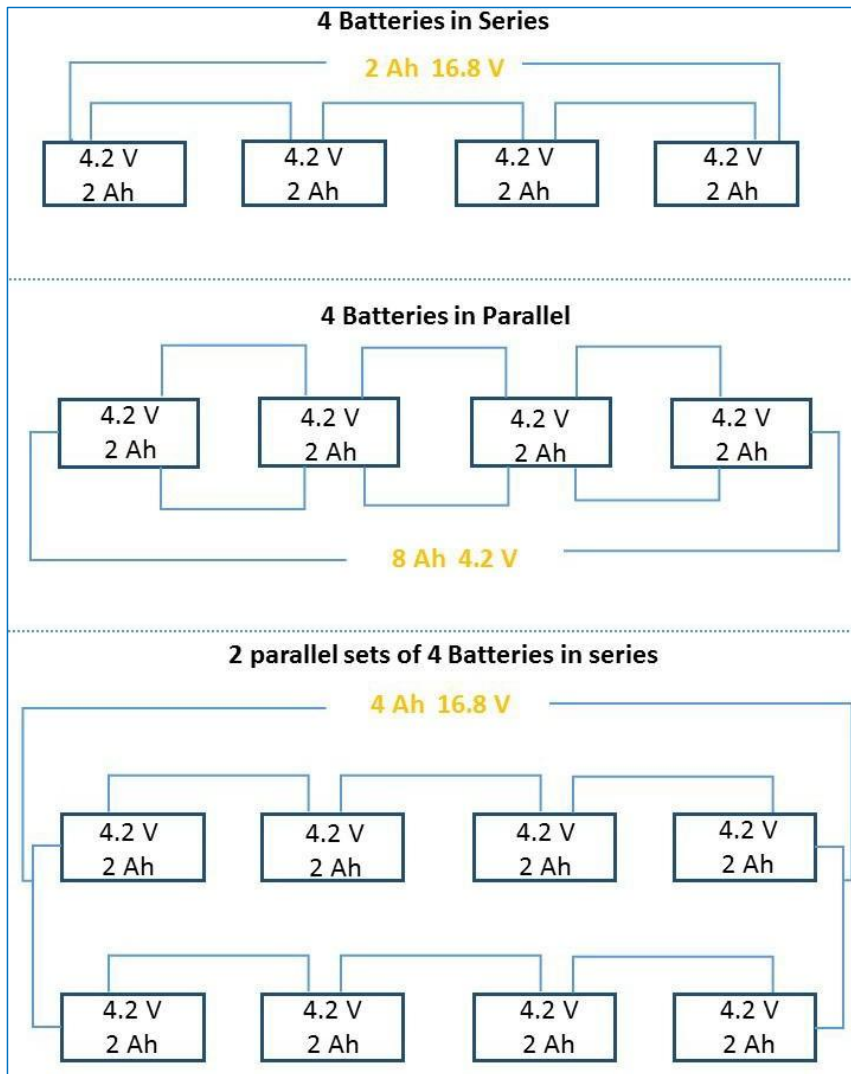

## **Appendix F**

### **LiPo/Li-ion Battery C-Rating Explained**

C Rating is the tested value at which a battery can be continuously charged or discharged without damage. The following formula allows calculating the maximum constant discharge current you can draw from the Li-ion/LiPo pack safely without harming the battery pack.

$$\text{Max current draw (A)} = \text{Capacity (Ah)} \times \text{C - rating}$$

For example, if you have a 1000mAh (=1Ah), 20C LiPo pack (3S), your safe max current draw would be

$$1\text{Ah} \cdot 20\text{C} = 20\text{A}$$

For this particular example, it is possible to draw more current than the 20A, but it is not recommended as it might damage the battery.

### **Cell Energy Example**

The formula to calculate the cell energy is

$$\text{Energy (Wh)} = \text{Capacity(Ah)} \cdot \text{Voltage(V)}$$

Where Q is the capacity of the battery (Ah) and V is the nominal voltage of the battery (V).



The energy for the battery in the picture is

$$E = 5.2 \text{ Ah} \cdot 3.7\text{V} = 19.24 \text{ Wh}$$