

Precast concrete Wheel Stop,  
~~Black with reflective strip or Federal Yellow~~  
 paint as required by the University

Anchoring Hole  
 (2) min. for 48" length,  
 (3) min. for 72" length

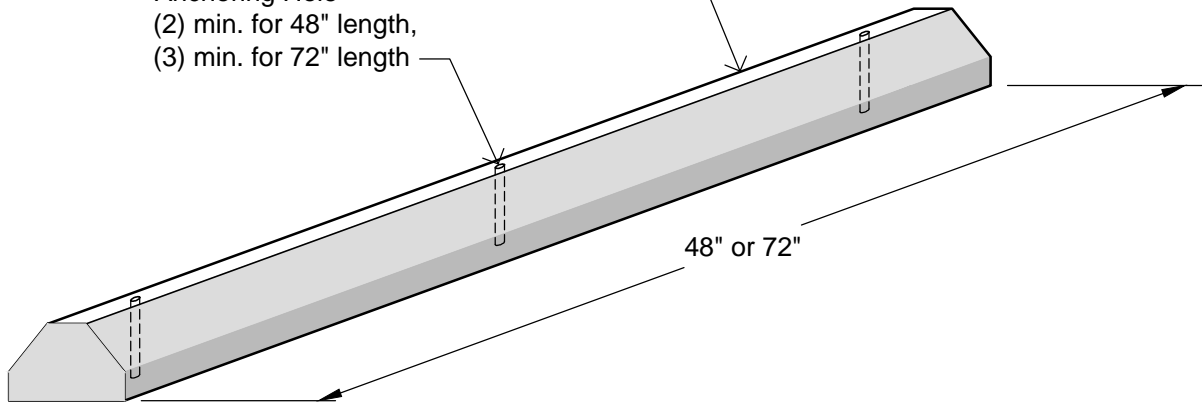

#4 deformed steel  
 reinforcing bar

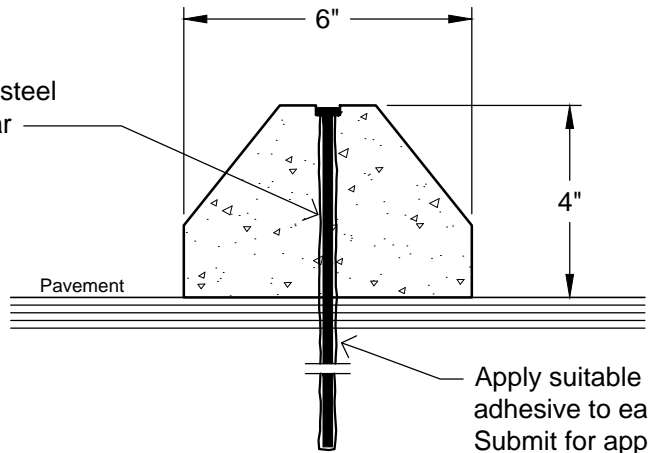

**SECTION VIEW**

**GENERAL NOTES:**

- A. Wheel stop shall be installed at location where wheeled vehicles may roll into pedestrian, structures, or hazardous area. Wheel stop location shall not create a barrier for pedestrians.
- B. Wheel stop shall be securely attached onto at-grade concrete and at-grade asphalt pavement with #4 deformed steel reinforcing bars embedded in holes cast into wheel stops. At concrete pavement, drill holes in pavement for dowels. At parking structure slabs, do not drill, epoxy to slab.

SCALE: N.T.S.

STANDARD CURRENT AS OF: 10/21/2019

APPROVED BY: XX

NOTES:



CAL POLY

**WHEEL STOP**

2260